



8339 N.W 54th Street, Miami, FL 33166
 P. (305) 602 0283 | F. (305) 602 0285
www.saenzperformance.com

Company :
 Contact :
 Phone : FAX :
 EMAIL :

Quantity required : Good Thru :

(*) If we have manufactured rods for you in the past, please

I.M Code #: [] . If making changes, please fill in changes only.

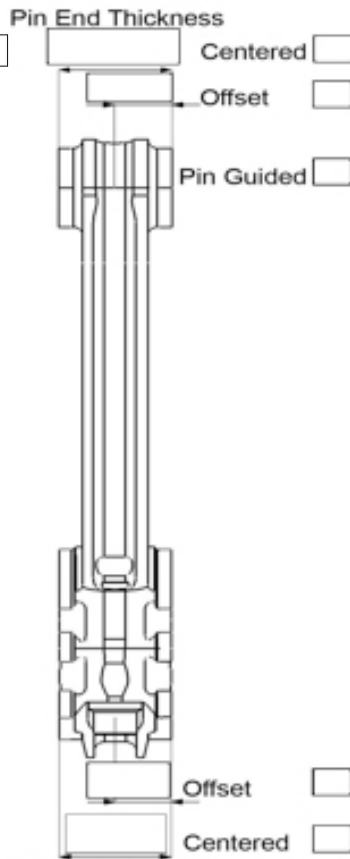
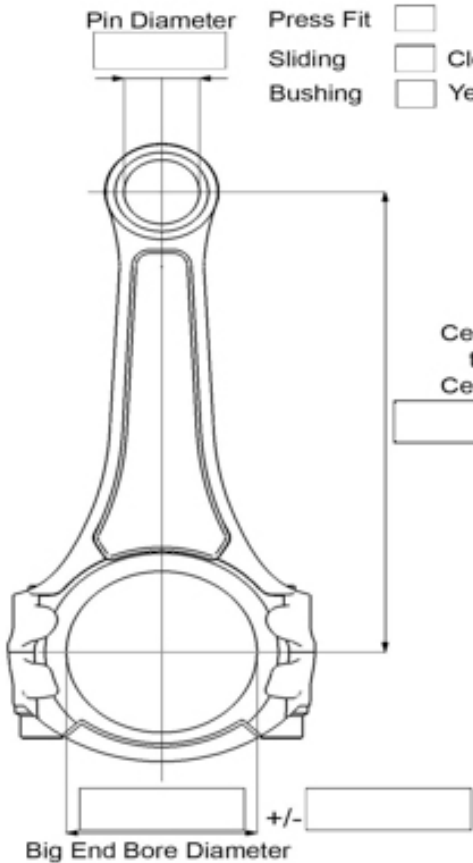

Car Type :
 Engine :
 No. of Cyl. :
 Cyl. Bore :
 Max RPM :
 Stroke :
 Rod Bolts :
 Max. HP :
 Piston Weight :
 Target Weight :

Beam Type :
 I Type
 H Type
 No Preference

Rod Material :
 4340
 300M
 TI

Application :
 Street
 Race
 Endurance
 Turbo
 Nitro

Bearing :

Engine :

Notes :

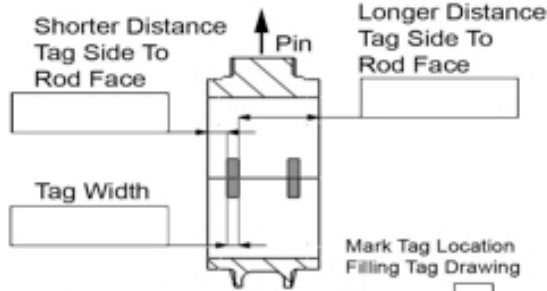

Bearing Centered in Big End
 Bearing Not Centered in Big End Offset :

Mark rod type required

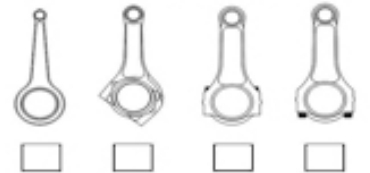

CLEARANCE : Please indicate with a circle if any external part of the rod need care in design in order to avoid touching any other engine component. Feel free to suggest any dimension.

This spec sheet attempts to tailor your prospective rod to fit your project needs.
 If you have any problem filling out spec. please call **SAENZ PERFORMANCE** at (305) 602 0283.