

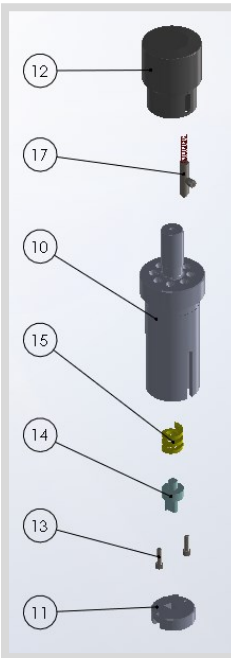

CUSTOMER INFORMATIONS

Name : _____ Telephone n. : _____
 Machine Model : _____ Fax : _____
 Material Type : _____ Email : _____
 Material Thickness : _____ Address : _____

LANCE UP PUNCH	
⇒	Adjustable lenght
⇒	Replaceable insert
12	HEAD
17	ADJUSTING LEVER
10	PUNCH HOLDER
15	SPRING
14	EJECTOR
13	SCREW
11	STRIPPER



LANCE UP DIE	
⇒	Die with stripper and springs
⇒	Replaceable insert
2	STRIPPER PLATE
3	LOWER PUNCH
6	SCREW
7	SPRING
5	SCREW
9	PIN
1	DIE HOLDER
8	PIN

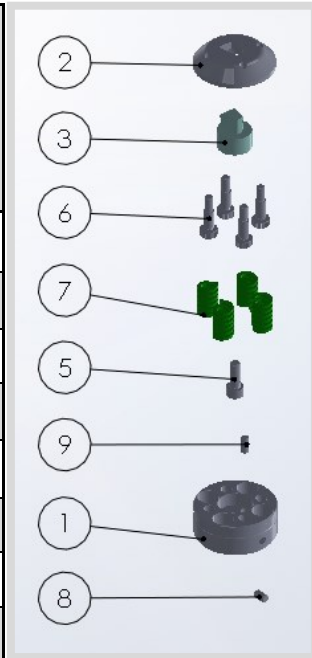

Notes and drafts. Please specify here the distance of any close deformation.

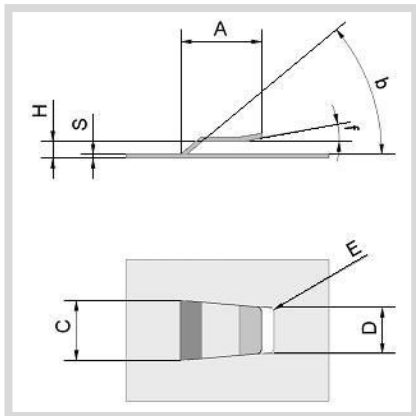

ORDERING SPECIFICATIONS

Order _____ Offer _____
 Item required: _____

 Number of previous order: _____

CUSTOM DIMENSIONS (mm)

H= _____ C= _____
 A= _____ D= _____
 S= _____ * E= _____
 b= _____ TICN coating: YES / NO
 f= _____