

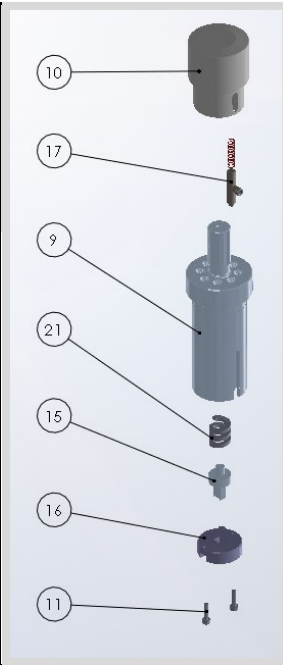

CUSTOMER INFORMATIONS

Name : _____ Telephone n. : _____
 Machine Model : _____ Fax : _____
 Material Type : _____ Email : _____
 Material Thickness : _____ Address : _____

BRIDGE PUNCH	
⇒	Adjustable lenght
⇒	Replaceable insert
10	HEAD
17	ADJUSTING LEVER
9	PUNCH HOLDER
21	SPRING
15	EJECTOR
16	UPPER DIE
11	SCREW



BRIDGE DIE	
⇒	Die with stripper and springs
⇒	Replaceable insert
12	STRIPPER PLATE
13	LOWER PUNCH
1	SCREW
20	SPRING
5	SCREW
6	PIN
8	DIE HOLDER
7	PIN

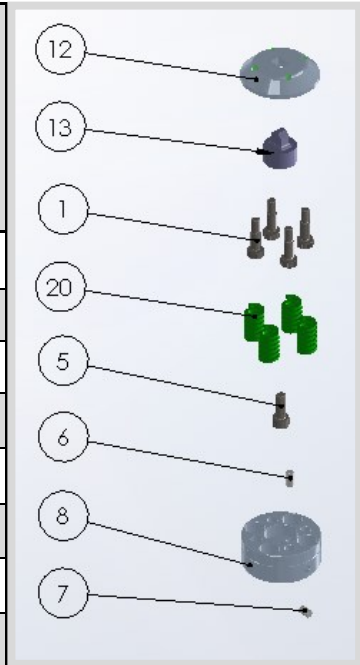

Notes and drafts. Please specify here the distance of any close deformation.

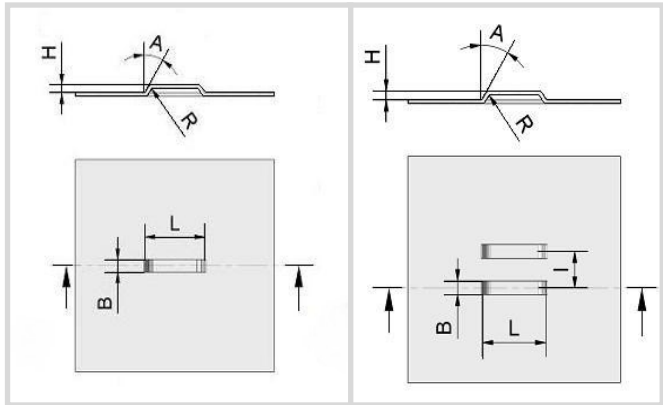

ORDERING SPECIFICATIONS

Order _____ Offer _____
 Item required: _____

 Number of previous order: _____

CUSTOM DIMENSIONS (mm)

H= _____ R= _____
 A= _____ l= _____ (double bridge)
 B= _____ * TYPE: DOUBLE / SINGLE
 L= _____ TICN Coating: YES / NO
 * min = 1.5 x thickness (MS)
 min = 2 x thickness (SS)