

CUSTOMER INFORMATIONS

Name : _____ Telephone n. : _____
 Machine Model : _____ Fax : _____
 Material Type : _____ Email : _____
 Material Thickness : _____ Address : _____

EMBOSS PUNCH	
⇒ Adjustable lenght	
⇒ Replaceable insert	
10	PUNCH HOLDER
11	UPPER DIE
12	HEAD
13	SCREW
15	ADJUSTING LEVER

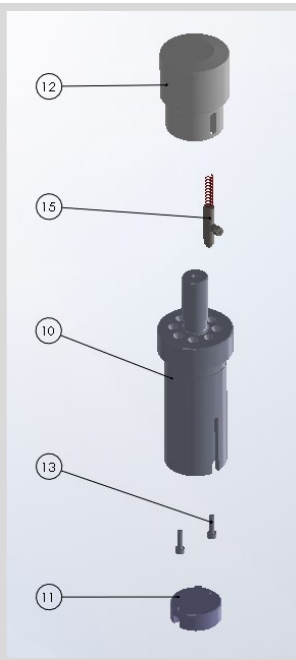

EMBOSS DIE	
⇒ Die with stripper and springs	
⇒ Replaceable insert	
1	DIE HOLDER
2	STRIPPER PLATE
3	PUNCH
5	SCREW
6	SCREW
7	SPRING
8	PIN
9	PIN

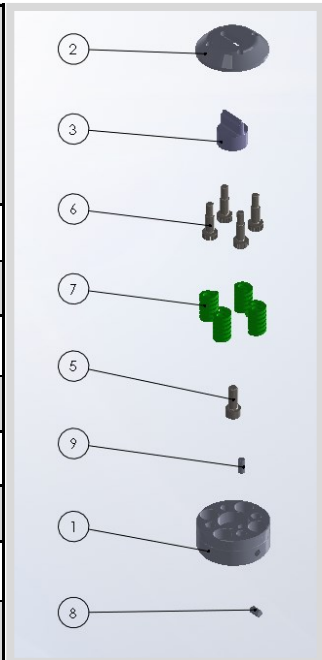

Notes and drafts. Please specify here the distance of any close deformation.

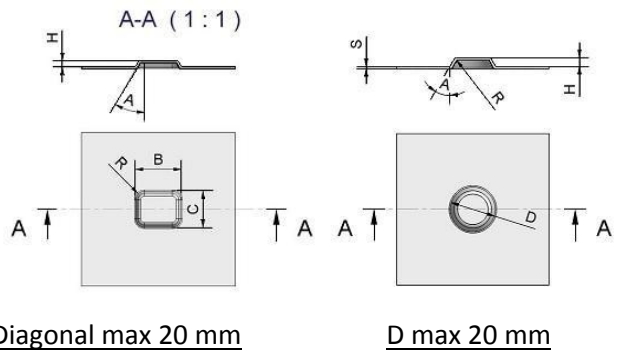

ORDERING SPECIFICATIONS

Order _____ Offer _____
 Item required: _____

 Number of previous order: _____

CUSTOM DIMENSIONS (mm)

ROUND/SHAPE : _____
 H= _____
 A= _____ *
 S= _____
 R= _____
 B/C= _____
 D= _____
 TICN coating: YES / NO
 * = not strictly required