

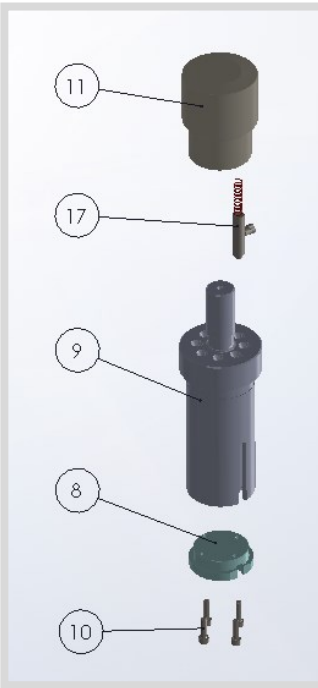

CUSTOMER INFORMATIONS

Name : _____ Telephone n. : _____
 Machine Model : _____ Fax : _____
 Material Type : _____ Email : _____
 Material Thickness : _____ Address : _____

COUNTERSINK PUNCH	
⇒	Adjustable lenght
⇒	Replaceable insert
11	HEAD
17	ADJUSTING LEVER
9	PUNCH HOLDER
8	DIE
10	SCREW



COUNTERSINK DIE	
⇒	Die with stripper and springs
⇒	Replaceable insert
2	STRIPPER PLATE
3	LOWER PUNCH
6	SCREW
7	SPRING
5	SCREW
13	PIN
1	DIE HOLDER
12	PIN

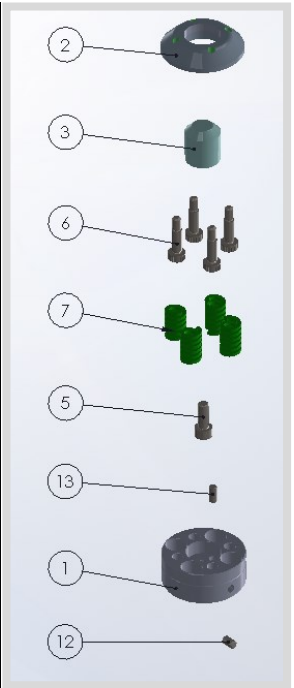

Notes and drafts. Please specify here the distance of any close deformation.

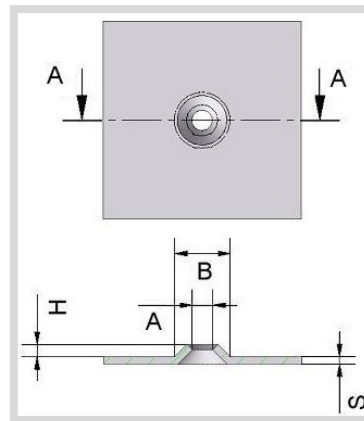

ORDERING SPECIFICATIONS

Order _____ Offer _____
 Item required: _____

 Number of previous order: _____

CUSTOM DIMENSIONS (mm)

A = _____
 B = _____
 H = _____
 S = _____

Order with pre-pierce tool : _____ YES / NO
 Direction: _____ Up