

CUSTOMER INFORMATIONS

Name : _____ Telephone n. : _____
 Machine Model : _____ Fax : _____
 Material Type : _____ Email : _____
 Material Thickness : _____ Address : _____

| CONTINUOUS LOUVER PUNCH | |
|-------------------------|--------------------|
| ⇒ | Adjustable lenght |
| ⇒ | Replaceable insert |
| 10 | UPPER BODY |
| 11 | LOUVER DIE |
| 12 | HEAD |
| 16 | ADJUSTING LEVER |
| 13 | SCREW |

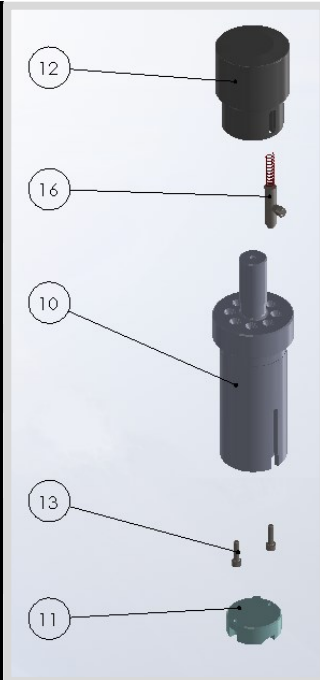

| CONTINUOUS LOUVER DIE | |
|-----------------------|-------------------------------|
| ⇒ | Die with stripper and springs |
| ⇒ | Replaceable insert |
| 1 | DIE HOLDER |
| 2 | STRIPPER PLATE |
| 3 | PUNCH |
| 5 | SCREW |
| 6 | SCREW |
| 7 | SPRING |
| 8 | PIN |
| 9 | PIN |

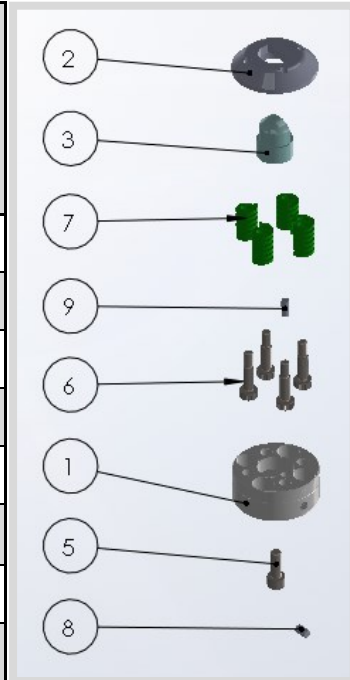

Notes and drafts. Please specify here the distance of any close deformation.

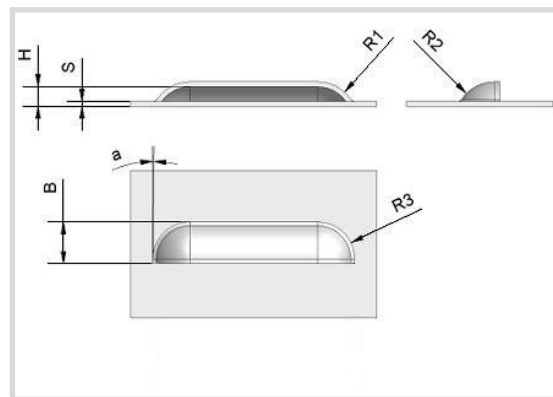

ORDERING SPECIFICATIONS

Order _____ Offer _____
 Item required: _____

 Number of previous order: _____

CUSTOM DIMENSIONS (mm)

B = _____
 a = _____ * R3 = _____ *
 H = _____ (Standard dimension: 5)
 S = _____ R1 = _____ * R2 = _____ *

Min.distance between louvers _____
 x= _____ y= _____
 TICN coating: _____ YES
 * = not strictly required