

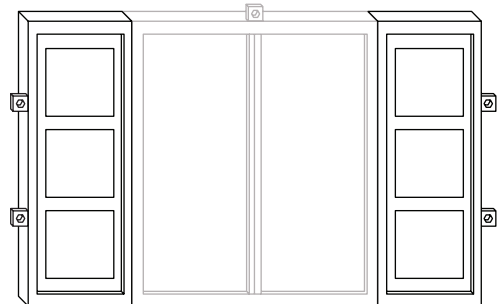

## PRODUCT GUIDE

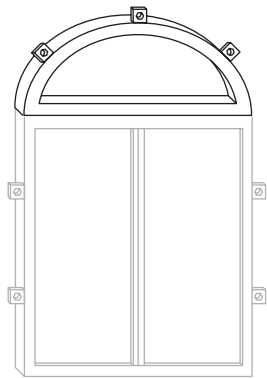
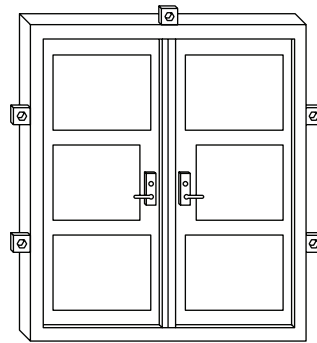
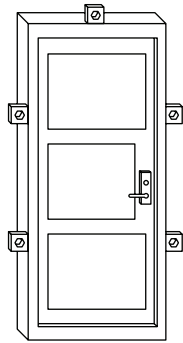

**⚠ VERY HEAVY**

**⚠ Requires 2 or more able bodies**

**⚠ Following instructions must be followed for warranty to be valid**

**⚠ Rough opening must be 1" to 2" wider and 1/2" to 1" taller minimum**

**⚠ Protect product at all times**

- NEVER leave uncovered
- NEVER allow the product or shipping package to get wet
- ATTENTION remove nails from crate prior to removing product to avoid scratching the product

**⚠ Store product correctly WARNING VERY IMPORTANT!**

- ALWAYS remove and discard shipping packaging when received
- ALWAYS store in a DRY and SAFE place using fabric padding
- NEVER use shipping packages to store the product
- ALWAYS wipe ANY moisture off product as moisture will cause product finish to bubble and rust

**⚠ Hardware specifications**

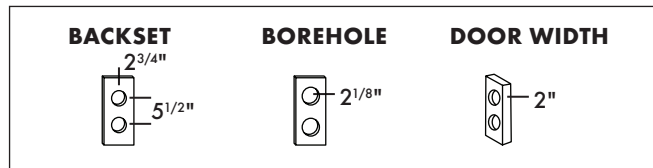

**⚠ Waterproofing preparations required before installation**

- ALWAYS follow waterproof manufacturers instructions and guidelines

**⚠ MUY PESADO**

**⚠ Requiere 2 o más cuerpos capaces**

**⚠ Deben seguirse las siguientes instrucciones para que la garantía sea válida**

**⚠ La abertura debe ser 1" a 2" de ancho y de 1/2" a 1" de altura como mínimo**

**⚠ Proteja el producto en todo momento**

- NUNCA deje descubierto
- NUNCA permita que el producto o el paquete de envío se mojen
- ATENCIÓN retire las uñas de la caja antes de retirar el producto para evitar rayar el producto

**⚠ Almacene el producto correctamente ADVERTENCIA MUY IMPORTANTE!**

- SIEMPRE retire y deseche el embalaje de envío cuando lo reciba
- SIEMPRE almacene en un lugar SECO y SEGURO utilizando acolchado de tela
- NUNCA use paquetes de envío para almacenar el producto
- SIEMPRE limpie CUALQUIER humedad del producto ya que la humedad hará que el acabado del producto burbujee y se oxida

**⚠ Especificaciones de equipos**

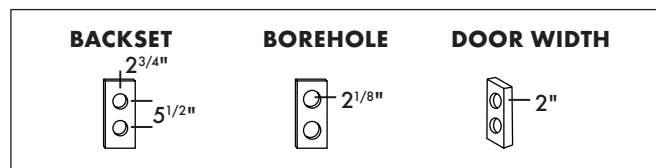

**⚠ Preparaciones de impermeabilización requeridas antes de la instalación**

- SIEMPRE siga las instrucciones y pautas de los fabricantes de impermeables

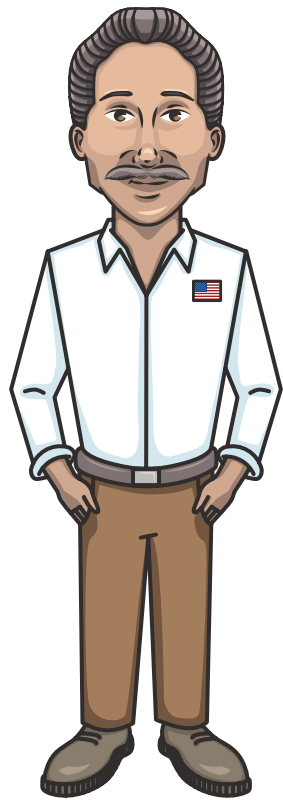

Hello! Below are some tools & tips you will need to successfully install Pinky's doors. Good luck!

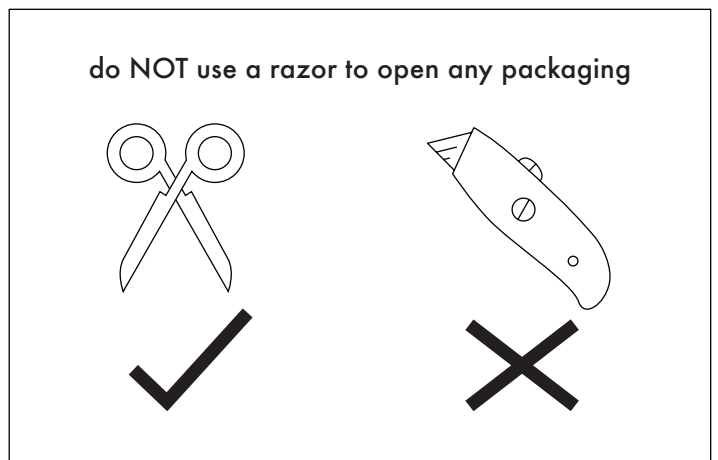
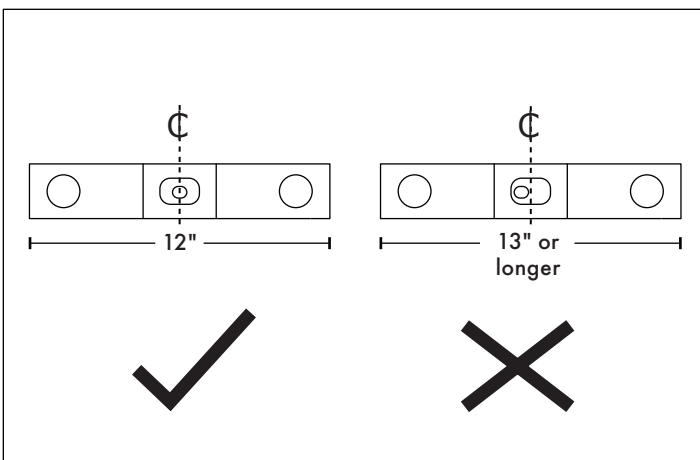
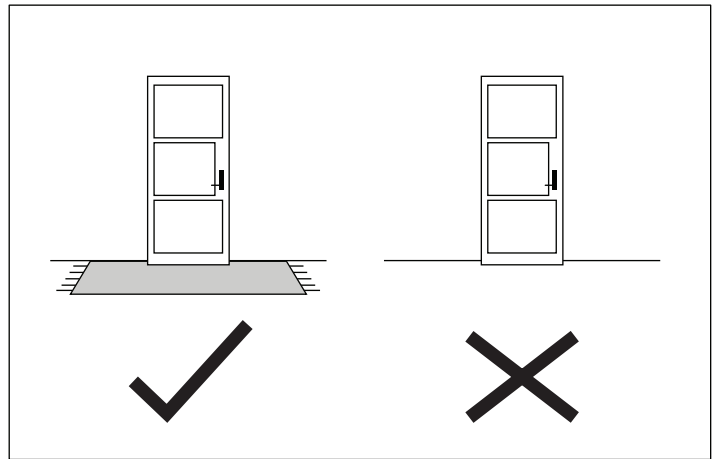
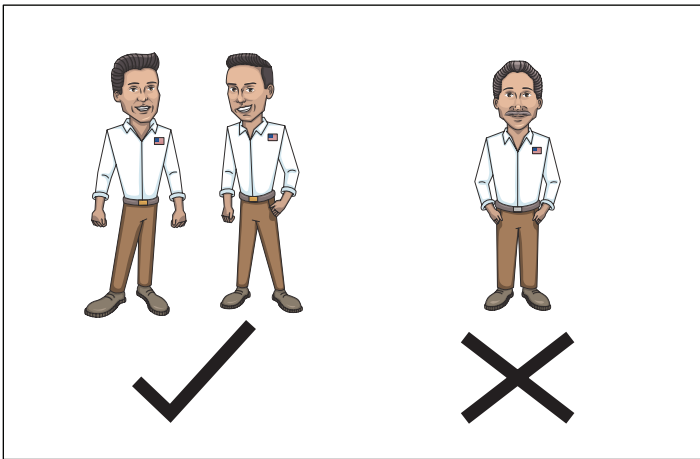
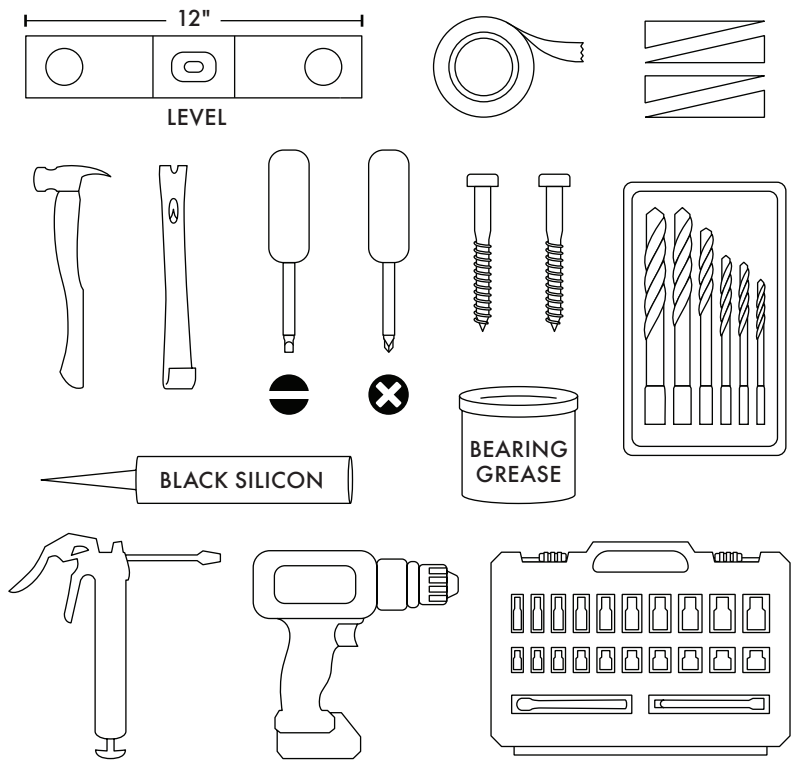

## MATCH DOORS WITH FRAMES

**Avoid Damage to Finish on Door and Frame**

**Doors are manufactured as one unit with their frames. If you have received multiple sets of the same size door, match the serial number of the frame with the door(s).**

Refer to the CAD drawing that is on the packaging of the doors & frame (see below illustration). Ensure you match the entire serial # & do not mix serial numbers between units. Hanging doors on the incorrectly matched frame can result in alignment issues.

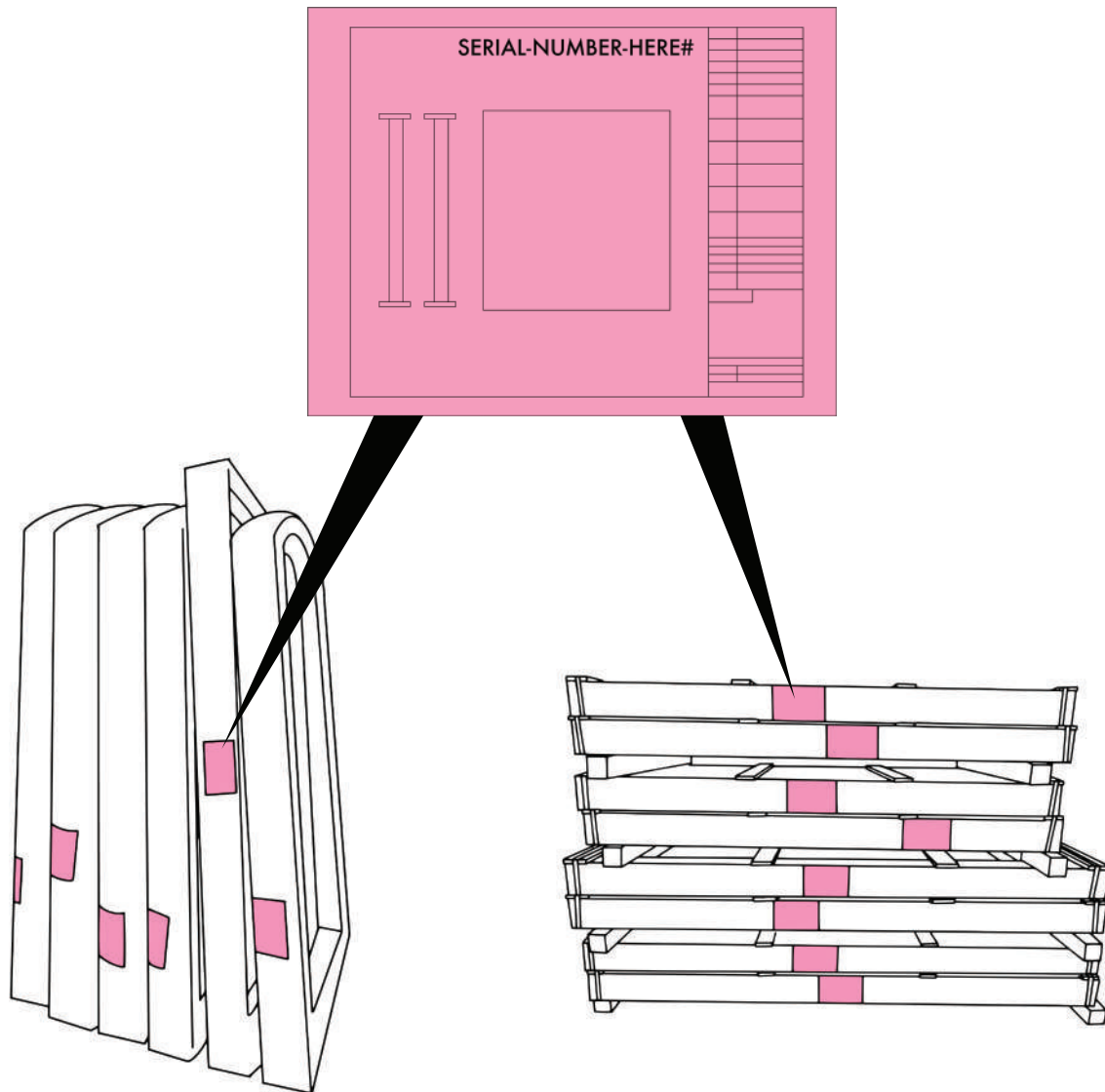

# Opening Wood Box

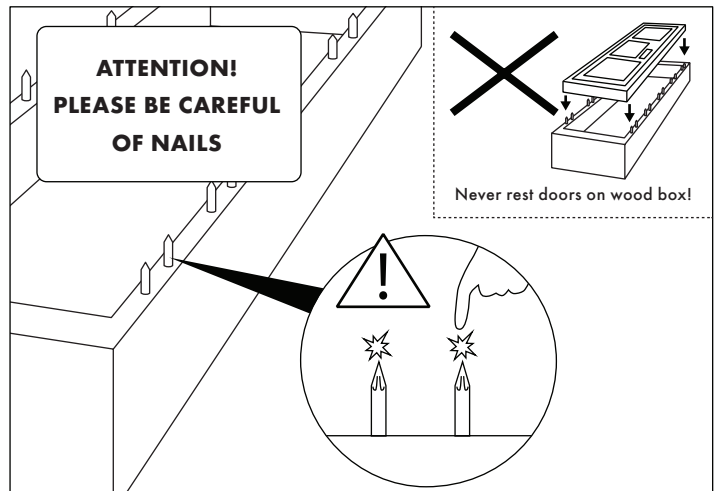
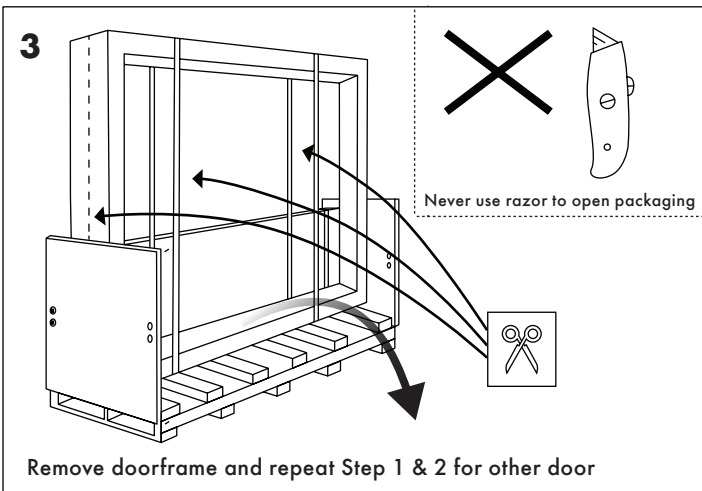
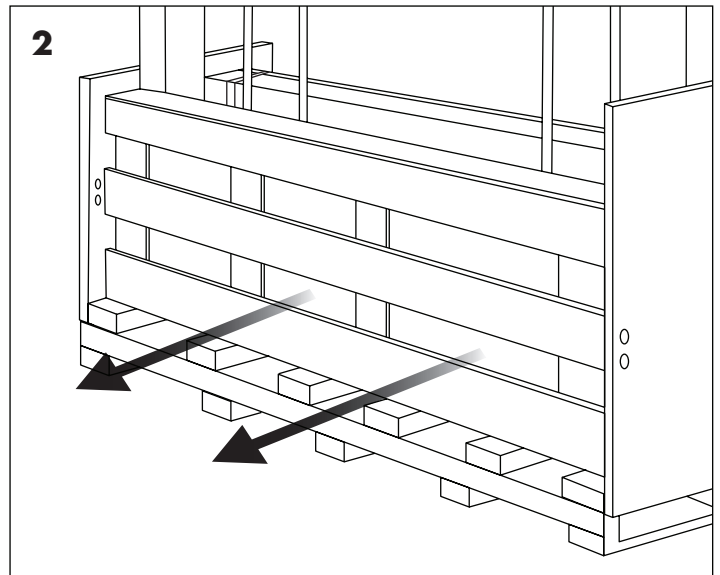
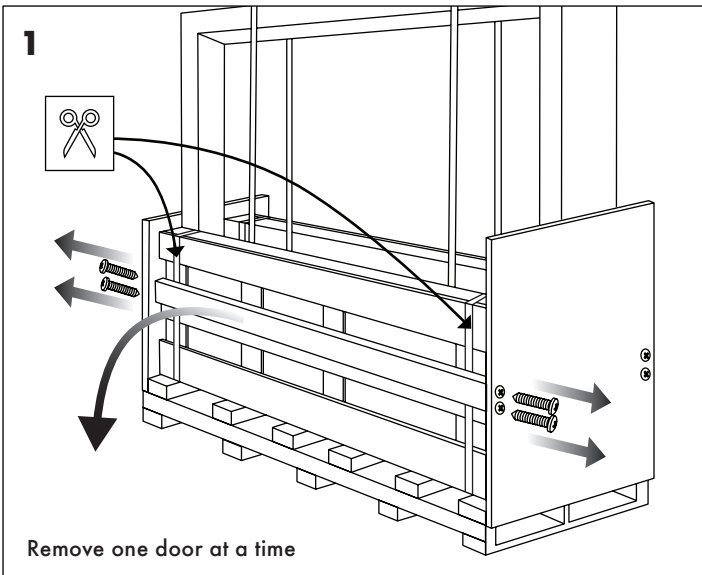
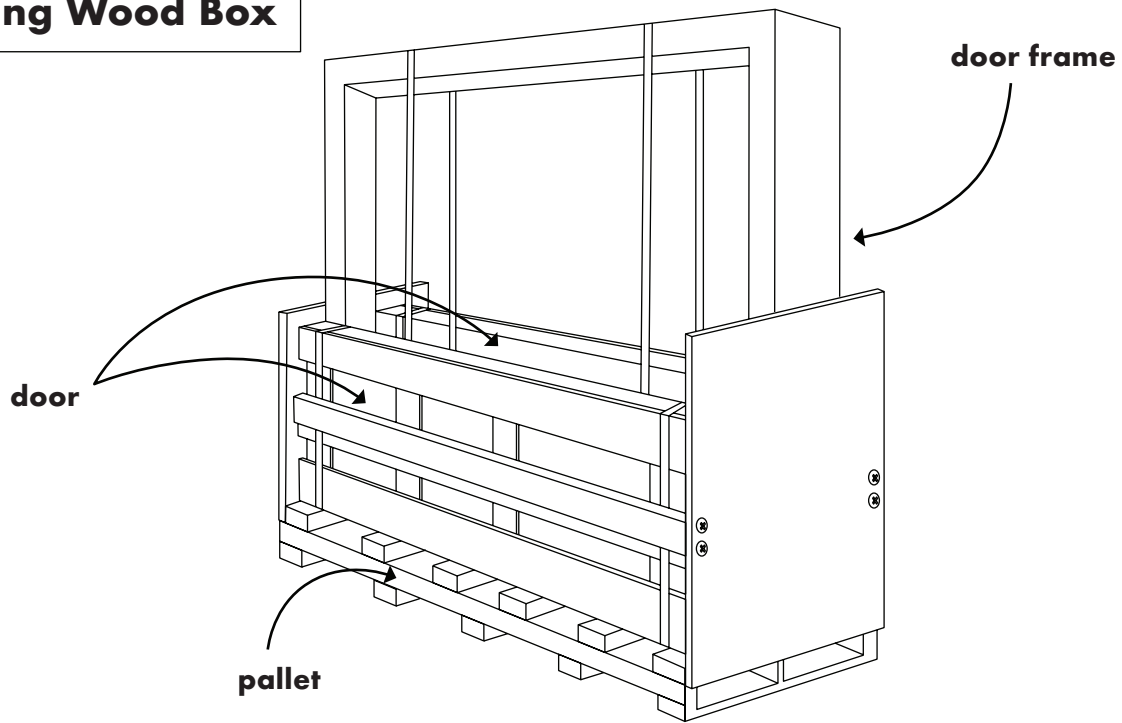

### Installing Door Frame with Sidelights

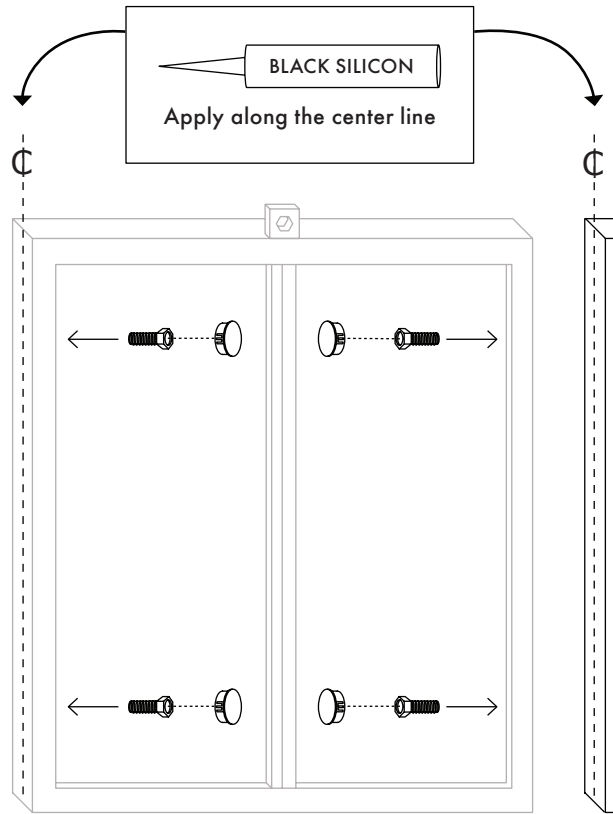
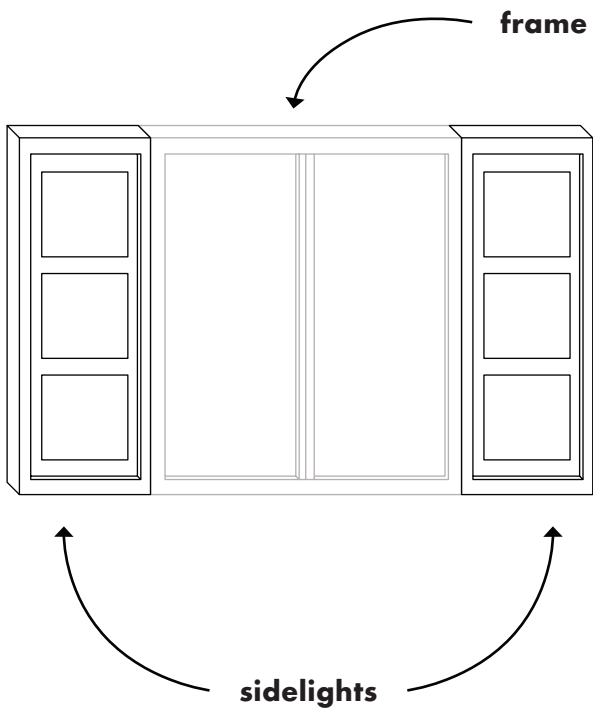

### Installing Door Frame with Transom

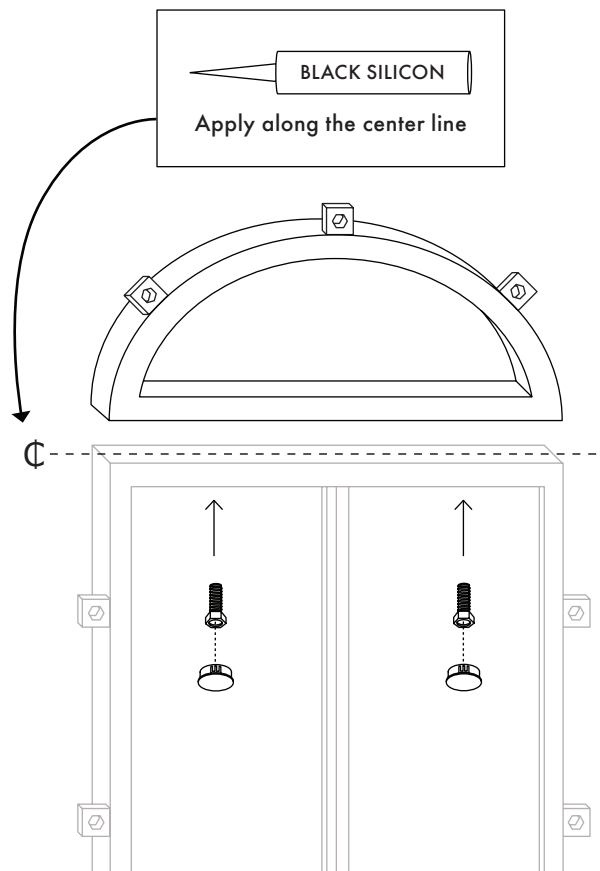
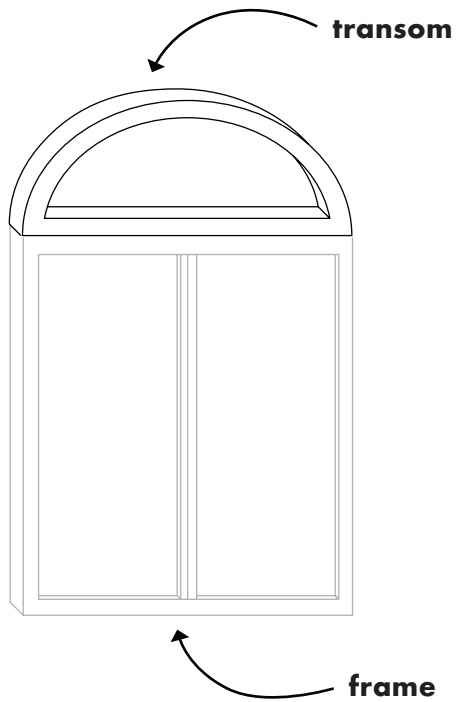

### Leveling Door Frame

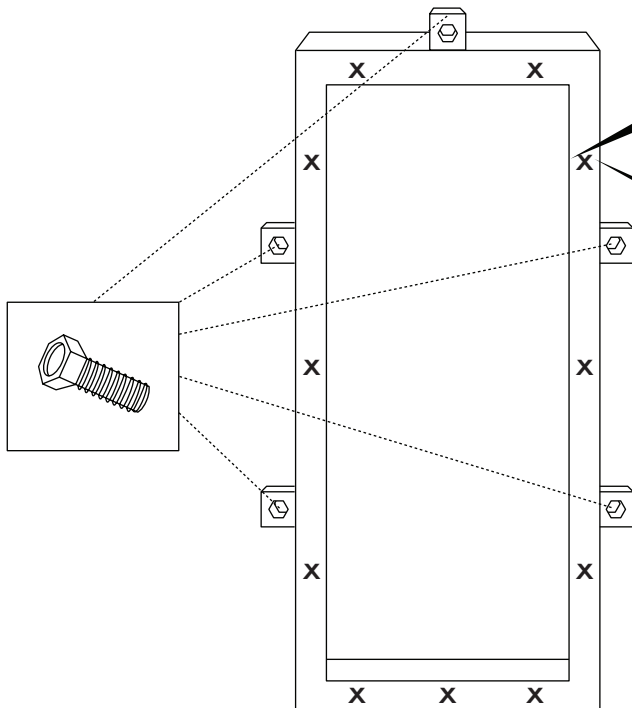

\*Level on all "X" marks\*

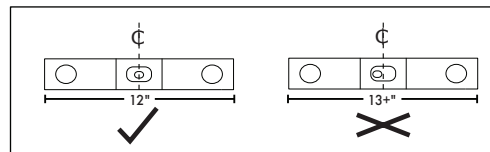
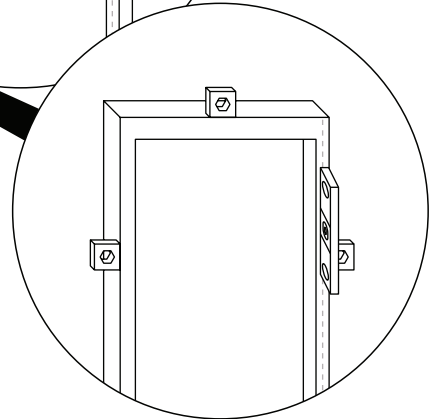
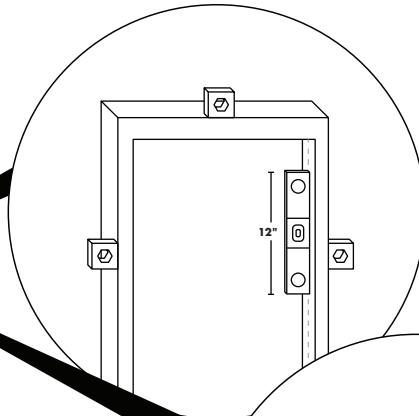

### Hanging the Door

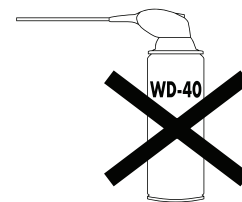
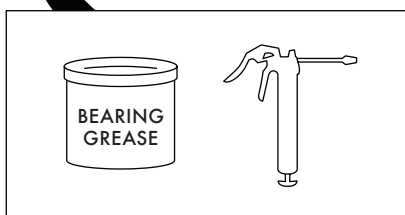
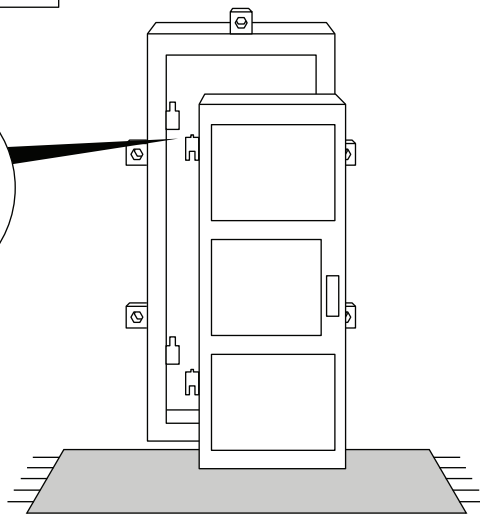
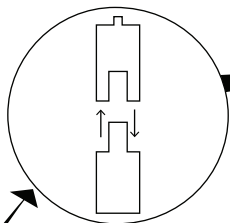

# Door Fit Adjustment

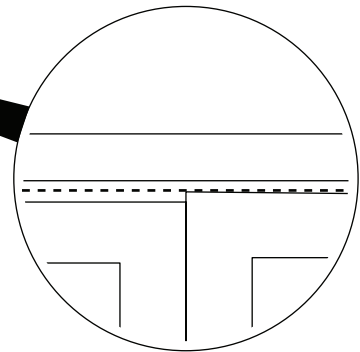
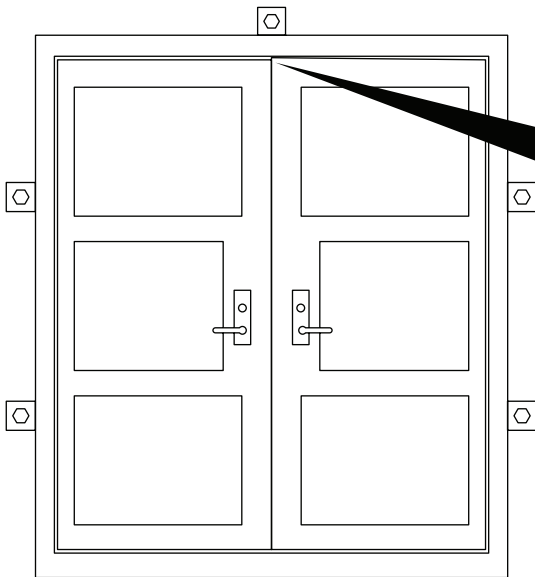
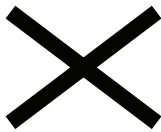
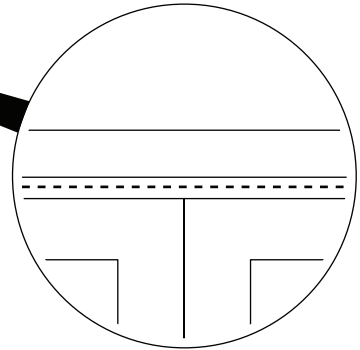
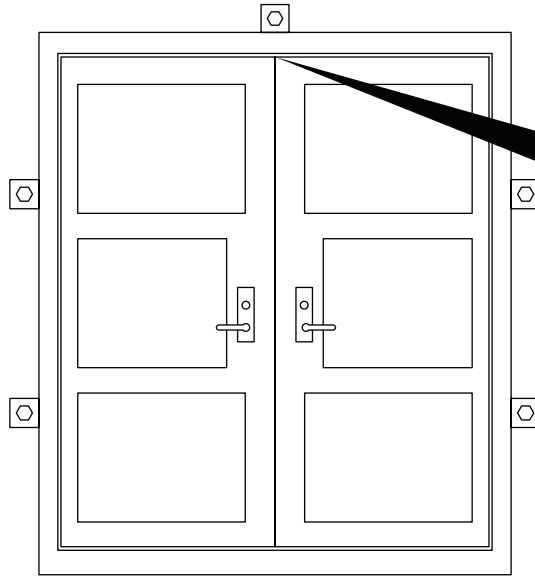

\*Use plastic shims on lower corner side to level doors and then relevel\*



# Door Fit Adjustment

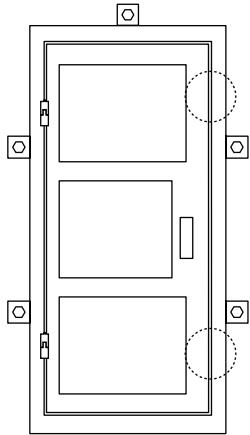

\*Make sure circled areas are flushed from inside the house\*

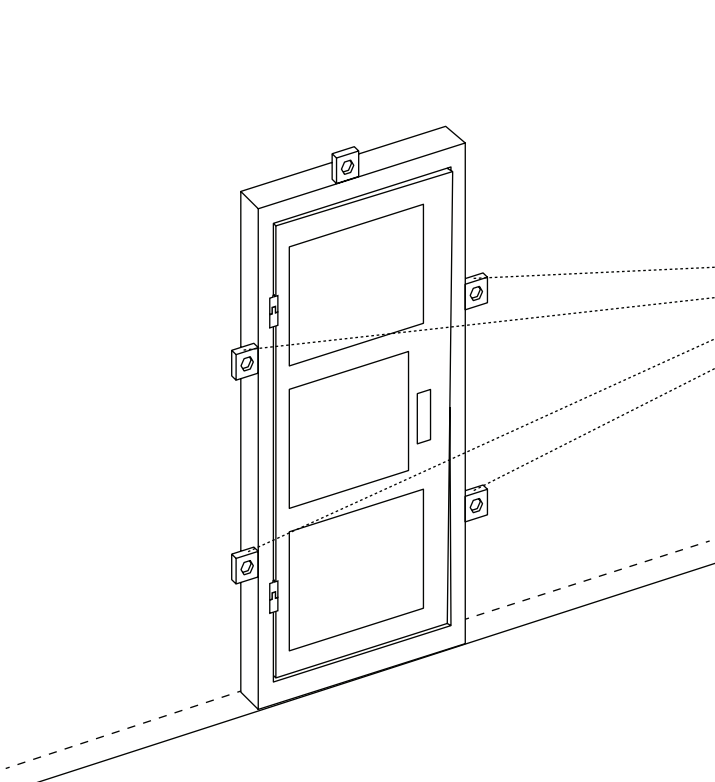
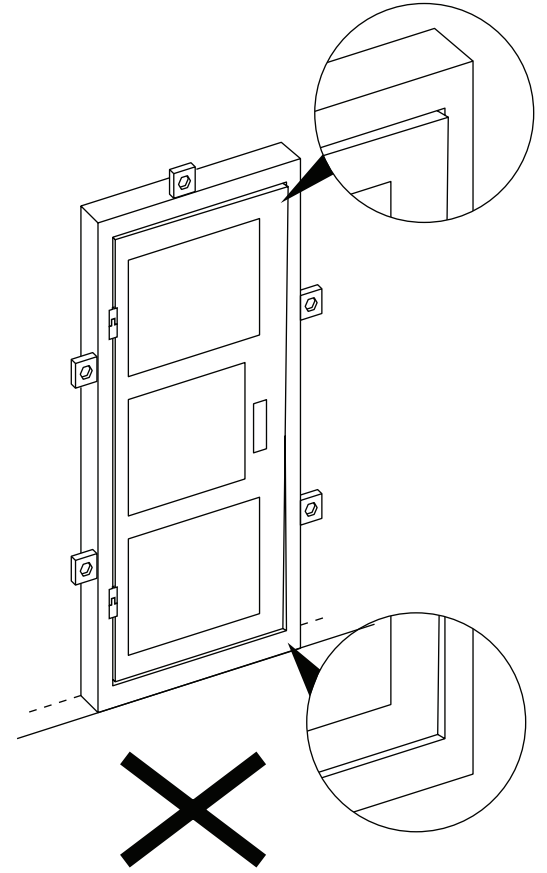
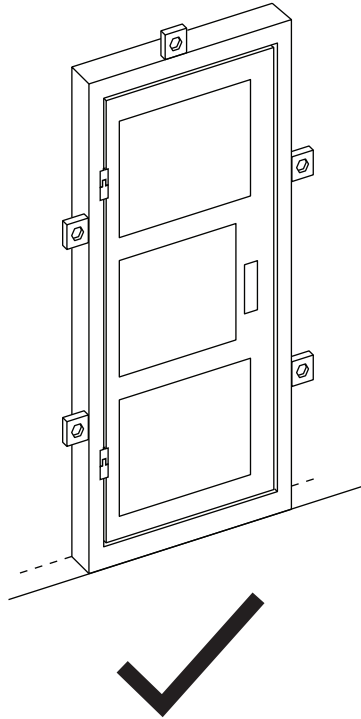

\*Use plastic shims to adjust these areas if door fit is uneven and then relevel\*

# Door Fit Adjustment

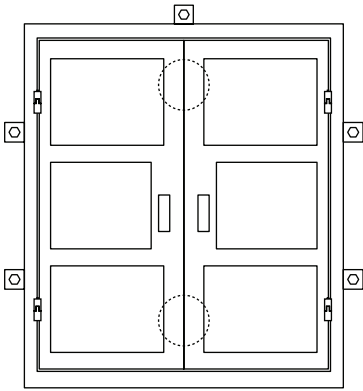

\*Make sure circled areas are flushed from inside the house\*

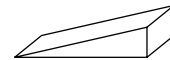
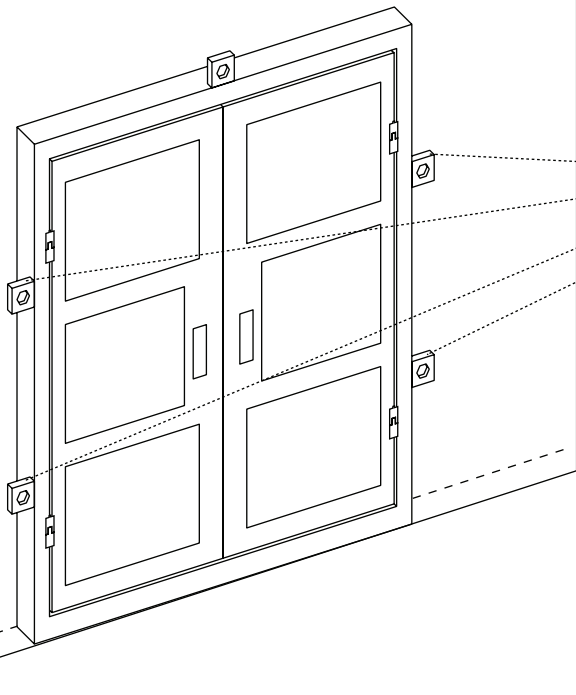
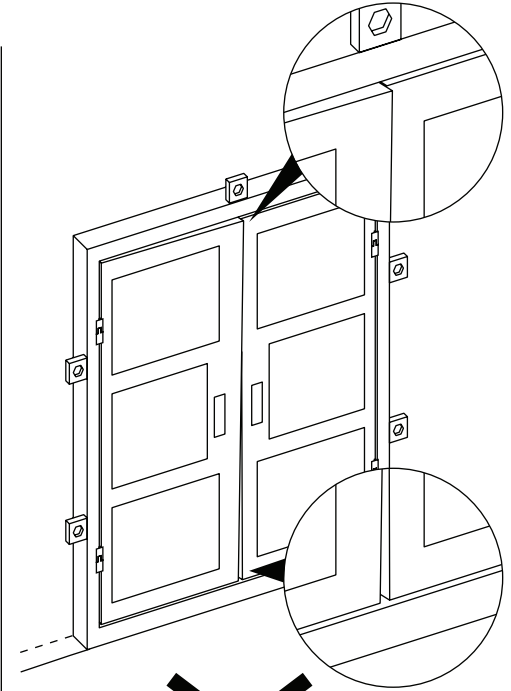
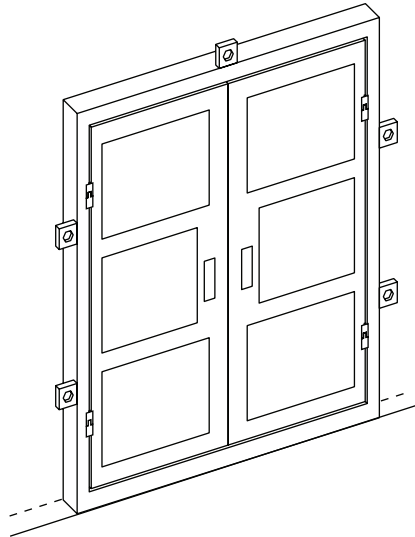

\*Use plastic shims to adjust these areas if door fit is uneven and then releve!\*

# Roller Catch

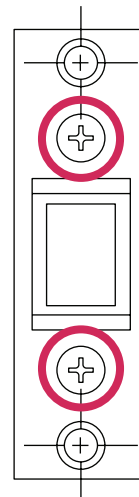
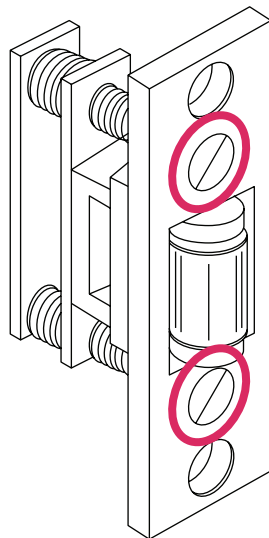
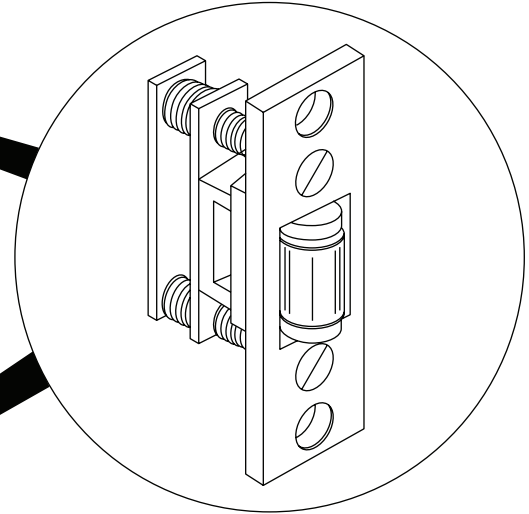
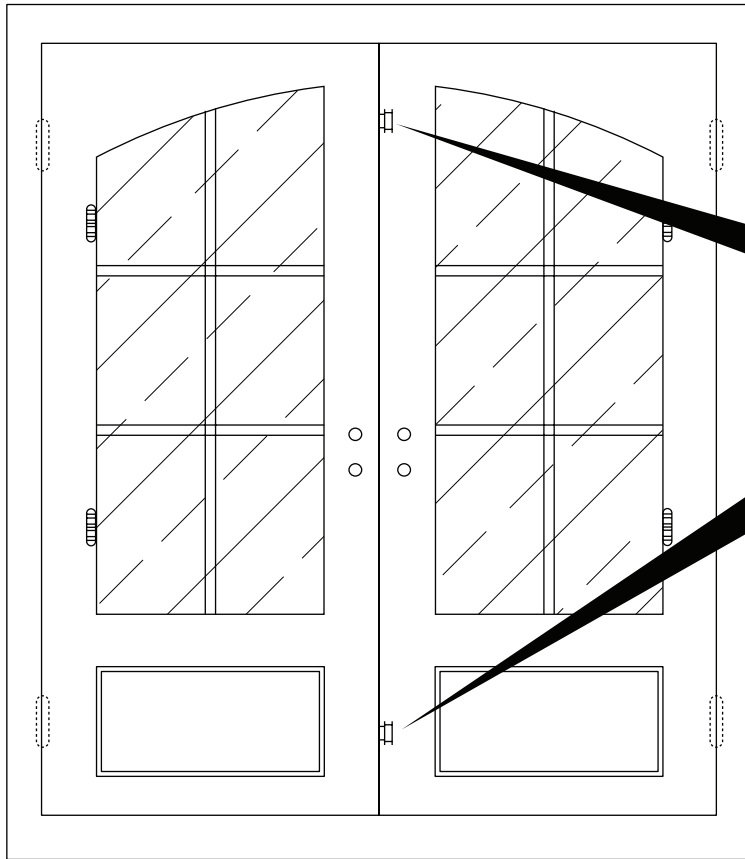

**\*Red marks are the amusement\***

## LOCK STRIKE PLATES

File the sides here

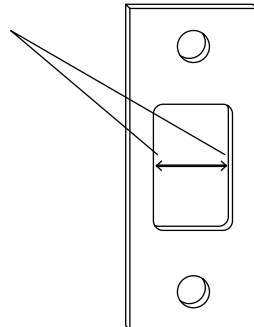

**Filed**

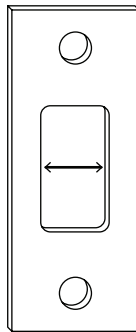

**Not Filed**

Enlarge screw locations if necessary

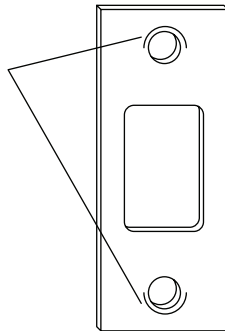

If the door is not 100% level (And even with the door being level, the strike plate may still require some filing adjustments), the latch and deadbolt strikes will not strike correctly into the opposing strike plate. In this case, you will need to file down the opening of the strike plate in order for the latch to secure correctly.

On a wooden door, it is easy to notch out the wood to change the location of the strike plate, but because an iron door is metal, instead of cutting and welding new metal, this filing of the plate is the solution for small strike issues. Our strike areas are standard\* sizes and the plates can be purchased at your local hardware store.

Please reference the diagram on the left for an example of a strike plate that has been filed vs. one that has not.

There are also times when the screw locations on the strike plates may not line up 100% perfectly with the threading on our doors. In this case, you will need to drill the holes larger to align the screw holes. The bottom left diagram shows those locations as well.

\*Filing adjustments may be needed depending on the lock manufacturer as they may not provide the correct size strike plate for our metal doors.



Pinky's Iron Doors does not recommend spray foam for install

# Interior Frame Assembly

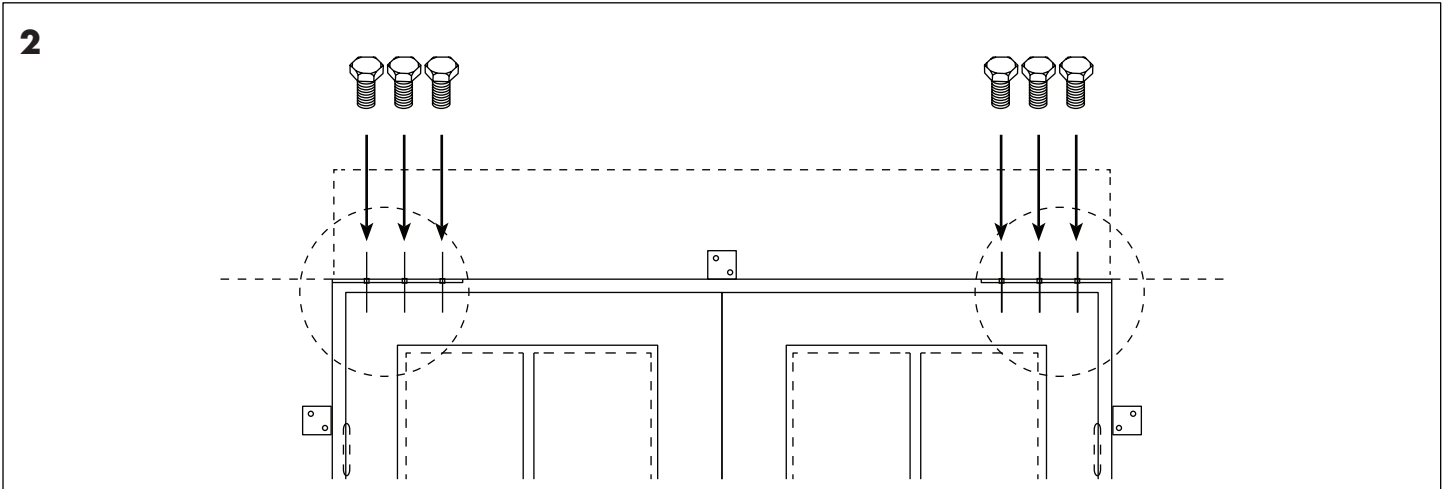
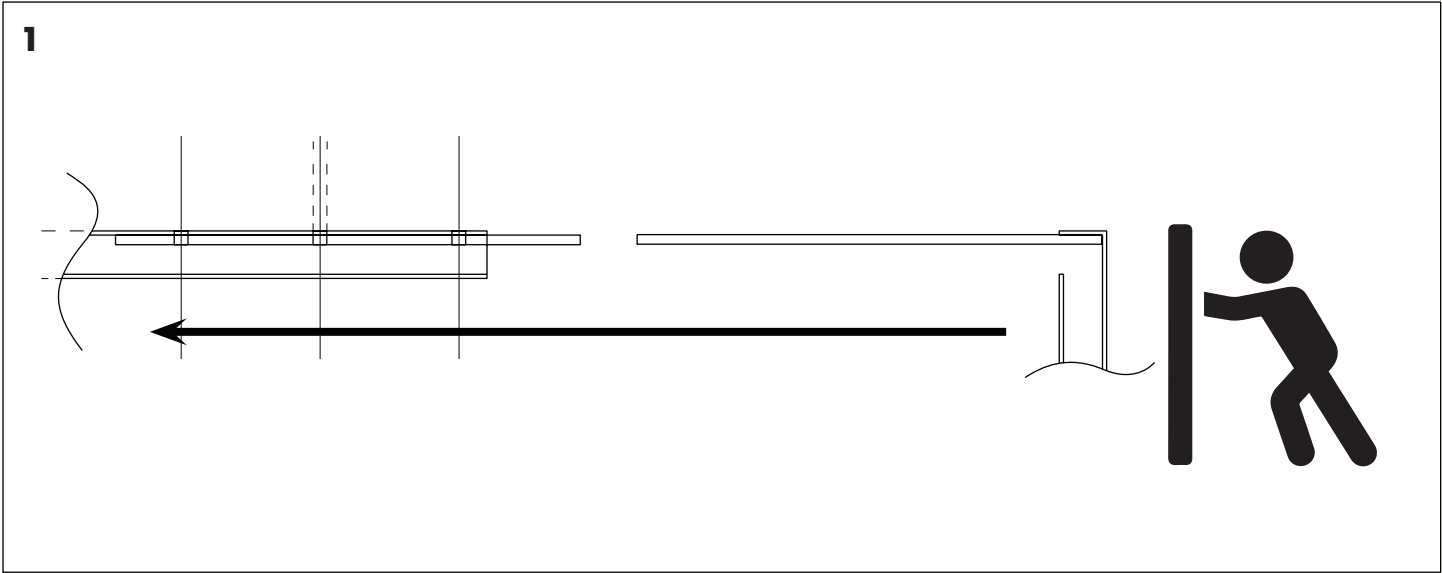
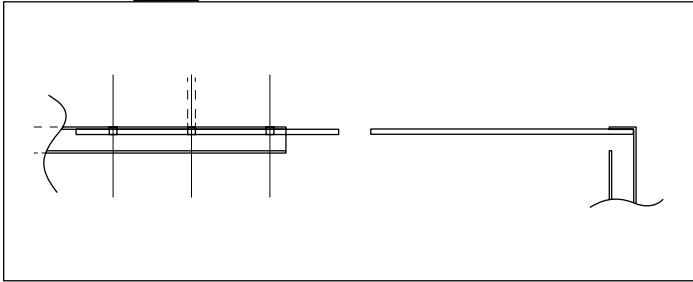
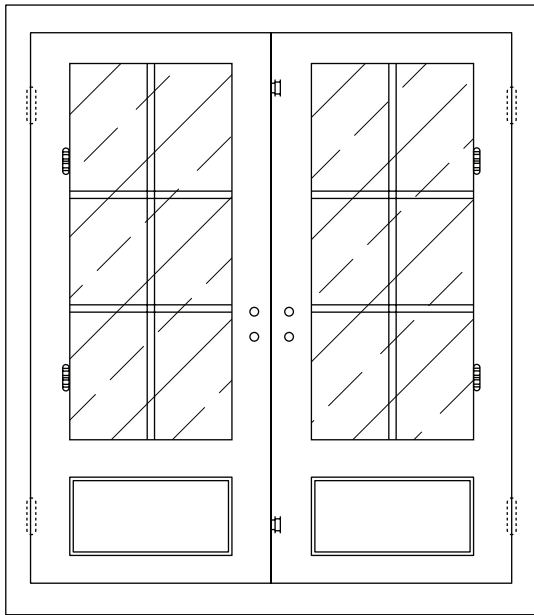

# Installing a Barn Door

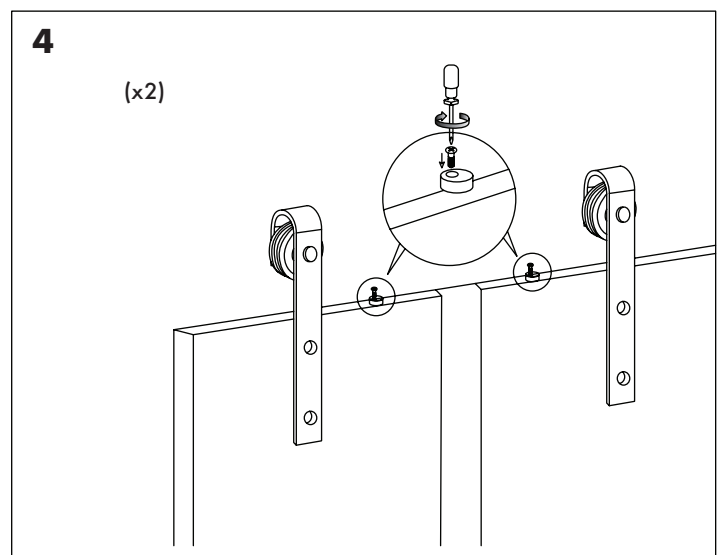
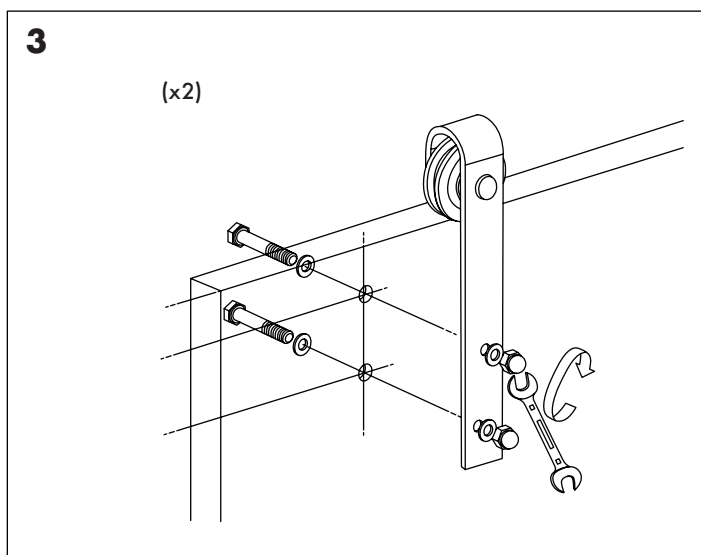
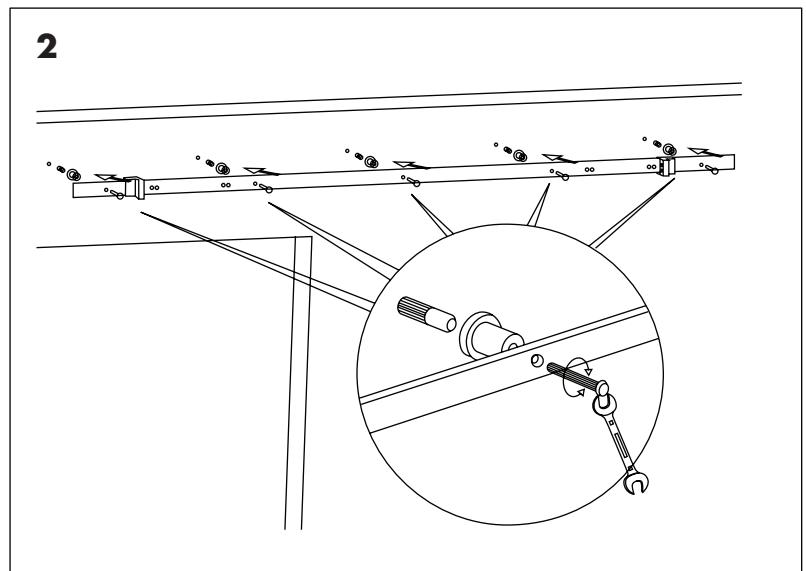
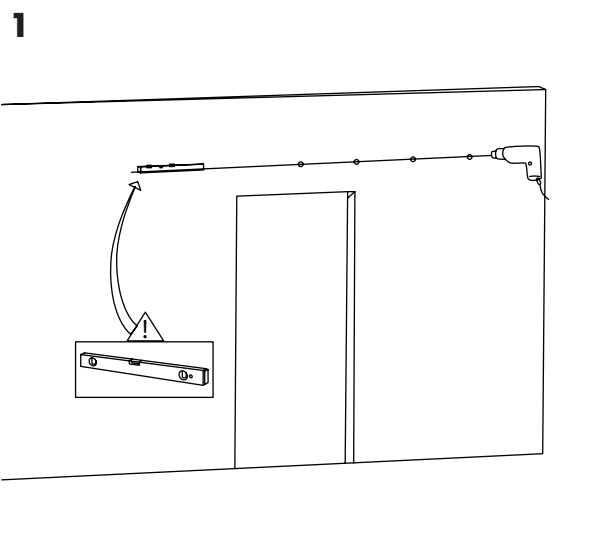
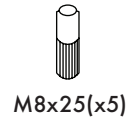
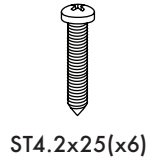
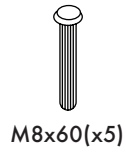
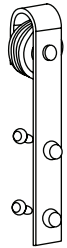
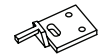
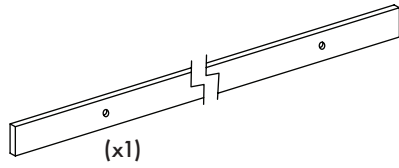

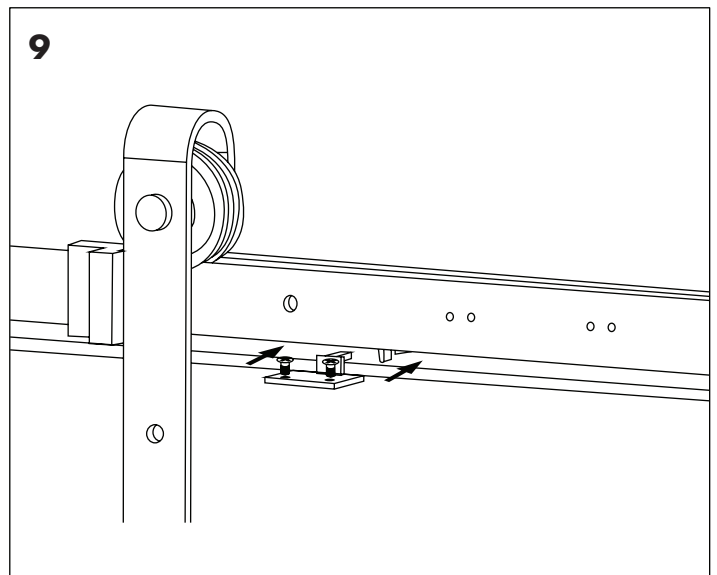
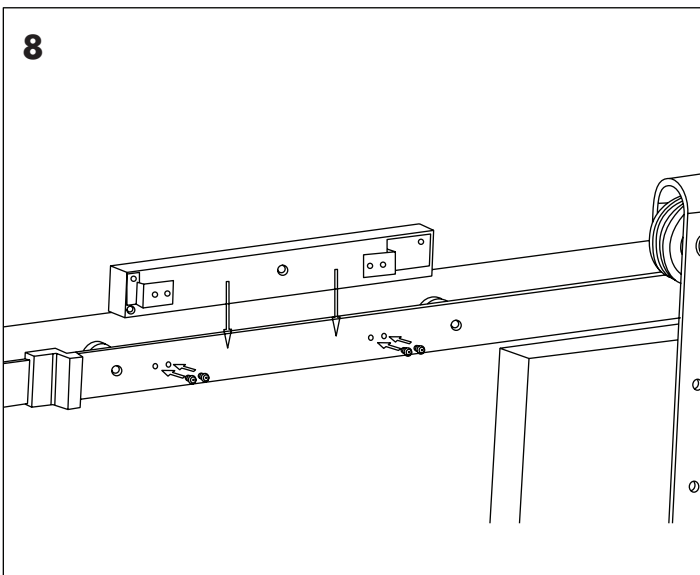
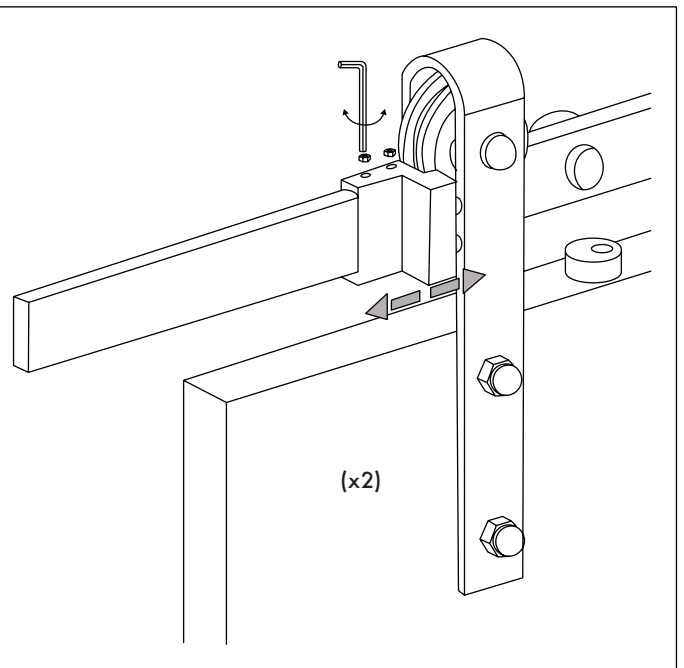
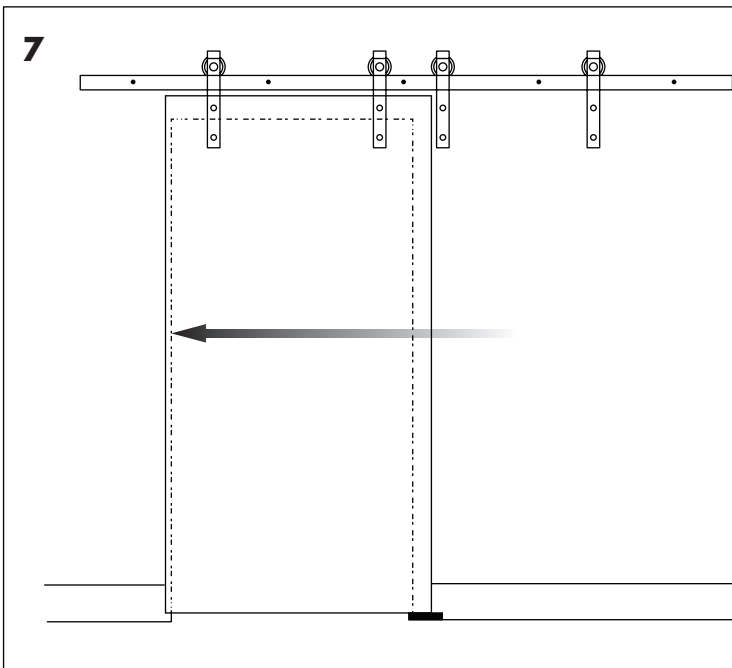
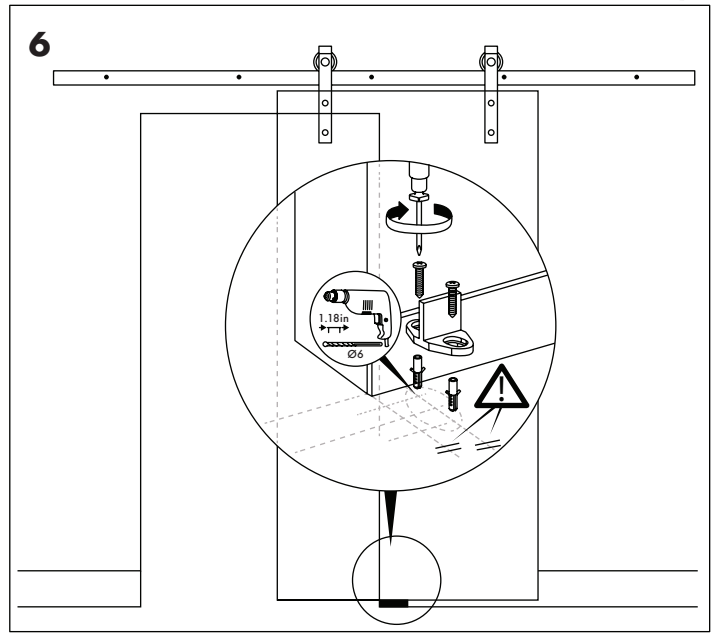
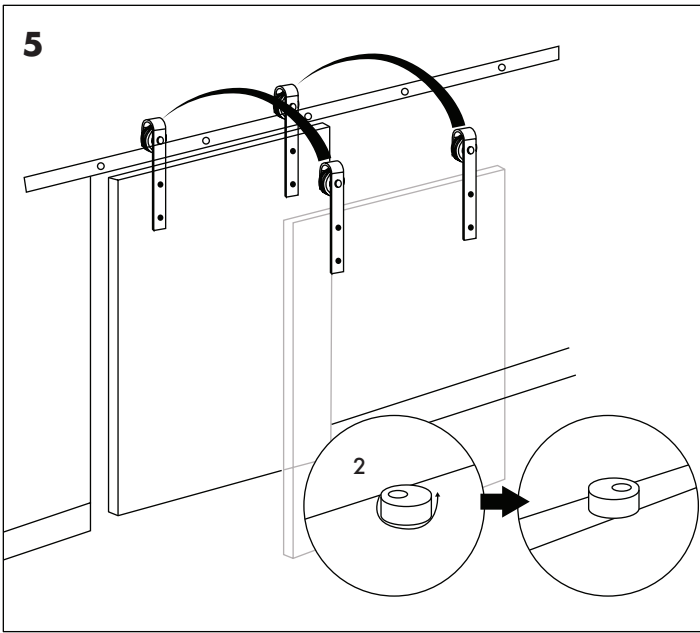

# Installing a Bi-Fold Door

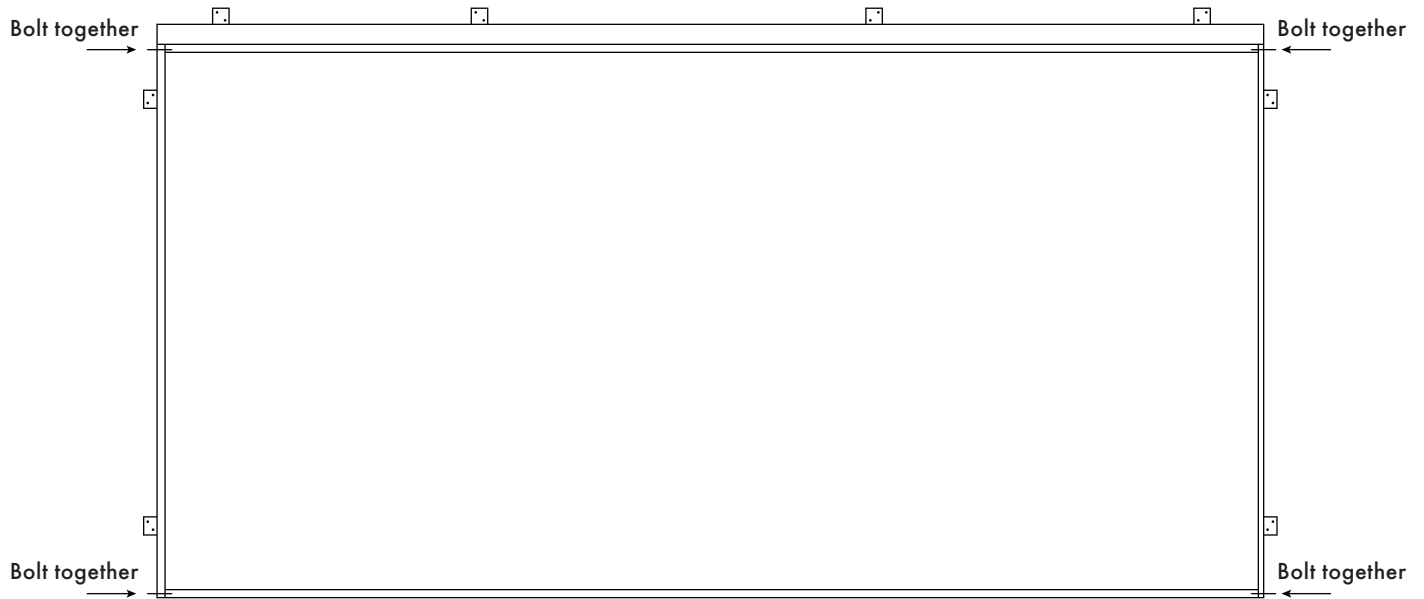

## 1 Frame Assembly

Use **M8 \*50 Screws** to bolt header/side jambs/threshold together

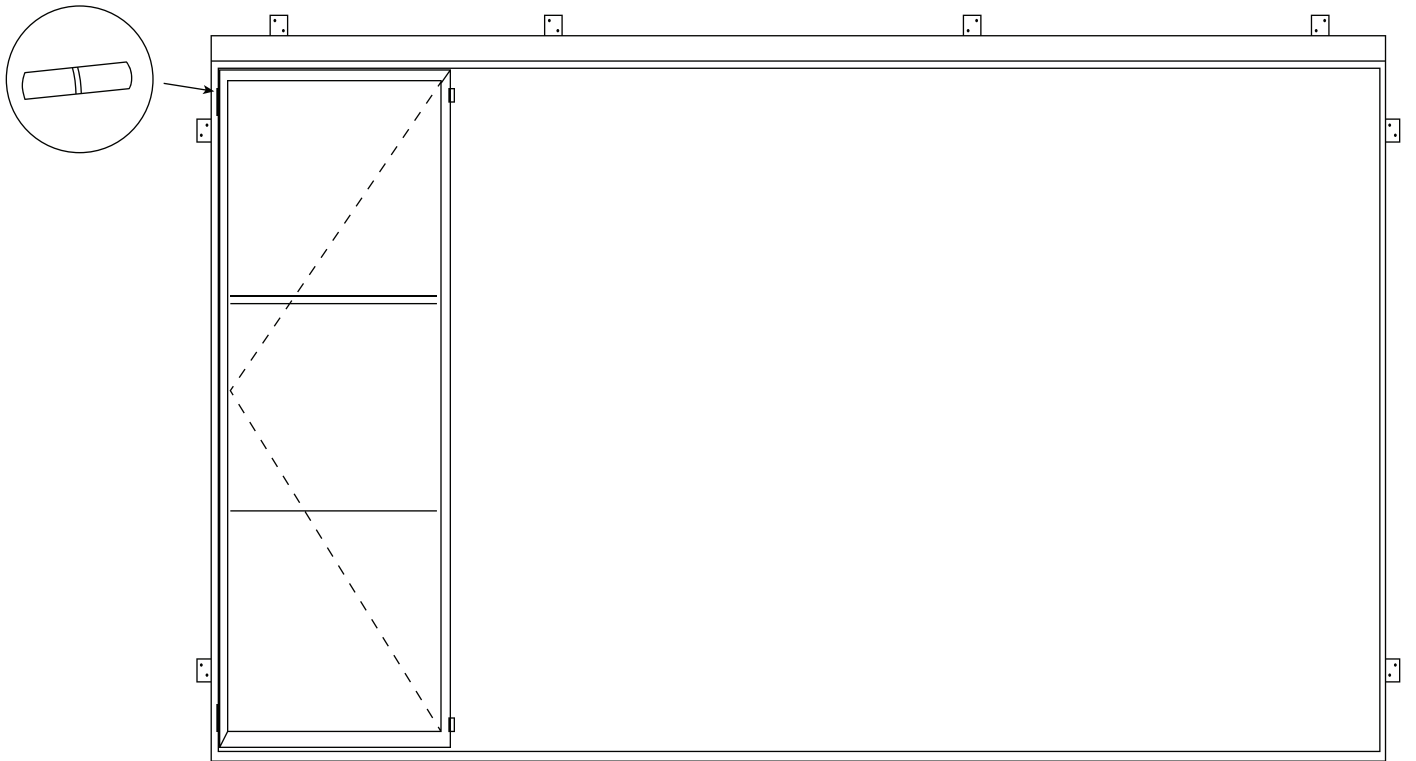

## 2 Hang the 1<sup>st</sup> door



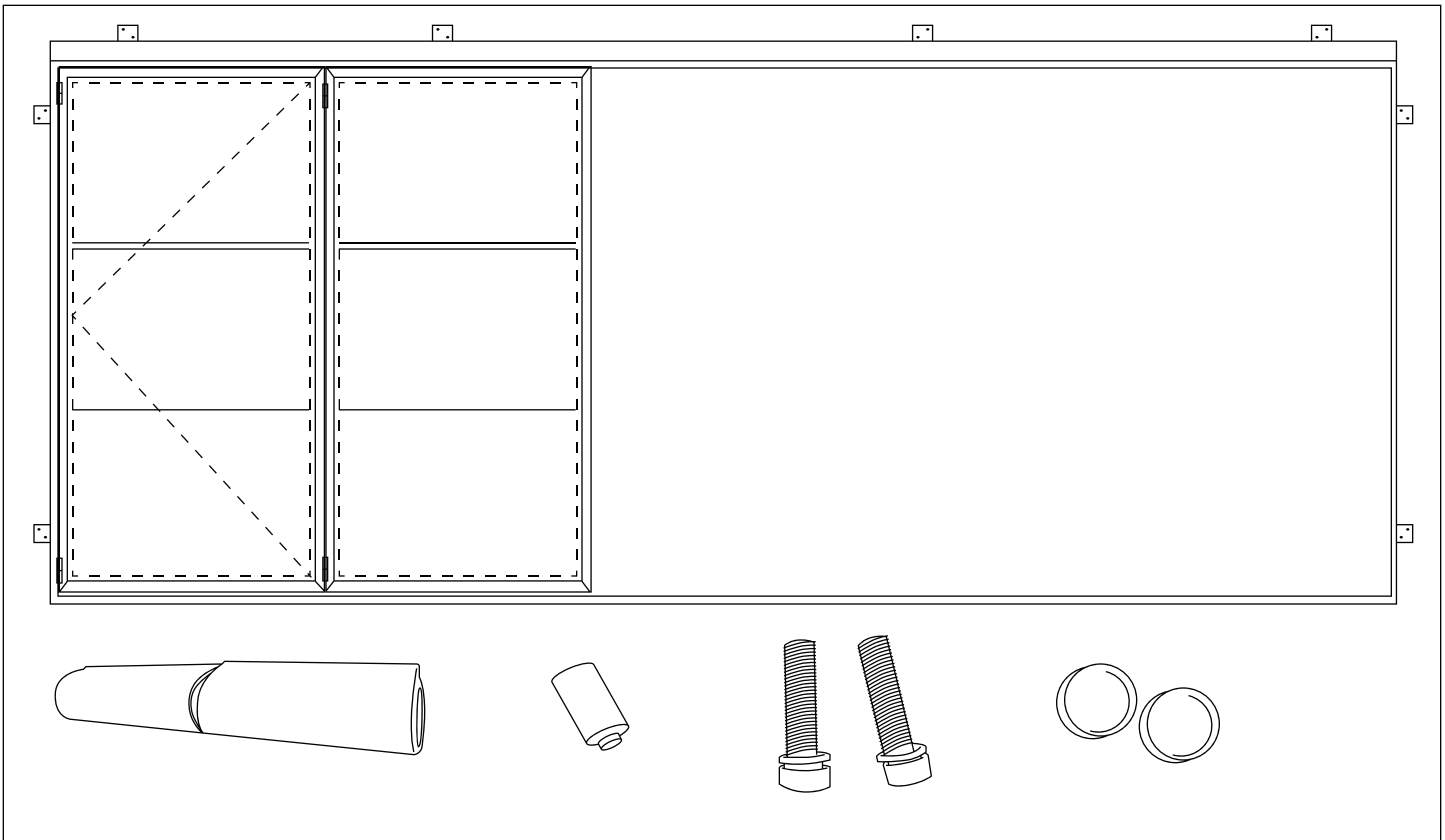

### 3 Hang the 2<sup>nd</sup> door

1. Put the **ajustion pin** in the **bottom hinge**
2. Put the **bolt** in and screw tight
3. Put **plastic cap** on **bottom hinge**

### 4 Hang the 3<sup>rd</sup> door

1. Put the **roller** in the **top track**
2. Use the **7" bolt** to connect **roller** and **top hinge** on the 3<sup>rd</sup> door
3. Put the **small screws** on **bottom top hinge**
4. Use the **6" bolt** to connect the **bottom slide** and **bottom hinge** on the 3<sup>rd</sup> door

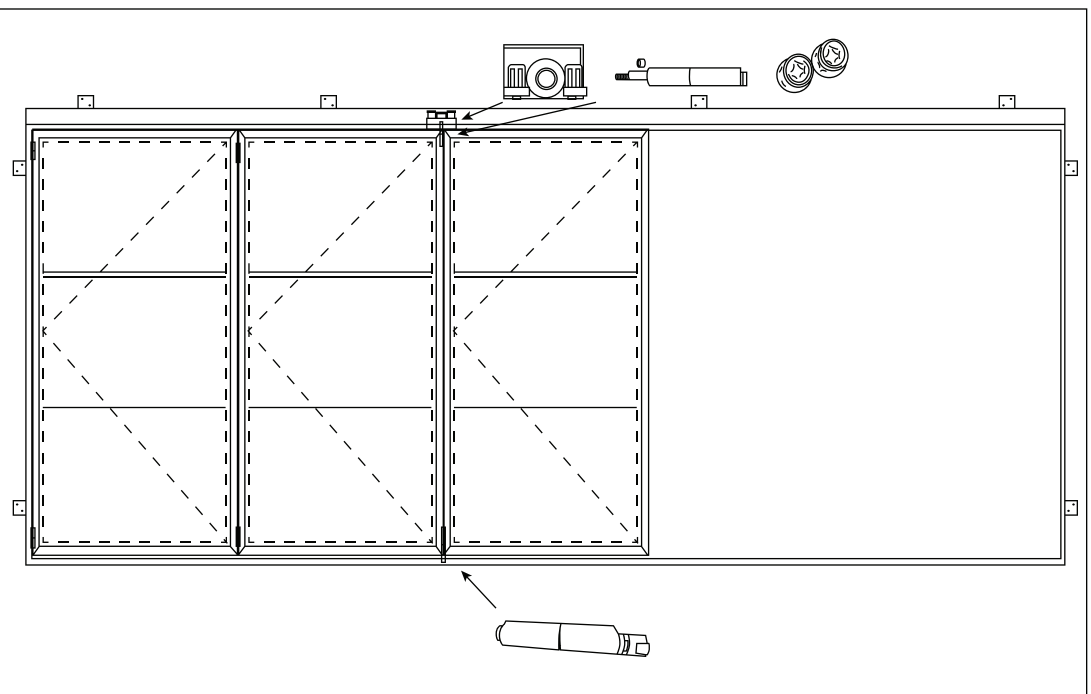

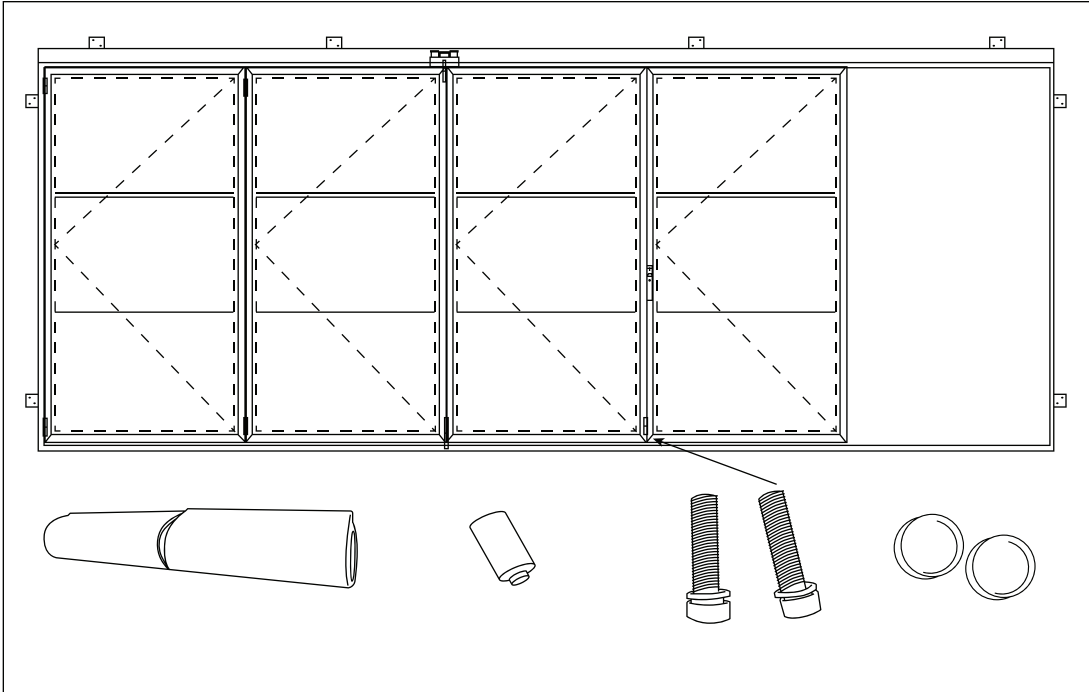

**5** Hang the 4<sup>th</sup> door

- 1.** Put the **adjustment pin** in the **bottom hinge**
- 2.** Put the **bolt** in and screw tight
- 3.** Put the **plastic cap** on **bottom hinge**

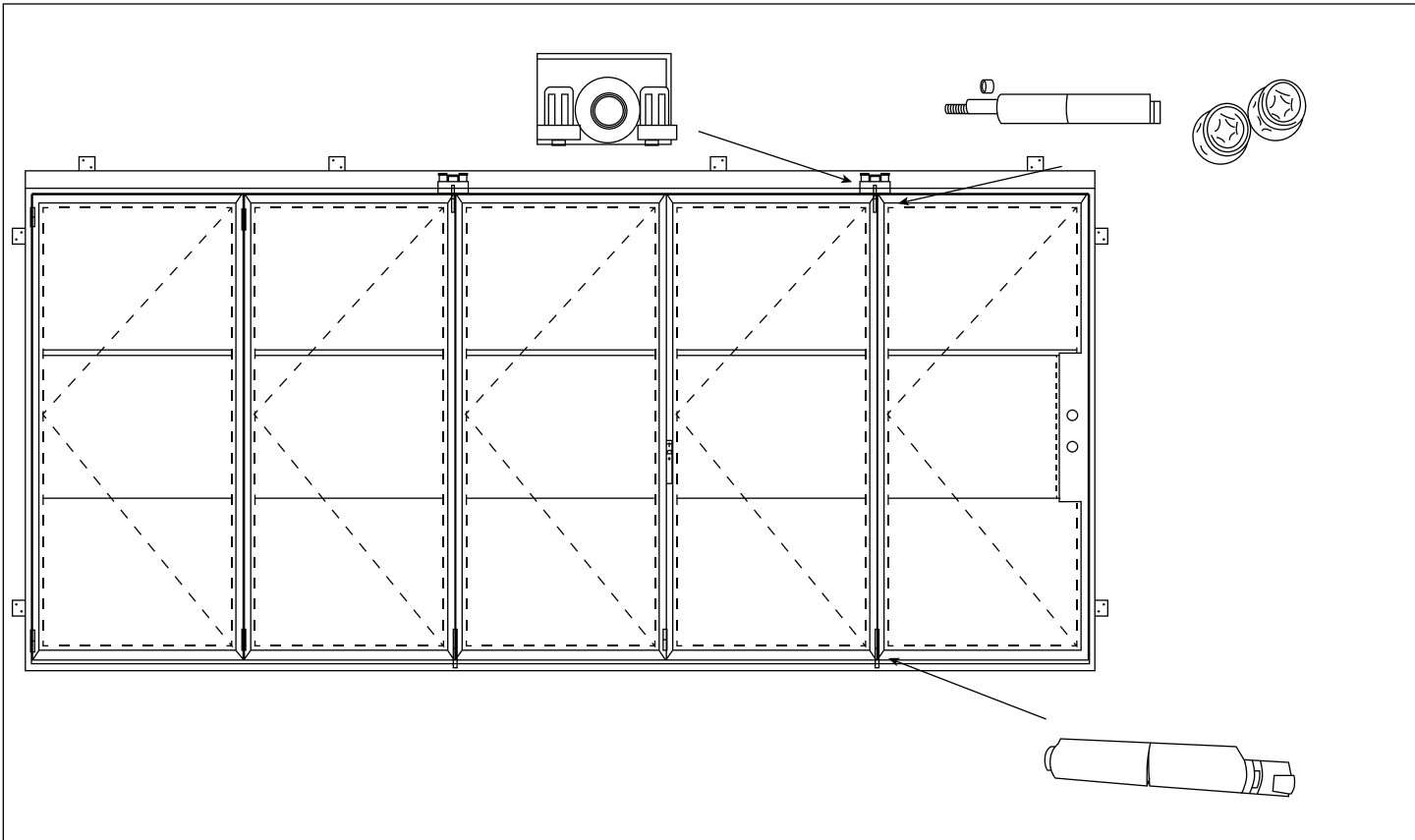

**4** Hang the 5<sup>th</sup> door

- 1.** Put the **roller** in the **top track**
- 2.** Use the **7" bolt** to connect **roller** and **top hinge** on the 3<sup>rd</sup> door
- 3.** Put **small screws** on the **bottom hinge**
- 4.** Use the **6" bolt** to connect the **bottom slide** and **bottom hinge** on the 3<sup>rd</sup> door

## STORING OF DOORS & FRAMES

### Avoid Damage to Finish on Door and Frame

**Pinky's Iron Doors is not responsible for any damages due to improper storage or exposure to moisture, water, or humidity.**



Our doors and frames are packaged for transport only. The plastic wrapping is only for shipping purposes and will not protect doors and frames against elements such as water moisture\* or humidity\*\*. Please make sure to remove both doors and frames from all packaging if you will be storing them for a future install date. Use towels and make sure to store in a safe place as the frame is top heavy.

Please reference the photo on the left for an example of paint bubbling that may be caused by water/humidity if stored in plastic wrapping and left enclosed.

\*Avoid any type of moisture from getting into packaging as it will not be able to escape and will cause the paint to bubble or rust.

\*If your doors/frames happen to get wet, they **MUST** be wiped down **IMMEDIATELY**.

\*If your doors/frames get wet during offload or during storage, remove doors from the box immediately to avoid damage.

\*\*Doors/frames that will be stored in humid areas will also need to be opened from transportation package immediately to avoid damage.

## CLEANING & MAINTAINING IRON/STEEL DOORS & WINDOWS

**Avoid Damage to Finish on Door and Frame**



It is important to maintain your new iron/steel doors and windows throughout the year. We recommend you wipe down your door/window at least once a month with a spray on automotive wax.

**DO NOT USE ANY WATER, CHEMICAL CLEANING AGENTS, AND/OR ANY KIND OF SOAP (INCLUDING, BUT NOT LIMITED TO, DISH SOAP, LAUNDRY DETERGENT, BODY SOAP, ETC).**

Using water, soap, and chemical cleaning agents will lead to rust and cause the paint on the door to dry out (removing the moisture from the paint), and may eventually lead to cracking/peeling of paint, discoloration, etc, over time.

### Hinge Maintenance

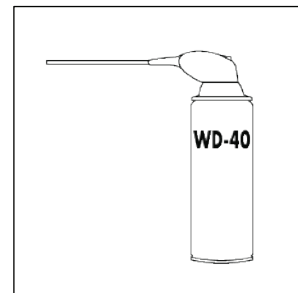
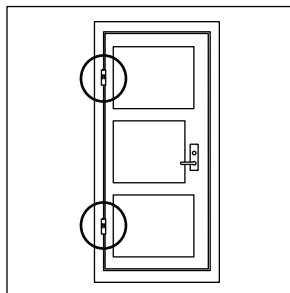
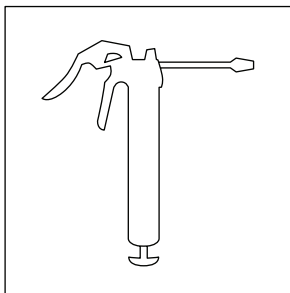

Please grease the hinges once a year at the bare minimum, but if you hear squeaking noises, please grease them right away. Failure to do so will result in the hinges breaking due to friction.

**CAUTION:**  
**ONLY USE BLUE PAINTERS TAPE**  
**ON PINKY'S PRODUCT**

**Avoid Damage to Finish on Door and Frame**

**Pinky's Iron Doors is not liable for any damages caused by misuse of tapes and adhesives on your Pinky's product.**



Please do not use any tape or adhesive other than blue painters tape to mask, cover, or for any purpose on your Pinky's products.

If the blue painters tape is needed for extended amounts of time, please replace tape regularly as the sun can bake the adhesive onto the painted area.

If you must use red duct tape for stucco work or otherwise, please first apply the blue painters tape and mask with red duct tape over the blue painters tape to avoid any contact with the door/frames paint itself.

Using any other type of tape directly on your Pinky's products will result in peeling/bubbling of the paint, as seen in the photo on the left.

## **NEED HELP?**

**If you need installation assistance, please contact us at:  
support@Pinkysirondoors.com or (844) 843-6677.**

We provide free remote support only and will not come out to job sites.

If you have any installation issues or questions, please send us an email with all necessary (well-lit & quality) photos along with an explanation regarding the issue. One of our technicians will review your inquiry and guide you through email or phone.