

POWERTUNE DIGITAL CAN I/O EXTENDER USER MANUAL (V2.0)

FULL MANUAL: <https://www.powertunedigital.com/pages/manual>

Thank you for your purchase of the PowerTune Digital CAN I/O extender!

Terms & Conditions:

It is recommended that your CAN I/O EXTENDER is installed by a trained professional. Incorrect installation can result in damage to your vehicle, electronics or components. Vehicles & vehicle components are not considered part of Powertune Digitals warranty repairs.

- Never short-circuit the wires of the vehicle's wiring loom or the inputs/outputs of the CAN extender.**
- All modifications to the vehicle's wiring must be performed with the positive terminal of the battery disconnected.**
- It is critical that all connections in the wiring are properly insulated and that no metal wiring is left exposed after installation has been completed.**

Broadcasting CAN IDs on your vehicle's can-bus that conflict with existing addresses already used by the ECU/manufacture could interfere with any vehicle system, safety systems, or any critical vehicle systems (airbags, brakes, cruise control). It is vital to ensure the correct procedure is followed to identify and set the correct CAN addresses to be broadcast by the CAN extender.

Warranty:

PowerTune Digital's products are manufactured to high quality standards and are put through thorough tests and inspections before they are sold to you.

PowerTune Digital provides a 12 months warranty against defects in relation to the hardware components of our products on the terms of our Warranty Sheet.

PowerTune Digital products are designed for off road use only.

PowerTune Digital will not be liable for any incidental, special or consequential loss or damages, or damages for loss of data, business or business opportunity, goodwill, anticipated savings, profits or revenue arising under or in connection with any products we sell, except to the extent this liability cannot be excluded under the Competition and Consumer Act 2010 (Cth) or any other applicable law.

**See full warranty terms and conditions at:
<https://www.powertunedigital.com/pages/warranty>**

Table of contents

ITEMS REQUIRED TO COMPLETE INSTALLATION

-Flathead screwdriver, Wire strippers, Crimping tool OR Soldering Iron, Multimeter, Electrical Tape/Heat shrink

-Additional wiring to join/connect the input channel wires to the location of the desired sensor/source

- 240 Ohm Resistors (optional)

-Wire joiners/crimps, OR, soldering iron/solder

-Laptop or USB keyboard

[Section 1 - Powering On](#)

[Section 2 - Termination](#)

[Section 3 - CANdump and Baud Rate Settings](#)

[Section 4 - Analogue and Digital Input Wiring](#)

[Section 5 - Wiring Check](#)

[Section 6 - Dash Settings](#)

[Section 7 - Adding Channels to Layout](#)

Section 1 - Powering On

Ensure all equipment is fully powered down during any wiring (digital dash/vehicle/CAN extender and any accessories). Consult an auto electrician for professional wiring guidance.

14 PIN CONNECTOR A: Ground/earth, CAN-bus, 12v power

Step 1: Begin with **CONNECTOR A** that has the smaller 14 pin plug, by inserting the plug into the can extender box (requires firm press!)

Connect the black ground wire from CONNECTOR A to earth/vehicle ground.	Connect the red power wire from CONNECTOR A to a 12v power source in the vehicle.
--	--

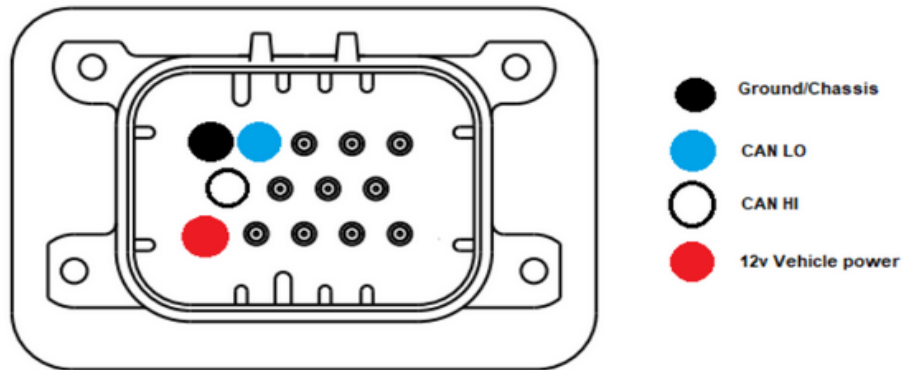

Step 2: Locate the blue and white wires on the same 14 pin connector, connect the blue to CAN-LO on your digital dash, white to CAN-HI on your digital dash. If you already have ECU wires running to your digital dash and cannot insert additional wires, use an electrical joiner to connect multiple CAN wires into a single wire (pictured below).

For now connect only the CAN H/L from the IO extender to the dash - do not yet connect the ECU CAN wiring to the digital dash/extender in order to set the baud rate settings first.

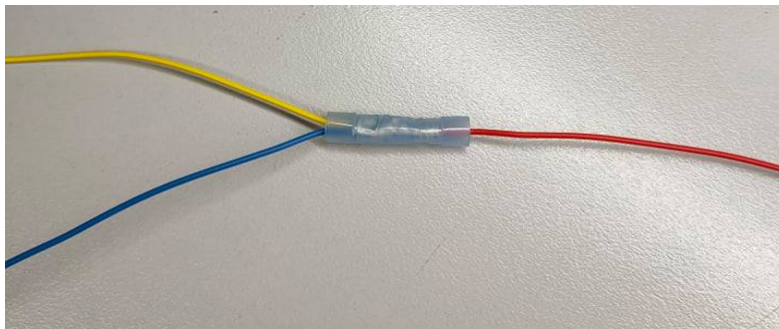

(example of multiple CAN H wires being joined together)

Section 2 - Termination

All digital dashes and CAN I/O Extender Boards come with an internally terminated 120 ohm resistor.

If you are using the CAN I/O Extender in conjunction with a supported ECU, then you will need to remove the termination. Remove the black plastic housing (pinch the sides of the base of the extender box whilst simultaneously pulling the lid up) and softly pull the two plastic jumpers upwards to remove them from the termination pins. Store in a safe place! Default position is to bridge pins 1-2 and 3-4.

See network examples below, the first and last device in line should always be terminated. The “last” device in line is determined by the longest cable length to reach the device.

(located towards the end with the SMALLER 14 pin connector) pictured below:

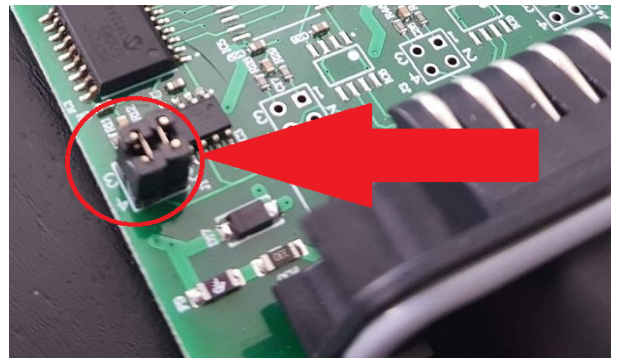
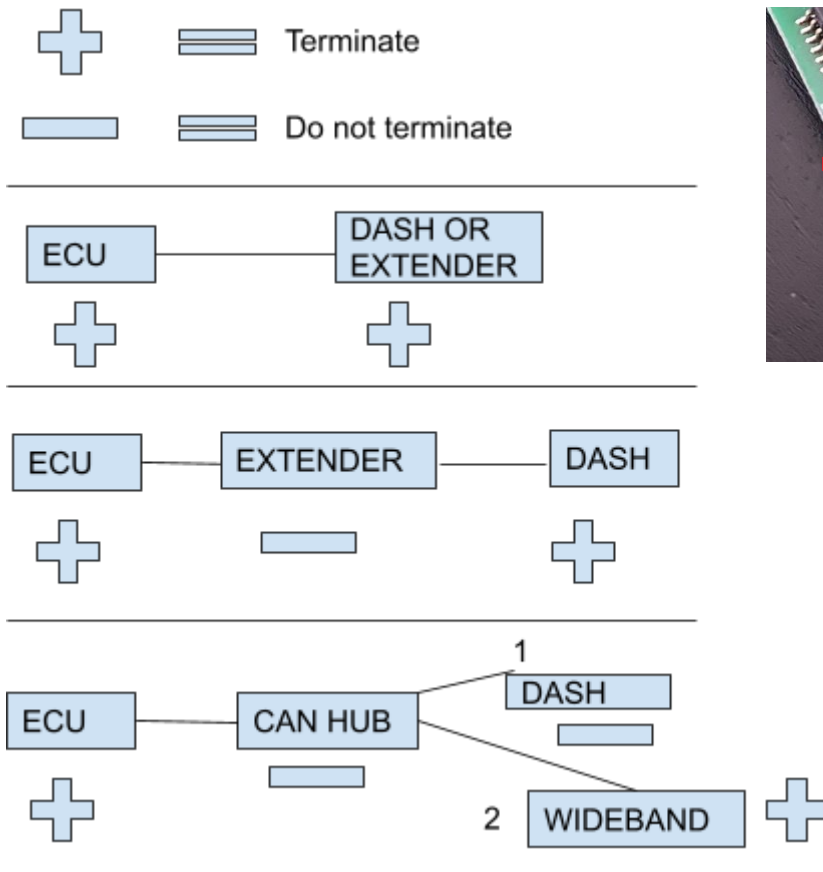

Section 3 - Baud Rate Settings

All CAN extenders ship at a 500KB CAN BITRATE. If you have a factory ECU, the bitrates will already be matched. If you are using an ECU that transmits at a 1MB bitrate (most aftermarket ECUs), you will need to change the bitrate of the extender **before connecting all devices together.**

Determine which bitrate your ECU is using. Connect only the dash and I/O expander together (leave the ECU CAN wiring disconnected from the other devices) and confirm using the below steps that you have connectivity. If your digital dash is set to 1MB bit rate (on the startup tab of the dash settings area), you will need to reduce this to 500KB and press apply before the dash and I/O extender will communicate.

-To ensure that you have wired and terminated the CAN I/O Extender correctly, you will need to check communication with the extender.

1. Turn the car key into Ignition
2. Connect to your Powertune Digital dash via Wi-Fi network from a computer using the program [Putty](http://www.putty.org) (www.putty.org).

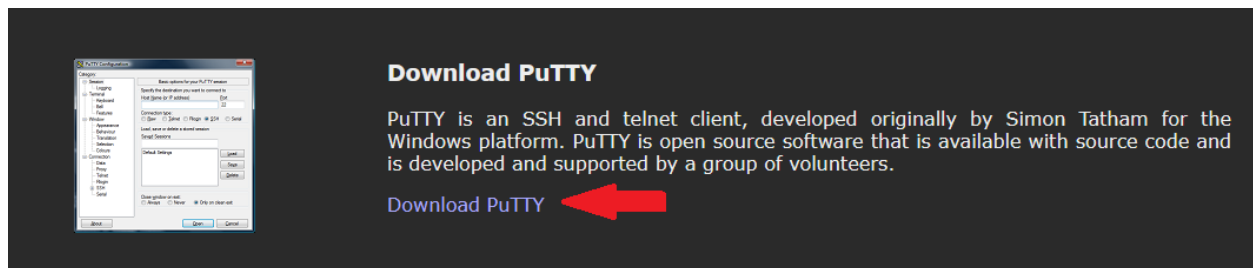

3. Host name is the dash IP address from the network tab.

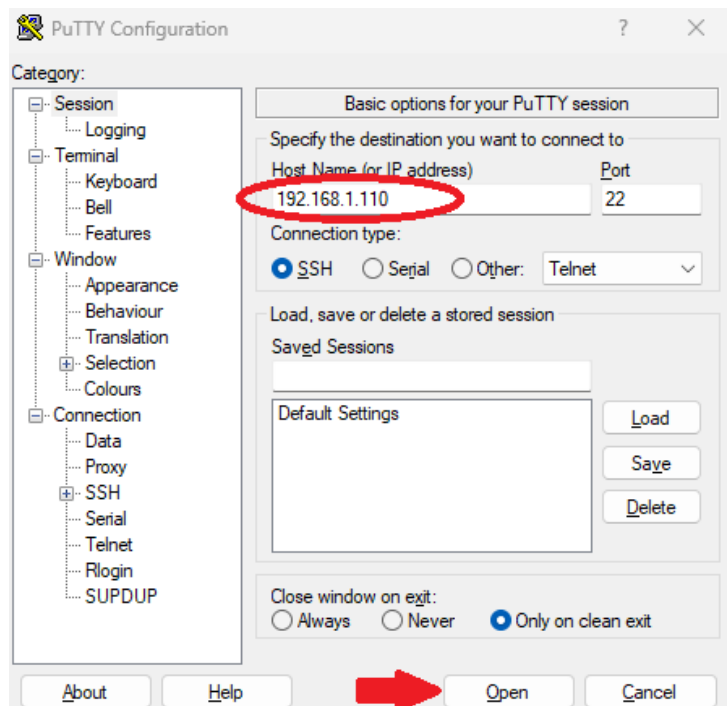
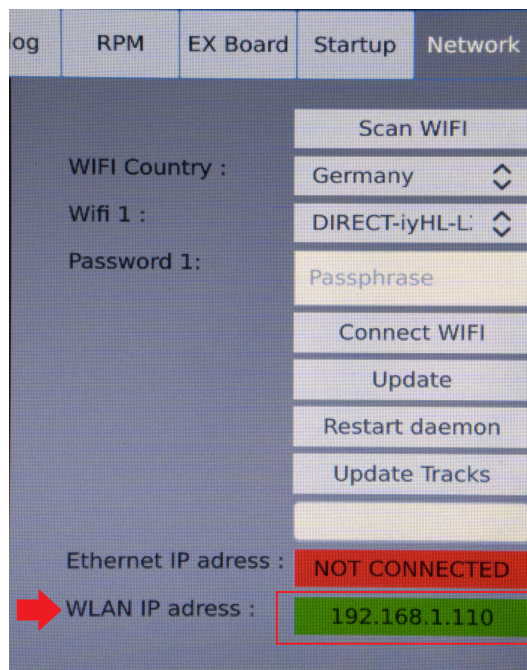

4. Username (**V5 dash**) is “**root**” with no password, or (**V4 dash**) username “**pi**” with password “**raspberrypi**”

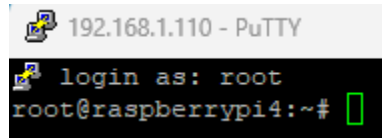

```
192.168.1.110 - PuTTY
login as: root
root@raspberrypi4:~#
```

If you don't have a computer, you can connect a keyboard to your Powertune Digital dash, press “quit” from MAIN settings menu and login using above credentials to access the backend command line (see full instructions in the digital dash [user manual](#))

5. To check if your extender is broadcasting, type the following command and press enter:
candump can0
6. Wait a few seconds, then press CONTROL C

If the CAN I/O Extender is powered and broadcasting correctly, you will see the following IDs in the dump result, 601, 602 and 603 by default

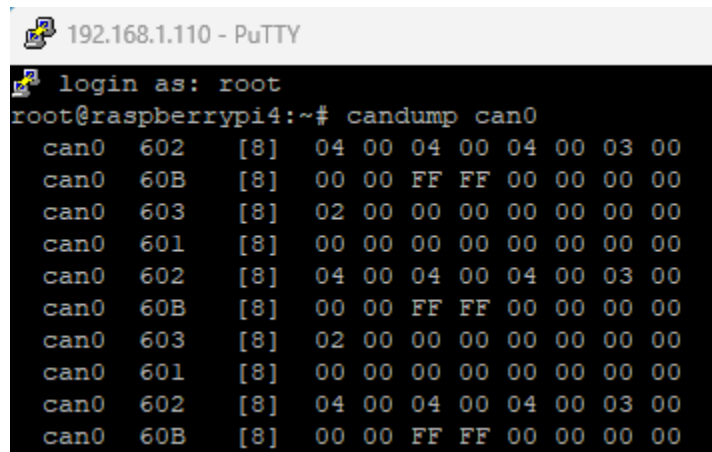

```
192.168.1.110 - PuTTY
login as: root
root@raspberrypi4:~# candump can0
can0 602 [8] 04 00 04 00 04 00 03 00
can0 60B [8] 00 00 FF FF 00 00 00 00
can0 603 [8] 02 00 00 00 00 00 00 00
can0 601 [8] 00 00 00 00 00 00 00 00
can0 602 [8] 04 00 04 00 04 00 03 00
can0 60B [8] 00 00 FF FF 00 00 00 00
can0 603 [8] 02 00 00 00 00 00 00 00
can0 601 [8] 00 00 00 00 00 00 00 00
can0 602 [8] 04 00 04 00 04 00 03 00
can0 60B [8] 00 00 FF FF 00 00 00 00
```

Now that there is communication, identify the correct baud rate for your ECU, and enter each line of command from your laptop/keyboard (note: use shift + \ to get a # symbol on the command line)

Please note that you will need to use different commands for different versions of the Extender. This can be denoted by some hardware differences outlined below:

V1:

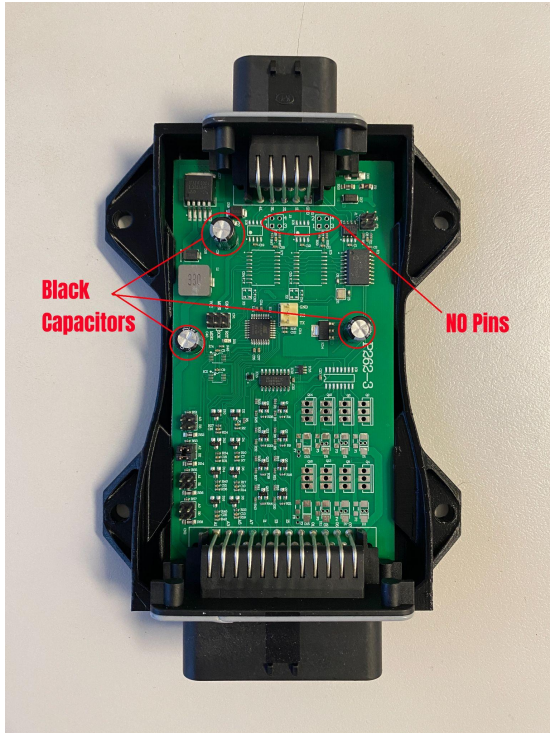

V2:

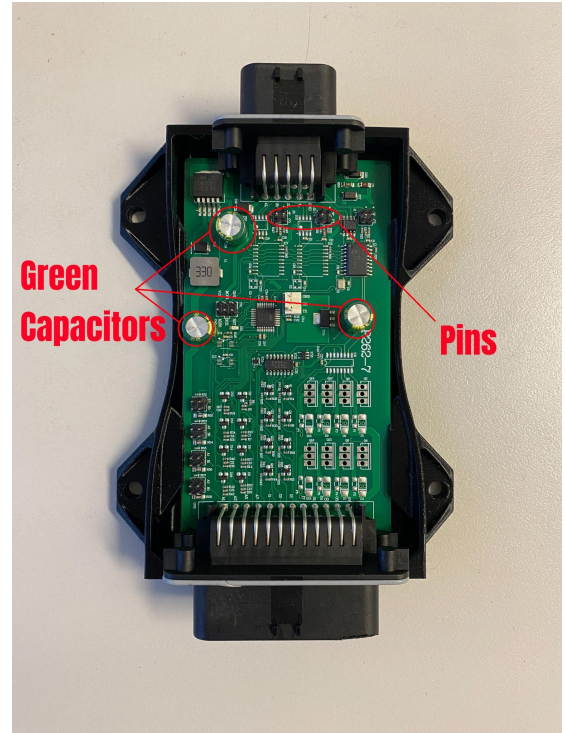

USE for AFTERMARKET ECUs with 1MB BAUDRATE (Link / Haltech / Emtron / Motec / Adaptronic / ECU Master / Microtech / Emerald K3+K6 / Hondata KPRO):

V1: cansend can0 604#00000401

V2: cansend can0 604#0204000000000006

V2: cansend can0 404#0301000000000002

```
can0 602 [8] 04 00 04 00 04 00 03 00
can0 60B [8] 00 00 FF FF 00 00 00 00
can0 603 [8] 02 00 00 00 00 00 00 00
can0 601 [8] 00 00 00 00 00 00 00 00
^Croot@raspberrypi4:~# cansend can0 604#00000401
root@raspberrypi4:~# cansend can0 604#0204000000000006
root@raspberrypi4:~# cansend can0 404#0301000000000002
root@raspberrypi4:~# candump can0
can0 401 [8] 00 00 00 00 00 00 00 00
can0 402 [8] 04 00 04 00 04 00 03 00
can0 60B [8] 00 00 FF FF 00 00 00 00
can0 403 [8] 02 00 00 00 00 00 00 00
can0 401 [8] 00 00 00 00 00 00 00 00
```

USE for Factory/Aftermarket ECUs with 500KB BAUDRATE (Aftermarket ECU: AEM / MaxxECU / WolfEMS / Megasquirt 2-3 / Hondata S300; Stock ECU: GM/+LS / GT86+BRZ / EVO X / 350+370z)

V1: cansend can0 604#00000402

V2: cansend can0 **604**#0204000000000006

V2: cansend can0 **404**#0302000000000001

```
can0 601 [8] 00 00 00 00 00 00 00 00
can0 602 [8] 04 00 04 00 04 00 03 00
can0 60B [8] 00 00 FF FF 00 00 00 00
can0 603 [8] 02 00 00 00 00 00 00 00
^Croot@raspberrypi4:~# cansend can0 604#00000402
root@raspberrypi4:~# cansend can0 604#0204000000000006
root@raspberrypi4:~# cansend can0 404#0302000000000001
root@raspberrypi4:~# candump can0
can0 402 [8] 04 00 04 00 04 00 03 00
can0 60B [8] 00 00 FF FF 00 00 00 00
can0 403 [8] 02 00 00 00 00 00 00 00
can0 401 [8] 00 00 00 00 00 00 00 00
can0 402 [8] 04 00 04 00 04 00 03 00
```

For Factory Ford BA/BF/FG ECUs & WRX ECUs:

V1: cansend can0 604#00000602

V2: cansend can0 **604**#0302000000000001

```
can0 603 [8] 02 00 00 00 00 00 00 00
can0 601 [8] 00 00 00 00 00 00 00 00
can0 602 [8] 04 00 04 00 04 00 03 00
can0 60B [8] 00 00 FF FF 00 00 00 00
can0 603 [8] 02 00 00 00 00 00 00 00
^Croot@raspberrypi4:~# cansend can0 604#00000602
root@raspberrypi4:~# cansend can0 604#0302000000000001
root@raspberrypi4:~# candump can0
can0 601 [8] 00 00 00 00 00 00 00 00
can0 602 [8] 04 00 04 00 04 00 03 00
can0 60B [8] 00 00 FF FF 00 00 00 00
can0 603 [8] 02 00 00 00 00 00 00 00
can0 601 [8] 00 00 00 00 00 00 00 00
```

Matching the base IDs on the digital dash:

-Press disconnect and enter the base addresses in decimal, then press connect to save

CAN I/O Extender base addresses:

Use: 1024 = 0x400 (ALL OTHER ECUs)

1536 = 0x600 (STANDALONE / FORD V8/BARRA / WRX)

For the RPM (shiftlight) base address:

Use: 1546 = 0x60A

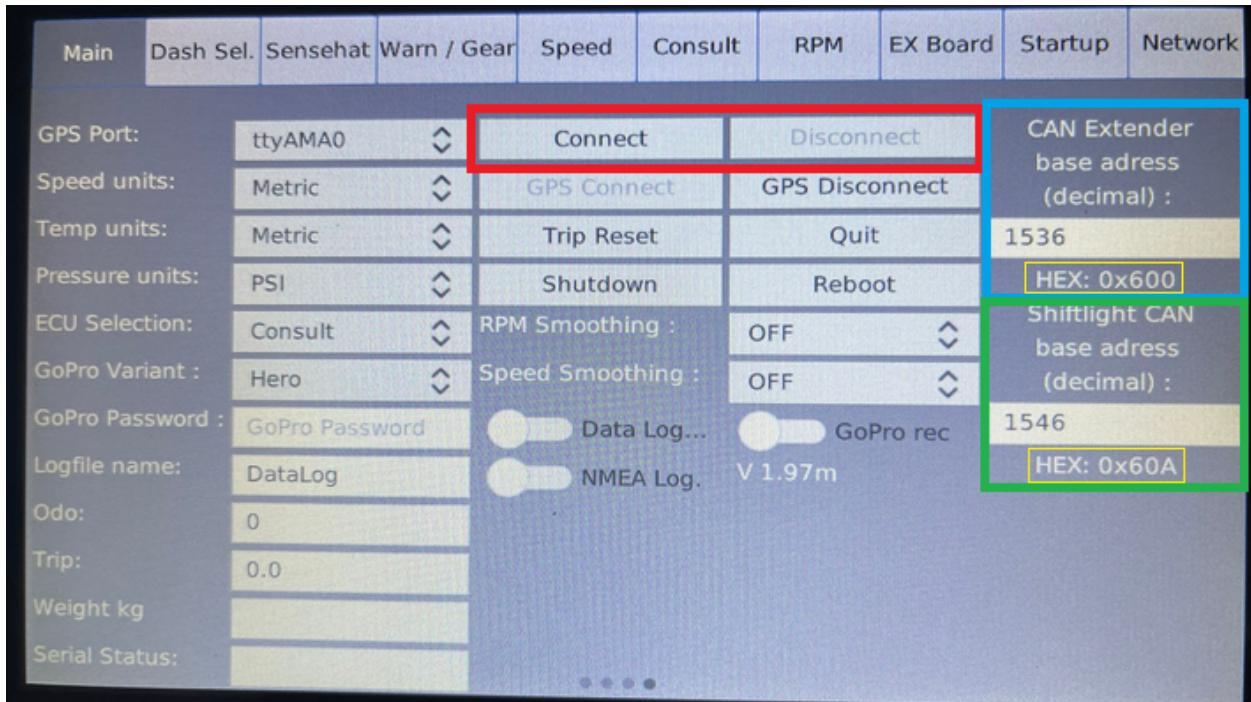

Section 4 - Analogue and Digital Input Wiring

35 PIN CONNECTOR B: Ground wires + digital & analog inputs

Plug the larger 35 pin connector into the CAN extender box (requires firm press!) and connect any required sensor grounds.

Pins 25, 26, 27 and 28 can be used for sensor grounds.

Pin 29 or 30 provide 5v power supply to a sensor when required.

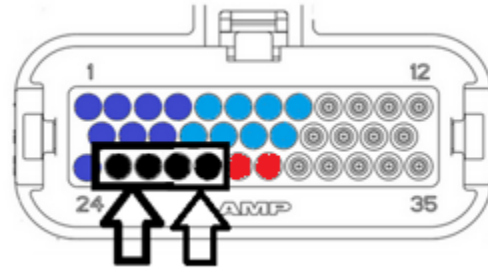

Sensor signal wires can be connected to the analog inputs. The left set of wires (pictured as the purple circles) is for **analog inputs**.

(Used for voltage and resistance based sensors)

For fuel tank level input use Analogue input 7 (features dampening).

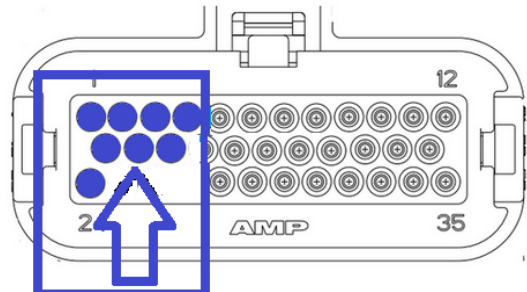

The middle set of wires (pictured as the blue circles) is for **digital inputs**.

(Used for indicators, lights, on/off signals)

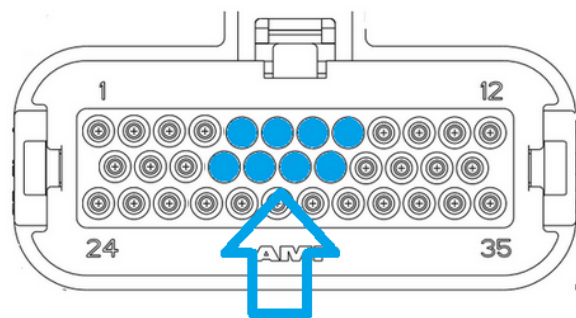

Pinout table: (pin numbers are located in the corners of the connector pictures)

Pin 1 : Analog input channel 1 Pin 2 : Analog input channel 3 Pin 3 : Analog input channel 5 Pin 4 : Analog input channel 7 (FUEL TANK)	Pin 5: Digital input channel 2 Pin 6: Digital input channel 4 Pin 7: Digital input channel 6 Pin 8: Digital input channel 8	Pin 13: Analog input channel 2 Pin 14: Analog input channel 4 Pin 15: Analog input channel 6
Pin 16: Digital input channel 1 (TACH) Pin 17: Digital input channel 3 Pin 18: Digital input channel 5 Pin 19: Digital input channel 7	Pin 24 : Analog input channel 0 Pins 25 - 26 : Ground Pins 27 - 28 : Ground Pins 29 - 30 : 5v Power supply	Pins 9 - 12 : Unused Pins 20 - 23: Unused Pins 31 - 35 : Unused

PLEASE NOTE: This information is provided as a general guide to CAN Bus wire colours only and colours may be subject to change without notice. Powertune Digital accepts no responsibility for damage or malfunction caused by incorrect wiring of its products to a vehicle. Any connection to a vehicle CAN Bus should be done by a trained automotive technician.

- Do not assume a red wire is power, always check the connector pinout to verify.
- Do not assume a wire that is NOT colored red does NOT carry power.
- Always trace the wires to the connector and verify against the connector pinout during installation to ensure you have the correct wire/pin location.
- Do not depend solely on colors to determine the correct wire to select.

There are 8 Digital inputs with a 3.5v - 12v switch point (This means at a voltage above 3.5V, this state will be ENABLED/ON) and 8 Analog inputs with a 0-5v range.

The first six (Channel 0-5) analogue inputs can be used for non-linear (resistance based) sensors (Eg. temperature sensors) whilst all 8 channels can be used for linear(voltage) sensors.

The CAN Extender only reads positively switched sources/sensors. It is not compatible with sensors switched to ground. Example, the temperature side of a Bosch Combo sensor is NOT supported due to it being switched to ground. Best practice is to always use 2-pin temperature sensors.

For **Analog** inputs, your Powertune Digital dash displays data on two gauge channels. Analog input 0 broadcasts a signal to gauge channels named "**ExAnalog-input 0**" and "**ExAnalogCalc0**" on your Powertune Digital dash. Whereby ExAnaloginput 0 will display the "**raw**" voltage reading, ExAnalogCalc 0 will display the "**computed**" value to make it human readable (eg PSI)

Each **Digital** input broadcasts to one corresponding gauge channel, for example digital input 7 broadcasts to the channel named "ExDigital-input 7". A value of 0 indicates OFF, a value of 1 indicates ON.

How to wire in Fuel Level

Wire a 240 ohm resistor between a 5v power supply and AN7 from CAN extender, along with the fuel sender (pictured below).

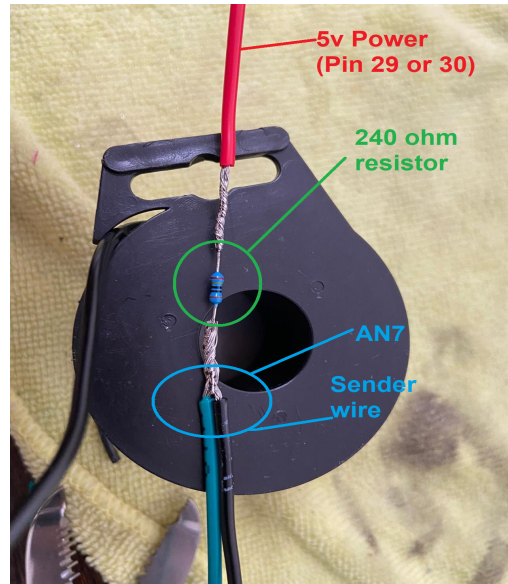

If the fuel sender is not grounded within the tank, for example it is grounded by the factory cluster which is being removed, the fuel level ground wire (also known as fuel level return wire) for the sender can be connected to one of the CAN extender sensor grounds.

Use the VOLTAGE DIVIDER in the following link to find the dash settings for the values at 0-5V.

EX BOARD SETTINGS Calculator: [LINK](#)

-Alternator Charge -

When you remove the factory cluster, on some vehicles, this can cause the alternator to not charge the battery, as the battery light has been removed. To solve this issue, you simply need to add some resistance to the circuit to “trick” the alternator. To do so, follow the below steps:

1. Locate your **battery light** wire (Sometimes called a **charge wire**) and your **12V/Ignition** wire.
2. With a resistor, such as a **5 watt resistor**, splice on one side of the resistor to the charge wire, and on the other side of the resistor, splice into the 12V/Ignition wire.
3. This will complete the circuit when the factory cluster is removed and add resistance, tricking the alternator to charge.

– How to wire in general Sensors –

When wiring **voltage** based (e.g. pressure sensors), a typical three pin pressure sensor will have dedicated pins for 5V power, ground and signal. Connect 5V power from the CAN extender to the power pin on the sensor, ground the grounding pin (use extender sensor ground if required), and finally connect an analog input from the extender to the signal pin on the sensor.

When wiring **ohms/resistance** based sensors (typically temperature sensors), a typical two pin temperature sensor will have a ground pin and signal pin. Connect one of the 5V power supplies from the IO extender to the ground pin on the sensor, and connect one of the analog inputs from the extender to the signal pin on the sensor.

Ensure to always double check your sensor pinout to ensure you connect the signal/power/ground from the extender to the correct pins on the sensor.

The below is an **example**:

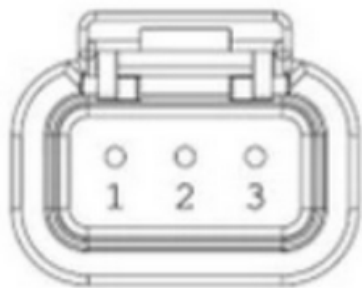

Example pinout for three pin voltage sensor:

1. **Sensor ground** (ground)
2. **Signal** (connect to analog input)
3. **Power** (connect to 5V)

Resistance Based Sensors



Section 5 - Wiring Check

Once all wiring is completed, turn on the vehicle ignition (engine can remain off) so your Digital Dash and CAN I/O Extender all receive power from the vehicle.

To check if you have wired in your sensors correctly, follow the below steps to see each sensor voltage:

1. Double tap a layout to open the menu.
2. Select **Import** and from the dropdown menu, select either of the following layouts: **"Analog inputs"** for your sensors or **"Digital inputs"** for your on/off lights.
3. Pressing the load button in the layout menu will import all 8 input channels at once. Inputs that do not have a sensor wired to them will not show any values.
4. Press Save so you can use the layout for reference if need be

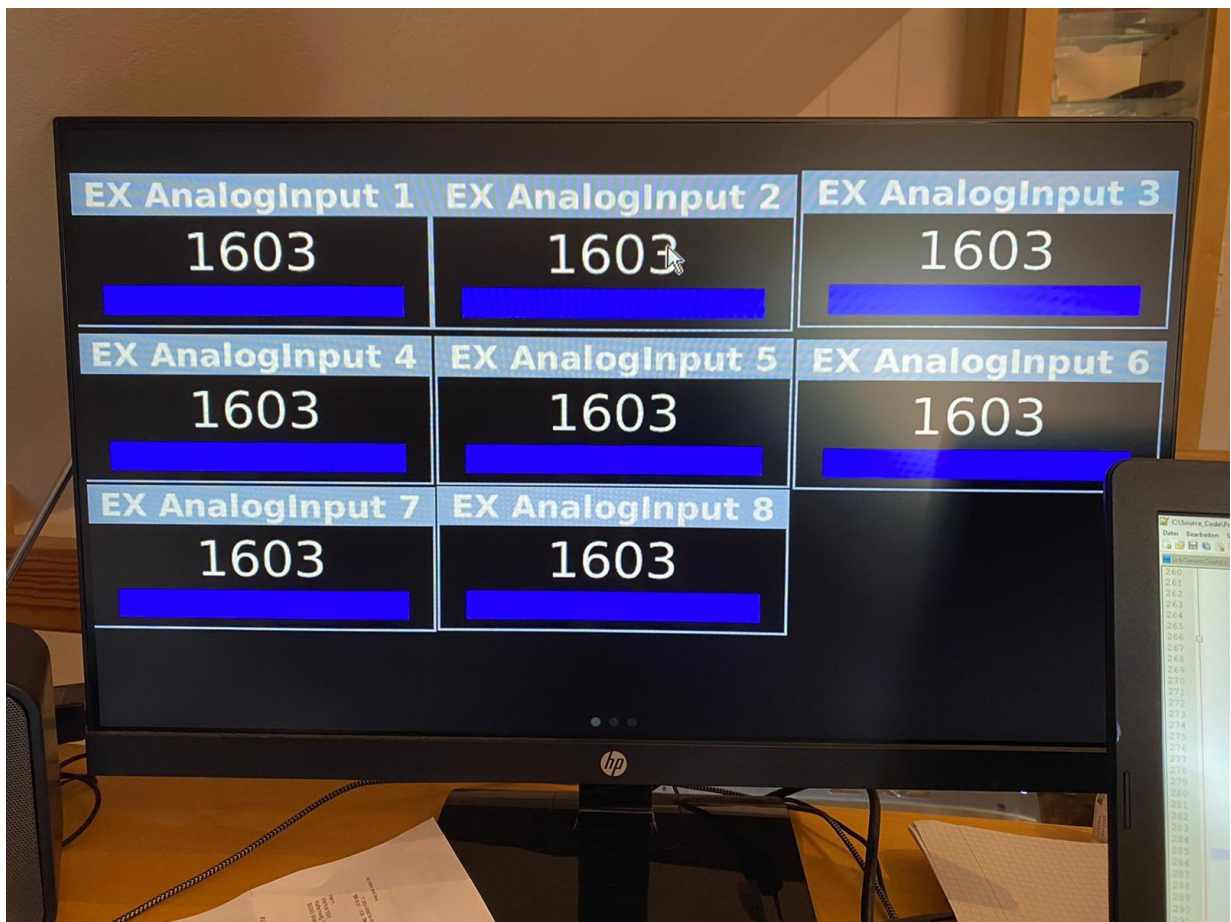

Section 6 - Sensor Calibration and Adding Channels to a Layout

Main	Dash Sel.	Sensehat	Warn / Gear	Speed	Analog	RPM	EX Board	Startup	Network			
Volt. divider jumpers												
EX AN	0	Val. @ 0V	Val. @ 5V	Temp. In	T1 (°C)	R1 (Ω)	T2 (°C)	R2 (Ω)	T3 (°C)	R3 (Ω)	100Ω	1KΩ J.
EX AN 0	0	19.04									<input checked="" type="checkbox"/>	<input checked="" type="checkbox"/>
EX AN 1	0	5	<input checked="" type="checkbox"/>	-20	67640	65	2589	150	309			
EX AN 2	0	5	<input checked="" type="checkbox"/>	-20	27256	60	662	150	41			
EX AN 3	16.25	46.25										
EX AN 4	0		<input checked="" type="checkbox"/>	-20	67640	65	2589	150	309			
EX AN 5	0	5										
EX AN 6	0	5										
EX AN 7	-40	240										
Ex AN 7 damping	400											
RPM CAN	<input checked="" type="checkbox"/>	RPMCAN Version	v2	Cylinders	8							

Now that our sensors are wired in, we can input their values into the **EX Board** Tab in the settings of the Digital Dash.

(Using a mouse and keyboard will make this step easier but it is not required)

In each channel, input the corresponding sensor calibration into the table, according to the documentation of the sensor manufacturer. For **Voltage** based sensors (such as Pressure Sensors), enter the value that should be displayed at 0V in the field **Val. @ 0v** and the value that should be displayed at 5V in the field **Val. @ 5V**

For **Temperature sensors**, which typically use a resistance, tick the **Temp. In** box for each channel required. Consult your sensor's datasheet, and identify the lowest, middle, and highest temperature (**T1**, **T2**, and **T3** respectively) in the sensor's range, and their corresponding resistance (**R1**, **R2**, and **R3** respectively). The input **NEEDS** to be in degrees Celsius for calibration, the gauge output will show in degrees Celsius or Fahrenheit, depending on the Temp units selection in the **Main Settings**.

The calculated values for each channel will be available in the corresponding datasource **ExAnalogCalc**, which is selected when adding gauges to our layout.

If your sensor ranges are not 0V - 5V (Such as 0.5V - 4.5V) use the RANGE CONVERTER tab in the below link to convert the range to 0V - 5V

Range Converter Calculator: [LINK](#)

Section 7 - Adding Channels to a Layout

Now that all our sensors are wired in, and have been calibrated, we can add them to a layout.

You can use an existing layout, or create your own. Steps on how to do this can be found here:

On an existing layout, for your **Analog Inputs**:

1. Double tap the screen to open the menu, then double tap on the selected gauge number to open the gauge menu. (You can click and drag the first menu if required)
2. Once the second menu is open, Click the **Channel** button, and scroll down the dropdown box until you reach **EX AnalogCALC 0-7**.
3. Select the required channel that you wish to display, and then click the **Use Datasource button**.
4. Close the menus and now your selected calculated channel data will appear.
5. Repeat steps 1-4 for all your other Analog Inputs

On the same layout for your **Digital Inputs**:

1. Double tap the screen to open the menu, select the **State Image** button. A coloured box will appear
2. Double tap the screen to open the menu again and then select the coloured box with the words **State Image**
3. A menu will appear, select the image when the light is off (e.g Left_Indicator_off.PNG) and when the light is on (e.g Left_Indicator.PNG)
4. Select the datasource that associates with the image from the drop down menu. The **EX Digital Inputs** are at the bottom, and are in numerical order.
5. Once selected, press apply, and test the **Digital Input**
6. Repeat steps 1-5 for all your other Digital Inputs