

# Tube Negro mate | 335.0588.180

FAMILY : **Campanas** | INSTALLATION TYPE : **Isla** | SERIE : **Tube** | MODEL : **FTU PLUS 3707 I BK** | FINISH : **Negro mate**

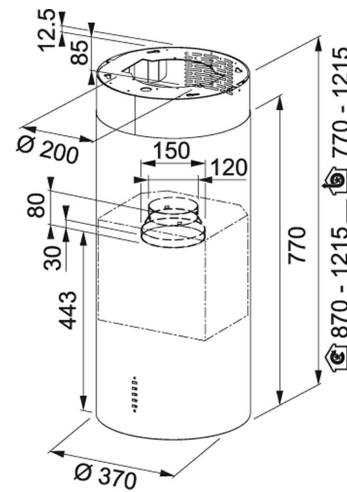

Campana de isla

## DATOS TÉCNICOS

Ancho	37,00 cm
Salida	Ø 150 mm
Iluminación	LEDS 2x1W
Filtros Carbón Activo	No incluido
Número de velocidades	3+int.
Aspiración en Int. (UNE EN-61591)	670-M3/H
Aspiración en Máx. (UNE EN-61591)	570 m3/h
Aspiración en Mín. (UNE EN-61591)	290 m3/h
Potencia Máx. (W)	270 W
Pot. sonora en Int. (UNE EN-60704-3)	70 dB(A)
Pot. Sonora en Máx. (UNE EN-60704-3)	66 dB(A)
Pot. Sonora en Mín. (UNE EN-60704-3)	52 dB(A)
Clase Energética	A
Tipo de Mandos	Pulsantes

## CARACTERÍSTICAS

☉ <sub>A</sub>	Lamp	3±	3
	Efficiency		Velocidades
	Class		+
	Hoods A		Intensiva
🔊 <sub>70dB</sub>	Maximum	🔊 <sub>A</sub>	Fan
	Noise		Efficiency
	Level 70		Class
	dB		Hoods A
🧴 <sub>B</sub>	Grease		
	Filter		
	Efficiency		
	Class		
	Hoods B		