

Rain Sensor



Model: TX14R
DC: 092817

Power

Insert 2- AA batteries into the rain sensor according to polarity.

1. Flip open both locking tabs on your rain sensor and lift off the funnel portion.
2. Pull up on the battery cover and remove.
3. Install 2-AA batteries according to polarity. Reposition the battery cover over the battery compartment, and firmly push down to lock it back into place
5. Remove cardboard and any tape around the rocker before use. These were used to protect the sensor from unwanted movement during shipping.
6. Place the funnel portion back over the sensor and re-secure the locking tabs.

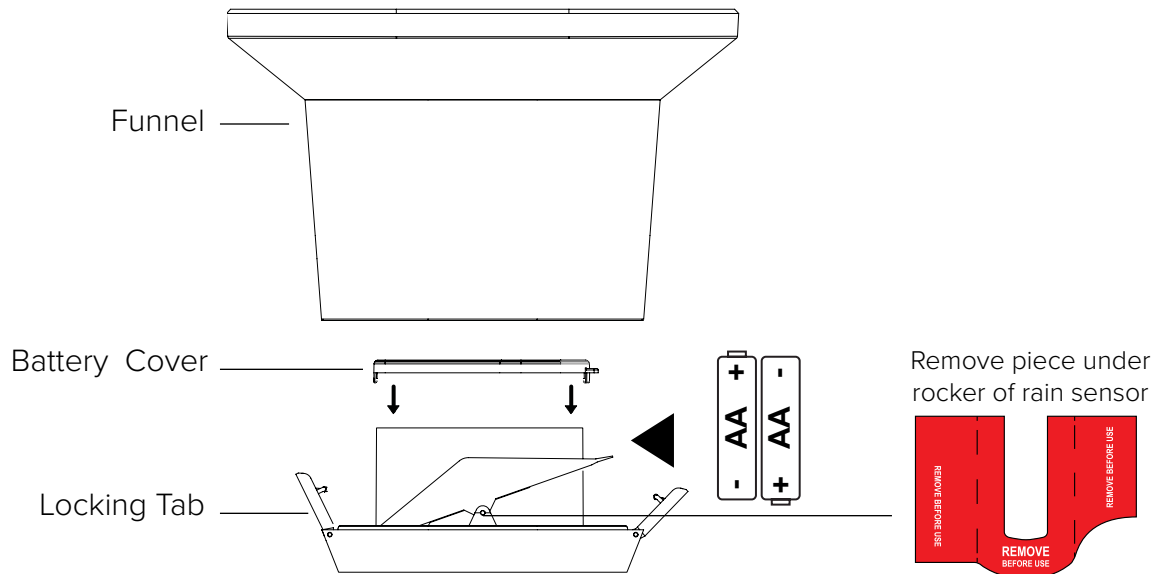

Position TX14R Rain Sensor



- Mount your rain sensor in an open area for a more accurate rain count.
- Placing the rain sensor on the ground provides the most accurate rainfall measurement as there is no wind shear. Unfortunately, since insects think of rain sensors as personal hotels, placing your sensor 3-6 feet above ground may deter the insects.
- This is a self-emptying sensor, but be sure your unit is not sitting in a depression that would prevent rain from draining out of the bottom
- Your rain sensor should be accessible to allow for periodic cleaning of leaves or other debris that may clog the funnel.
- Install the Rain sensor on a level platform that is stationary and has a direct line of sight to your station.
- Insert mounting screws through the holes in the base of the rain sensor. Do not over tighten.
- Use the bubble level inside your sensor to be sure it is level.
- Avoid other wireless rain sensors as this can cause inaccuracy due to signal interference.
- The maximum wireless transmission range to the rain station is over 300 feet (91 meters) in open air, not including walls or floors.
- For video instruction, please visit: http://bit.ly/Rain_SensorMounting

Clean Rain Sensor

1. Press the Locking Tabs on each end and lift off the funnel.
2. Gently remove debris or insects inside the rain sensor.
3. Clear debris from drain vents.
4. Clear debris from the rain funnel itself.
5. Reinstall the rain funnel.

Note: Do not oil the rain sensor.

Let's Be Social!

JOIN THE CONVERSATION

Follow us on our social media outlets for the latest promotions, product support, and awesome giveaways.



Help Us, Help You!

If you have ideas for features or support solutions you'd like to see us make, please let us know! We truly want to make owning a La Crosse Technology product not only a practical experience, but also a fun one. So email us at: store@lacrossetechnology.com

Specifications

Rain Range: 0-393.6 inches (0-9999mm) over 300 feet open air 433MHz RF

Batteries: 2-AA, IEC, LR6 batteries (not included)

Battery Life: over 12 months with reputable batteries.

Dimensions: 7.14" L x 3.43" W x 4.94" H (18.13cm L x 8.72cm W x 12.54cm H)

Warranty and Support

La Crosse Technology, Ltd. provides a 1-year limited time warranty (from date of purchase) on this product relating to manufacturing defects in materials & workmanship. Before returning a product, please contact our friendly customer support with questions or visit our online help:

Phone: 1-608-782-1610

Online Product Support and Registration: www.lacrossetechnology.com/support

FCC Statement

This equipment has been tested and found to comply with the limits for a Class B digital device, pursuant to part 15 of the FCC Rules. These limits are designed to provide reasonable protection against harmful interference in a residential installation. This equipment generates, uses and can radiate radio frequency energy and, if not installed and used in accordance with the instructions, may cause harmful interference to radio communications. However, there is no guarantee that interference will not occur in a particular installation.

If this equipment does cause harmful interference to radio or television reception, which can be determined by turning the equipment off and on, the user is encouraged to try to correct the interference by one or more of the following measures:

- Reorient or relocate the receiving antenna.
- Increase the separation between the equipment and receiver.
- Connect the equipment into an outlet on a circuit different from that to which the receiver is connected.
- Consult the dealer or an experienced radio/TV technician for help.

This device must not be co-located or operating in conjunction with any other antenna or transmitter.

Operation is subject to the following two conditions:

- (1) This device may not cause harmful interference, and
- (2) This device must accept any interference received, including interference that may cause undesired operation.

Caution!

The manufacturer is not responsible for any radio or TV interference caused by unauthorized changes or modifications to this equipment. Such changes or modifications could void the user authority to operate the equipment.

This equipment must be installed and operated in accordance with provided instructions and the antenna(s) used for this transmitter must be installed to provide a separation distance of at least 20 cm from all persons and must not be co-located or operating in conjunction with any other antenna or transmitter

All rights reserved. This manual may not be reproduced in any form, even in part, or duplicated or processed using electronic, mechanical or chemical process without the written permission of the publisher. This booklet may contain errors or misprints. The information it contains is regularly checked and corrections are included in subsequent editions. We disclaim any responsibility for any technical error or printing error, or their consequences.

All trademarks and patents are recognized.