

Wind Speed | Temperature | Humidity

Features

- Wind speed
- Replaceable wind cups
- Temperature | Humidity
- Updates every 30 seconds
- Red LED flashes with each transmission

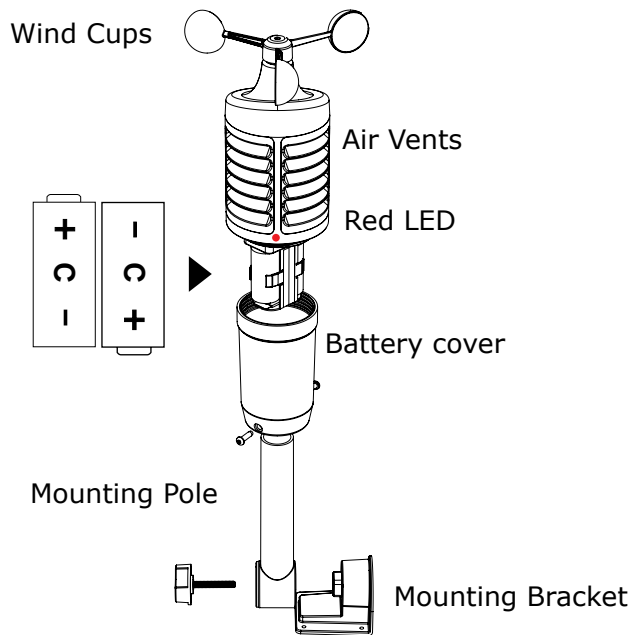

Power

1. Twist battery cover left to remove from sensor.
2. Insert two "C" batteries into the TX141Wv2 sensor

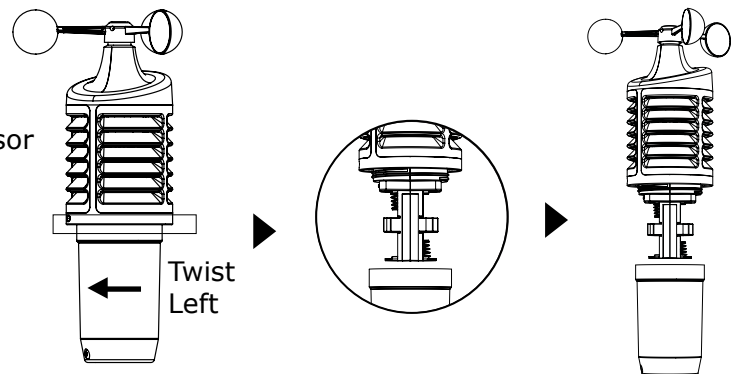

Model: TX141Wv2
DC: 030817

Replace Wind Cups

1. Loosen the screw on side of cups
2. Remove cups
3. Install new cups
4. Tighten screw on flat side of stem

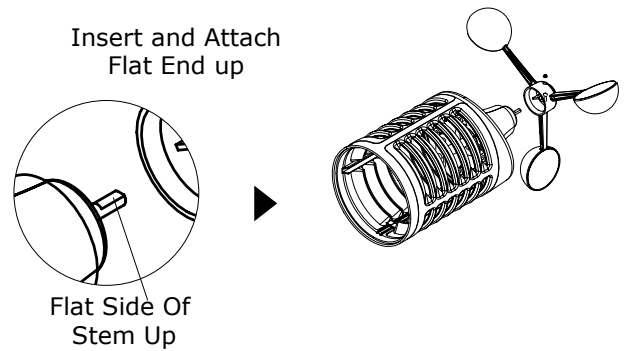

Position Wind Sensor

- For the most accurate wind speed readings, mount the TX141Wv2 sensor as the highest object for 50 feet in all directions.
- Cups should be on the top of the sensor. Mount vertically.
- The maximum wireless transmission range to the wind station is over 330 feet (100 meters) in open air, not including walls or trees.

1. Insert mounting pole into sensor.
2. Tighten screws
3. Insert bottom of pole into mounting bracket
4. Tighten knob to secure
5. Use screws through the bottom of the mounting bracket to attach.
6. The sensor can be mounted from the bottom or side.

Alternatively:

1. Insert your own mounting pole into the sensor.
2. Tighten screws
3. Mounting bracket would not be used.

Note: Do not attempt to insert a pole into the hollow back of the mounting bracket.

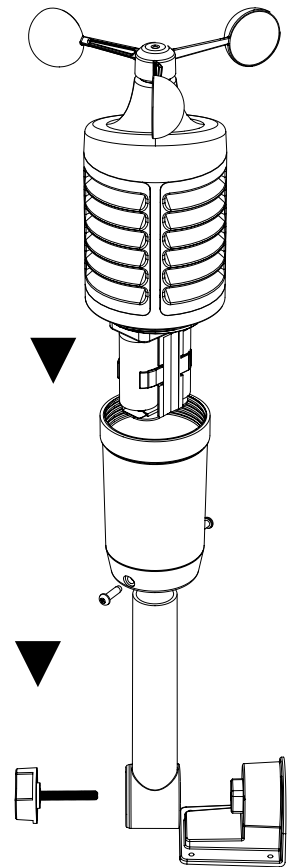

Specifications

- Wind Speed Range: 0 - 99 mph (0-159 kmh)
- Temperature Range: -40°F to 140°F (-40°C to 60°C)
- Humidity Range: 10% - 99% (RH)
- Transmission Range: 330 ft (100 m) RF 433MHz open air
- Batteries: 2-C, IEC, LR14 batteries (not included)
- Battery Life: over 24 months with reputable batteries
- Dimensions: 18.57" H x 7.10" W x 7.10" D
(471.68 x 180.34 x 180.34 mm)

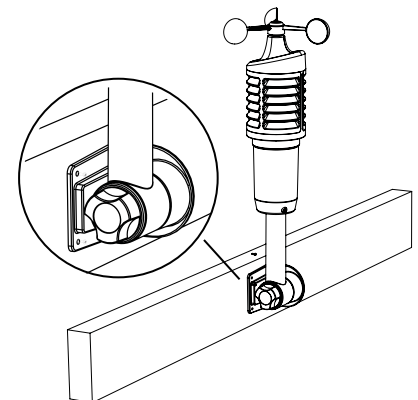

Warranty and Support

La Crosse Technology, Ltd. provides a 1-year limited time warranty (from date of purchase) on this product relating to manufacturing defects in materials & workmanship.

Before returning a product, please contact our friendly customer support or visit our online help:

Phone: 1-608-782-1610

Online: www.lacrosstechnology.com/support/

View full warranty details online at:

www.lacrosstechnology.com/warranty_info.pdf

FCC Statement

This equipment has been tested and found to comply with the limits for a Class B digital device, pursuant to part 15 of the FCC Rules. These limits are designed to provide reasonable protection against harmful interference in a residential installation. This equipment generates, uses and can radiate radio frequency energy and, if not installed and used in accordance with the instructions, may cause harmful interference to radio communications. However, there is no guarantee that interference will not occur in a particular installation.

If this equipment does cause harmful interference to radio or television reception, which can be determined by turning the equipment off and on, the user is encouraged to try to correct the interference by one or more of the following measures:

- Reorient or relocate the receiving antenna.
- Increase the separation between the equipment and receiver.
- Connect the equipment into an outlet on a circuit different from that to which the receiver is connected.
- Consult the dealer or an experienced radio/TV technician for help.

This device must not be co-located or operating in conjunction with any other antenna or transmitter.

Operation is subject to the following two conditions:

- (1) This device may not cause harmful interference, and
- (2) This device must accept any interference received, including interference that may cause undesired operation.

Caution!

The manufacturer is not responsible for any radio or TV interference caused by unauthorized changes or modifications to this equipment. Such changes or modifications could void the user authority to operate the equipment.

This equipment must be installed and operated in accordance with provided instructions and the antenna(s) used for this transmitter must be installed to provide a separation distance of at least 20 cm from all persons and must not be co-located or operating in conjunction with any other antenna or transmitter

All rights reserved. This manual may not be reproduced in any form, even in part, or duplicated or processed using electronic, mechanical or chemical process without the written permission of the publisher. This booklet may contain errors or misprints. The information it contains is regularly checked and corrections are included in subsequent editions. We disclaim any responsibility for any technical error or printing error, or their consequences.

All trademarks and patents are recognized.