

LA CROSSE[®]
TECHNOLOGY

CYCLONE PRO SENSOR



LTV-WSDR1

Initial Setup

Installing the Wind Cups (if needed)



1. Remove the Cyclone Pro Sensor, Wind Cups, and Mini Screwdriver from the package. Take note of the flat edges located on the head of the Sensor and underside of the Wind Cups.

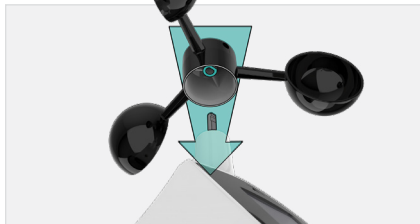

2. Align the flat edges and place the Wind Cups on top of the Cyclone Pro Sensor.

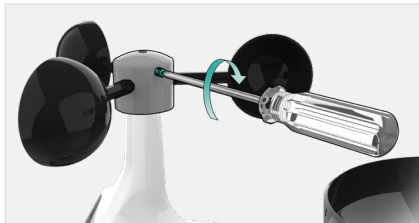

3. Carefully tighten the screw on the side of the cups using the Mini Screwdriver. The screw should tighten into the flat edge of the post.

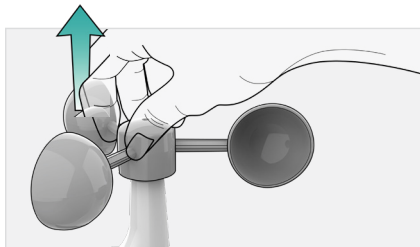

4. When the screw is tight, gently pull up on the cups to ensure they are secure. If they pull off, start again with step two.

Powerup



Install 3-AA Batteries

Insert 3-AA batteries into the bottom of the Cyclone Pro Sensor according to polarity.

Adding Your Sensor to the La Crosse View App

1. Open your La Crosse View app. On the Main Menu, scroll to **ADD/EDIT** and select **DEVICES**.
2. On the Devices page, select the **ADD DEVICE** or **PLUS (+)** button.
3. Scan the Barcode on your Sensor or type in the Device ID manually.
4. Confirm the sensor image and Device ID and add a Device Name and Location Name. Select **DONE**.

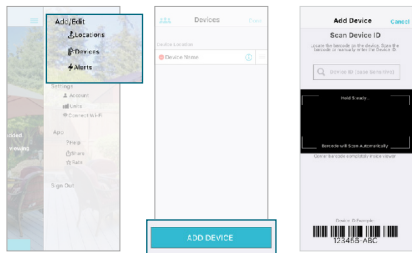

Bottom of Cyclone Sensor ▶

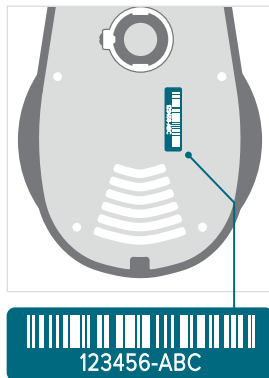

Sensor Placement & Mounting



For Accurate Cyclone Sensor Measurements

- Use the built-in Bubble Level to ensure the Cyclone Pro Sensor (especially the rain gauge) is mounted level.
- Ensure the Solar Panel is facing to the South. This helps optimize battery life and transmit correct wind direction data.
- Ideally, the Cyclone Pro Sensor should be mounted on the tallest object in your area. Avoid positioning the sensor parallel or below eaves, roof lines, trees, or other objects that may obstruct wind and rain readings.
- Make sure all the screws on the Mounting Bracket, Wind Cups, Wind Vane, and Battery Compartment are securely fastened.
- The Cyclone Pro Sensor should be mounted with the Wind Cups on the top.

Basic Installation

Fence posts, poles, decks, and mailboxes are common mounting options due to their convenience. Many users prefer these types of locations as the data they provides is accurate from their ground level. However, because the wind in these spots is often affected by obstructions, the readings may differ when compared to local reporting stations.

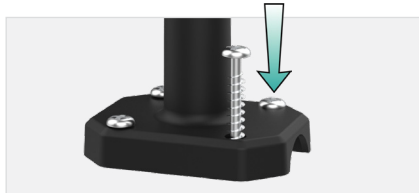

1. Mount the Mast to a flat surface with the four provided screws.



2. Place the Cyclone Pro Sensor on top of the Mast. Ensure the Solar Panel is facing south.

Sensor Placement & Mounting



3. Check the integrated Bubble Level or use your own across the Rain Funnel to ensure the sensor is level.



4. Secure the Cyclone Sensor to the Mast by tightening the screws on the side. After screws are tightened, double check the sensor has remained level through the installation process.

Flexible Installation



Install the Hand Screw to the bracket, then Secure the Cyclone Sensor to the Mast by tightening the screws on the side.

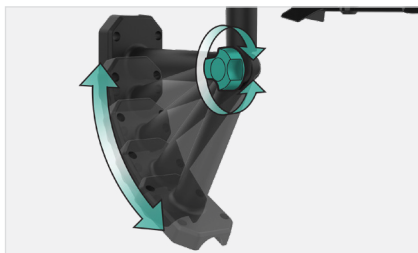

This configuration allows you to attach the sensor to angled locations and easily make adjustments to ensure the Mast and Sensor are level.

Cyclone Pro Sensor Mounting

Advanced Installation

Some advanced installation options include tripods, wall mounts, chimney mounts, and many others. Any of these can be combined with U-bolts for attachment onto a tall cylindrical conduit using our Adjustable Base. These options will require additional equipment and possibly professional help for best results.



Freestanding Pole Setup

1" Maximum Outside Pole Diameter



Tripod Setup Example

1" Maximum Outside Pole Diameter

Cleaning the Rain Sensor

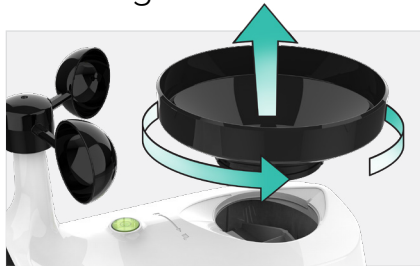

1. Remove the Rain Funnel by firmly twisting the funnel counter-clockwise and lifting up.

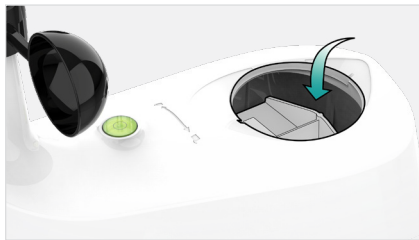

2. Clear any leaves, insects, or other debris to allow the Rain Tipper to rock freely. Check and clear the Drainage Holes located on the underside of the sensor.

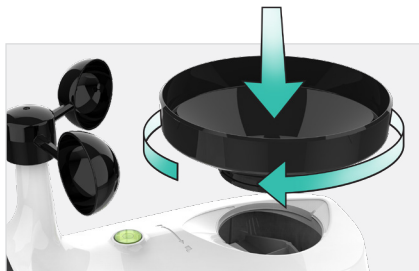

3. After cleaning, re-install the Rain Funnel by placing it back into the sensor and twisting clockwise until secure.

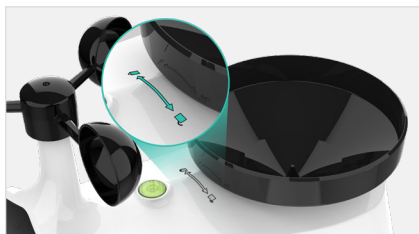

4. You should feel the funnel lock into place when one of the arrows lines up with the center of the Lock/Unlock Line.

Tip: Remove the Cyclone Pro Sensor's batteries before cleaning to avoid accidental rain readings.

Specifications

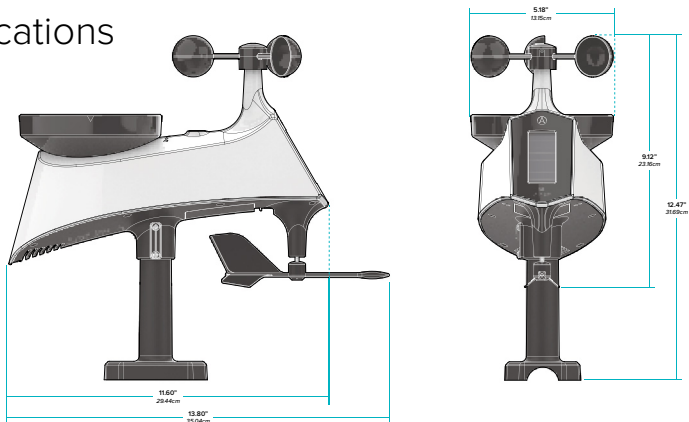

CYCLONE PRO SENSOR (LTV-WSDR1)

- **Wind Speed Range:** 0 to 111 mph
(0 to 178 kph)
- **Rainfall Range:** 0 to 393.6 Inches
(0 to 9999 mm)
- **Transmission Range:** 400 feet 915MHz
(121 meters) open air
- **Power Requirements:** 3 "AA" Batteries
(not included)
- **Update Interval:** Every 31 Seconds

Stay in Touch

Ask questions, watch setup videos, and provide feedback on our social media outlets.



Follow La Crosse Technology on Facebook, Instagram, YouTube, and Twitter.

We're here to help.

Use the links below to find additional resources or reach out to our staff directly. Representatives are available Monday-Friday, 8am-6pm CST

Online: bit.ly/contact_techsupport

Phone: 1.844.200.8752

Warranty

La Crosse Technology, Ltd. provides a 1-year limited time warranty (from date of purchase) on this product, relating to manufacturing defects in materials and workmanship.

For full warranty details, visit:

www.lacrossetechnology.com/pages/warranty

La Crosse Technology, Ltd.

2830 S. 26th Street, La Crosse, Wisconsin 54601

California Residents

⚠ CA WARNING: This product can expose you to chemicals including acrylonitrile, butadiene, and styrene, which are known to the State of California to cause cancer and birth defects or other reproductive harm. For more information, go to: www.P65Warnings.ca.gov

Battery Replacement

Battery Replacement Instructions

When batteries of different brand or type are used together, or new and old batteries are used together, some batteries may be over-discharged due to a difference of voltage or capacity. This can result in venting, leakage, and rupture and may cause personal injury.

- Always purchase the correct size and grade of battery most suitable for the intended use.
- Always replace the whole set of batteries at one time, taking care not to mix old and new ones, or batteries of different types.
- Clean the battery contacts and also those of the device prior to battery installation.
- Ensure the batteries are installed correctly with regard to polarity (+ and -).
- Remove batteries from product during periods of non-use. Battery leakage can cause corrosion and damage to this product.
- Remove used batteries promptly.
- For recycling and disposal of batteries, and to protect the environment, please check the internet or your local phone directory for local recycling centers and/or follow local government regulations.

FCC Statement

This equipment has been tested and found to comply with the limits for a Class B digital device, pursuant to part 15 of the FCC Rules. These limits are designed to provide reasonable protection against harmful interference in a residential installation.

This equipment generates, uses and can radiate radio frequency energy and, if not installed and used in accordance with the instructions, may cause harmful interference to radio communications. However, there is no guarantee that interference will not occur in a particular installation. If this equipment does cause harmful interference to radio or television reception, which can be determined by turning the equipment off and on, the user is encouraged to try to correct the interference by one or more of the following measures:

- Reorient or relocate the receiving antenna.
- Connect the equipment into an outlet on a circuit different from that to which the receiver is connected.
- Increase the separation between the equipment and receiver.
- Consult the dealer or an experienced radio/TV technician for help.

FCC Radiation Exposure Statement

This device complies with FCC radiation exposure limits set forth for an uncontrolled environment and it also complies with Part 15 of the FCC RF Rules. This equipment must be installed and operated in accordance with provided instructions and the antenna(s) used for this transmitter must be installed to provide a separation distance of at least 20 cm from all persons and must not be co-located or operating in conjunction with any other antenna or transmitter. End-users and installers must be provided with antenna installation instructions and consider removing the no-collocation statement.

This device complies with Part 15 of the FCC Rules.

Operation is subject to the following two conditions:

- (1) This device may not cause harmful interference, and
- (2) This device must accept any interference received, including interference that may cause undesired operation.

Caution: Any changes or modifications not expressly approved by the party responsible for compliance could void the user's authority to operate the equipment.