

# ***F*ORCE 15K**



## **USER MANUAL - V1**

# Disclaimer

Before utilizing this product, carefully peruse this user manual to ensure a comprehensive understanding of the product and its proper usage. Retain this manual for future reference after thorough reading. Failure to adhere to the guidelines outlined in this manual may result in severe injury to yourself or others, as well as potential product damage and property loss. By using this product, you acknowledge and accept all terms and content presented in this document.

**Mammoth RE** disclaims any responsibility for losses incurred due to the user's non-compliance with the guidelines provided in this user manual.

In accordance with applicable laws and regulations, Mammoth RE retains the right to the ultimate interpretation of this document and all associated materials related to this product. This document is subject to modifications (updates, revisions, or termination) without prior notification. For the latest product information, please refer to Mammoth RE official website.

 **WARNING:** Before installing or operating battery, make sure to review all safety guidelines, warnings, and precautions.

# Table of Contents

|           |                               |           |
|-----------|-------------------------------|-----------|
| <b>1.</b> | <b>Product Introduction</b>   | <b>6</b>  |
| <b>2.</b> | <b>Product Specifications</b> | <b>7</b>  |
|           | Specifications                | <b>7</b>  |
|           | Weight & Dimensions           | <b>8</b>  |
| <b>3.</b> | <b>Product Overview</b>       | <b>9</b>  |
|           | What's Included               | <b>9</b>  |
|           | Hardware Parts                | <b>10</b> |
|           | Internal Functions            | <b>13</b> |
| <b>4.</b> | <b>Connection Overview</b>    | <b>14</b> |
|           | PV Wiring Connection          | <b>14</b> |
|           | Quad Kit                      |           |
|           | Hex Kit                       |           |
|           | Platinum Kit                  |           |
|           | Schematic Diagram             | <b>18</b> |
|           | AC INPUT and AC OUTPUT        |           |
| <b>5.</b> | <b>Installation</b>           | <b>20</b> |
|           | Transportation                | <b>20</b> |

# Table of Contents

|                           |           |
|---------------------------|-----------|
| Choosing a Location       | <b>20</b> |
| Accessories               | <b>22</b> |
| Screen Menu               | <b>23</b> |
| LCD Screen                | <b>24</b> |
| Screen Display and Labels |           |
| Password                  |           |
| System Configuration      | <b>25</b> |
| System Parameters         |           |
| Output Voltage            |           |
| Output Frequency          |           |
| Solar Charging Current    |           |
| AC Input Range            |           |
| Priority                  |           |
| Battery Parameters        |           |

# Table of Contents

|   |           |
|---|-----------|
| General                                     | <b>31</b> |
| Time  |           |
| LCD Backlight                               |           |
| AC System Status                            |           |
| PV System Status                            |           |
| Charging Status                             |           |
| Battery Status                              |           |
| <b>6. Mobile Application Guide</b>          | <b>34</b> |
| <b>7. Warranty and Returns Information</b>  | <b>44</b> |
| <b>8. Warnings and Precautions</b>          | <b>45</b> |
| <b>9. Storage Information</b>               | <b>46</b> |
| <b>10. Frequently Asked Questions (FAQ)</b> | <b>47</b> |

# Product Introduction

The Force 15K takes everything there is to love about power stations and obliterated the issues: limited capacity, restrained power output, and unnecessary complexity. Unlike other units that claim to power your entire house with one unit but fall short in reality, the FORCE 15K is here to close that gap.

With a whopping 15,000Wh lithium battery, 8,000W 120/240V Inverter and up to 4,000W of Solar Input - The Force 15K gives you all the power you need.



## 2 Product Specifications

### 2.1 Specifications

| DESCRIPTION   | SPECIFICATION   |
|---|---|
| MODEL #   | FORCE 15K 0815-48   |
| INVERTER POWER (KW)                                   | 8kW   |
| BATTERY CAPACITY (KWh)                                | 15kWh   |
| DIMENSION   | L:620mm / W: 380mm / H:1000mm<br>L:24.4in / W: 15in / H:39.4in          |
| WEIGHT  | 179kg / 395 lbs   |
| PV IN CONNECTOR:                                      | BE175 to MC4  |
| PV INPUT VOLTAGE:                                     | 90VDC-230VDC (Open Circuit Voltage)                                     |
| PV INPUT MAX CURRENT:                                 | 80 Amps (4.5KW)   |
| PV CHARGING VOLTAGE:                                  | < 83VDC   |
| DC PORT INPUT VOLTAGE RANGE<br>(FOR BATTERY PARALLEL) |   |
| AC OUTPUT BREAKER CAPACITY                            |   |
| AC INPUT BREAKER CAPACITY                             | 63 Amps   |
| AC INPUT VOLTAGE RANGE:                               | 160VAC to 260VAC (UPS Mode)<br>(2 Hot Wire , 1 Neutral Wire , 1 Ground) |
| AC INPUT CONNECTOR (ON THE SIDE)                      | NEMA SS2-50P<br>(120VAC/240VAC , 50Amp)                                 |
| AC OUTPUT RECEPTACLE (ON THE SIDE)                    | NEMA 14-50R (120VAC/240VAC , 50Amp)                                     |
| AC OUTPUT RECEPTACLE<br>(ON FRONT PANEL)              | 4 x 120V Receptacle , 1x L14-30R<br>(120VAC/240VAC , 30Amp)             |
| USB PORT  | USB-C / USB   |
| COMMUNICATION PORT                                    | 2 x RS485,<br>1 x Generator Kick Off Port , WiFi                        |

## 2 Product Specifications

### 2.2 Weight and Dimensions

# FORCE 15K ESS

**10** **YEAR**  
**WARRANTY**

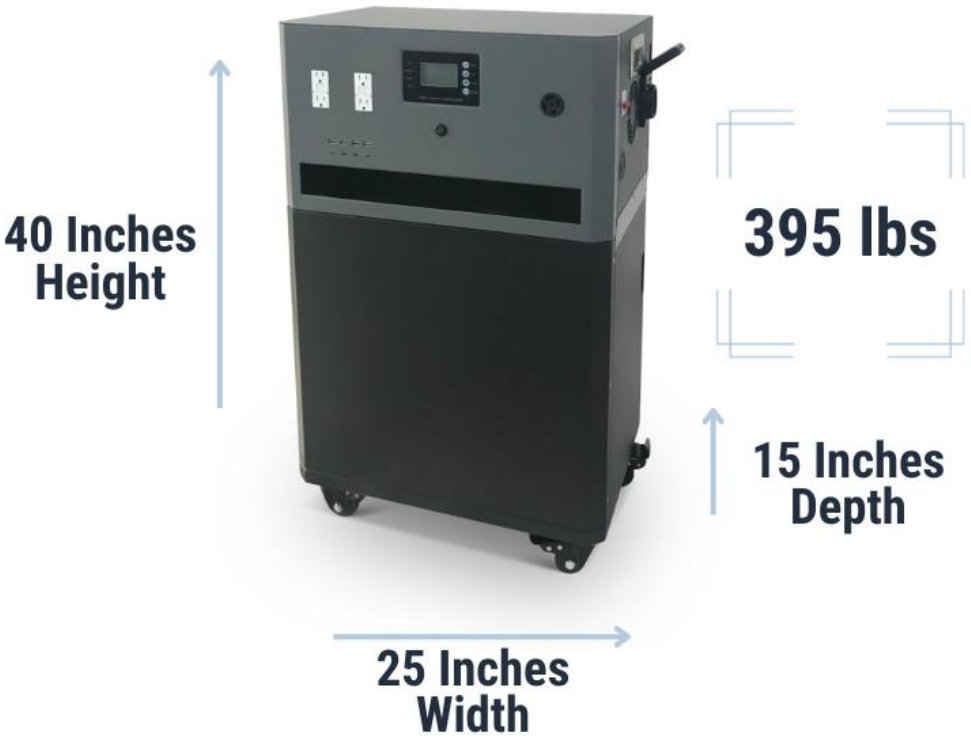



### 3 Product Overview

#### 3.1 What's Included?



**AC Wall Charger**



**NEMA 14-50R 240V Cable**



**Solar Panel Connector Cables**

## 3 Product Overview

### 3.2 Hardware Parts

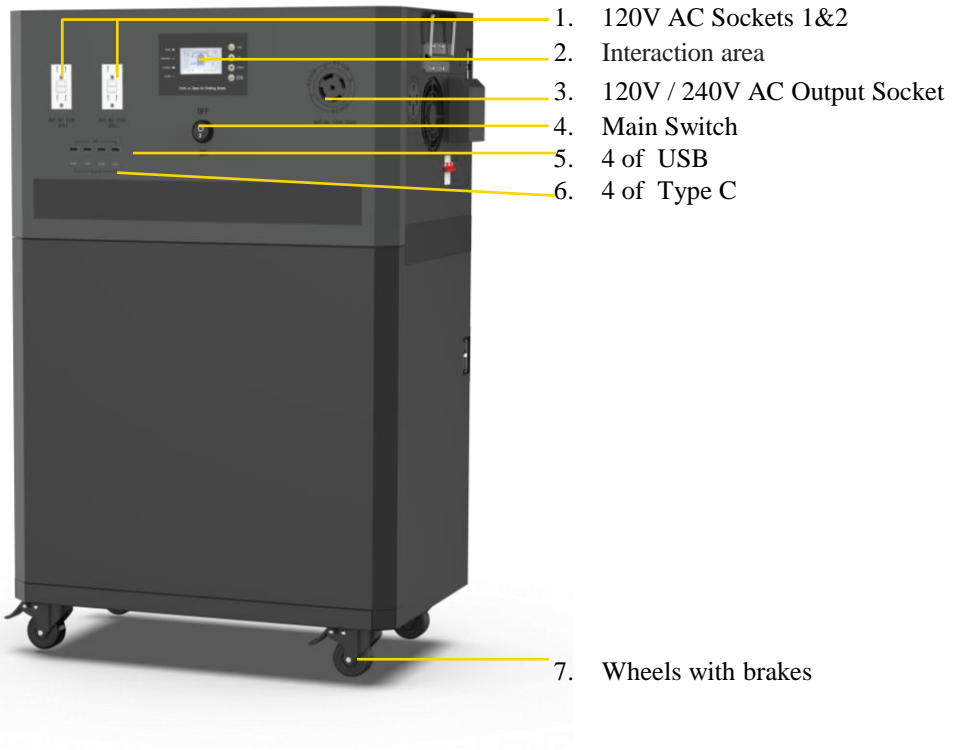

#### Descriptions:

1. Standard socket providing 110V to 120V power.
2. The area for getting battery information and performing settings. For detailed information, please refer to Section 4;
3. It's a Twist Lock socket used for providing 120V / 240V power.
4. This is the main battery switch. When it is turned off, it cuts off all power supply. However, if there is AC input, the battery will be in a bypass state. This means that the battery will still provide AC power from the sockets, but it will neither charge nor power itself.
5. These are 360-degree rotating wheels, with the front two wheels equipped with manual brakes.

## 3 Product Overview

### 3.2 Hardware Parts



1. AC Out (Max 50A)(NEMA14-50R) outlet
2. Wi-Fi
3. PV Input (90V-230V DC)
4. AC Input 120V/240V (SS2-50P) outlet
5. Breaker for AC In (Max 50A)
6. Ground
7. DC Input

#### Description:

1. This 50A Embedded Ground Blade Power Outlet (NEMA14-50R) provides 120 or 240V AC power.
2. Wi-Fi antenna used to enhance the signal and the stability of the connection.
3. BE175A connector used to connect to solar
4. Twist Lock Outlet (SS2-50P) used to charge the Force 15K from the grid.
5. Safety control of the AC input; Force 15K is completely disconnected from the grid before turning on the breaker, preventing AC charging and bypassing functionality.
6. Ground wire screw hole.
7. DC Input

### 3 Product Overview

#### 3.2 Hardware Parts



It is a communication port for interacting with the Walrus's BMS (Battery Management System).

# 3 Product Overview

## 3.3 Internal Functions

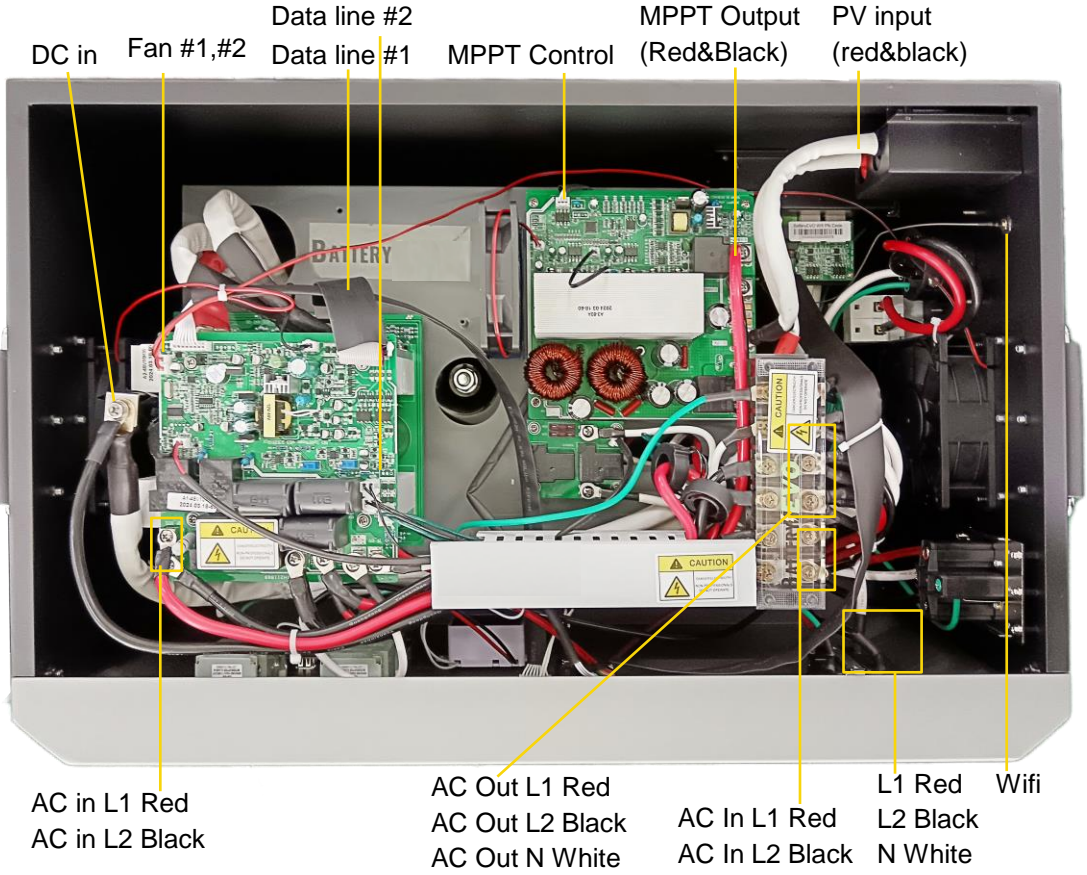

## 4 Connection Overview

### 4.1 PV Wiring

#### Connection:

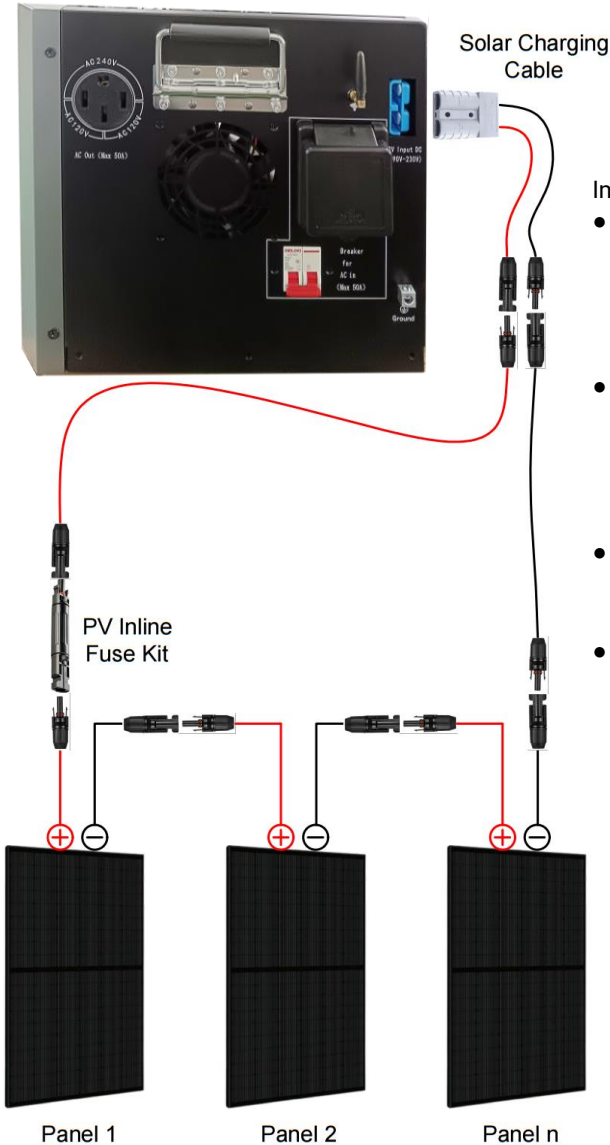

#### Important Notes:

- The output wires from solar panels typically come in black color. It is crucial to ensure a proper connection by matching the correct polarities.
- Positive wire of the PV module is the Male Connector. You can check the markings on the connector itself to ensure proper connection.
- PV input should not exceed 5 pcs of 400W panels connected in series. (shown as "n")
- Use RED extension cable for positive connection and BLACK for negative connection to avoid confusion. Check the diagrams for visualization.

## 4 Connection Overview

### 4.1.1 Custom Kits Wiring Setup: QUAD KIT (4 Series, 1 String)

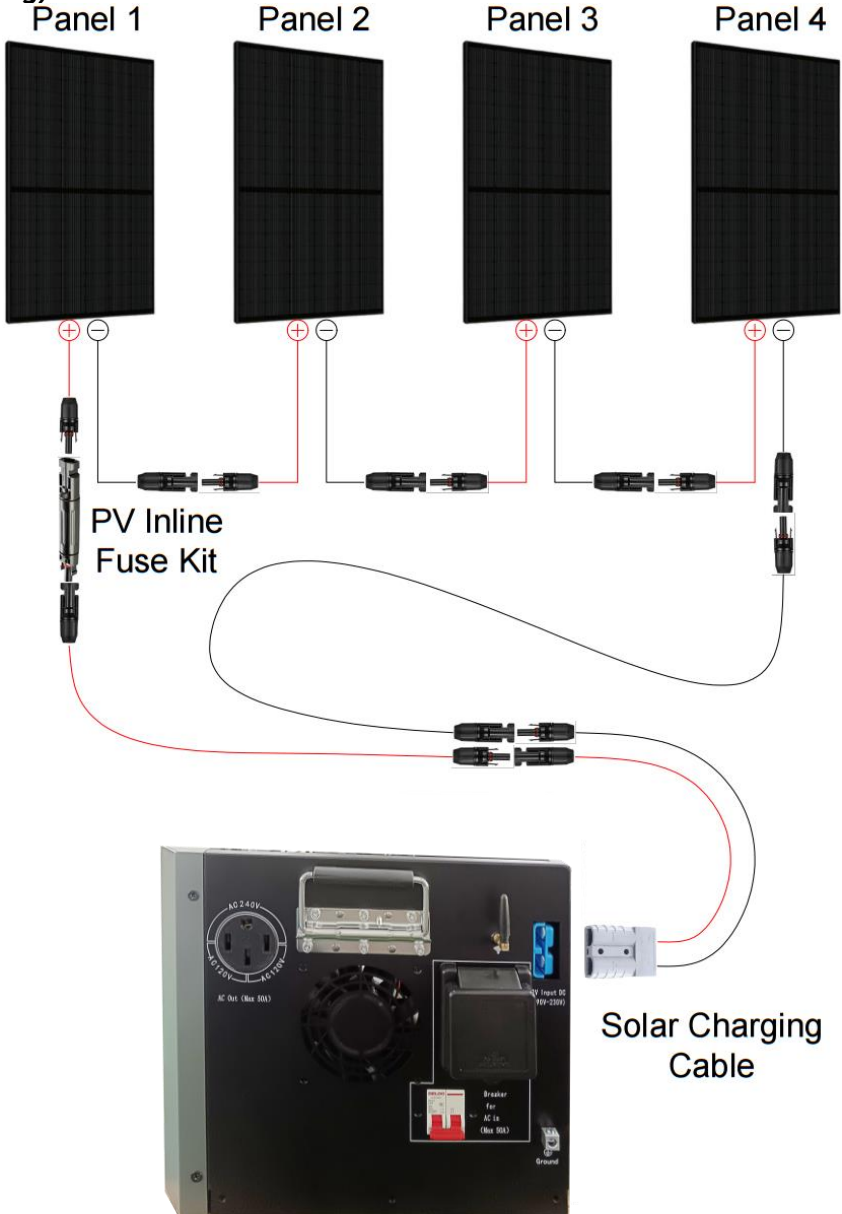

## 4 Connection Overview

### 4.1.2 Custom Kits Wiring Setup: HEX KIT (3 Series, 2 Parallel)

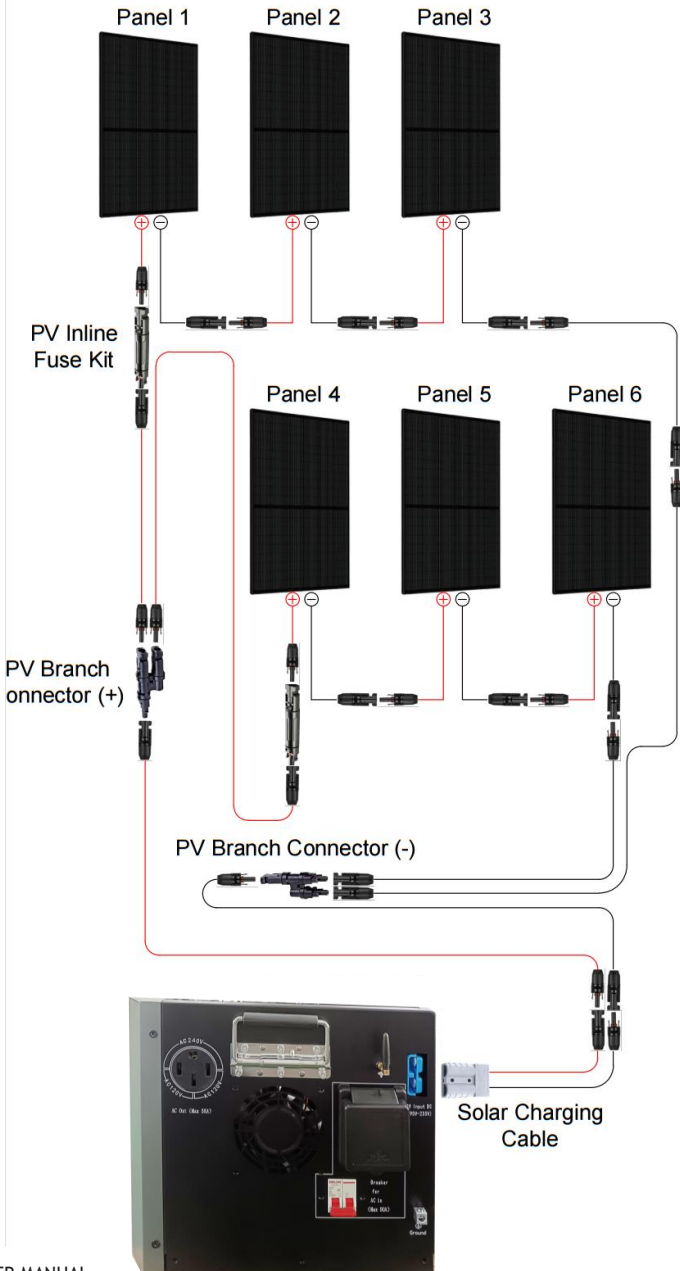



## 4 Connection Overview

### 4.1.3 Custom Kits Wiring Setup: PLATINUM KIT (5 Series, 2 Parallel)

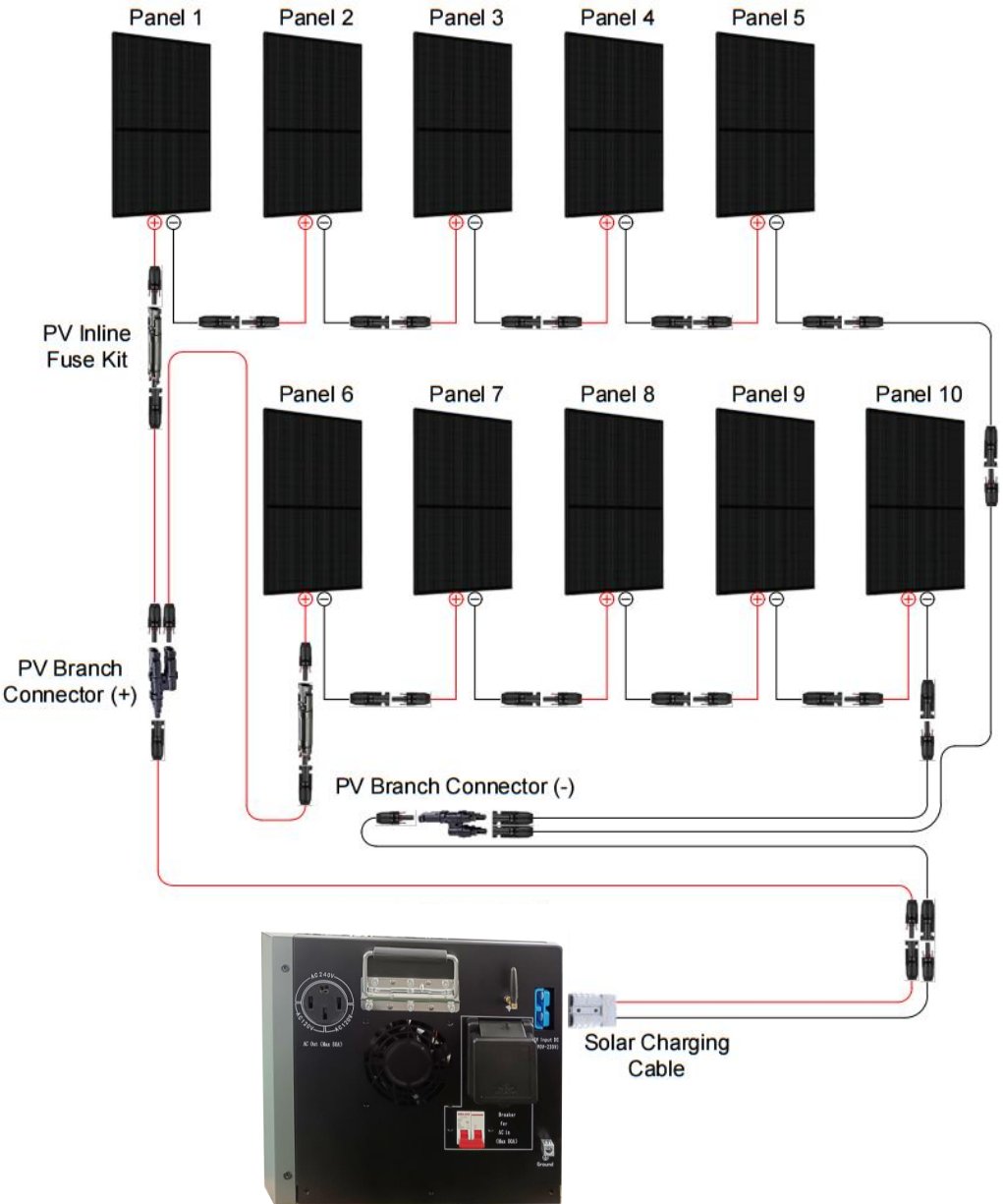

# 4 Connection Overview

## 4.2 Schematic Diagram

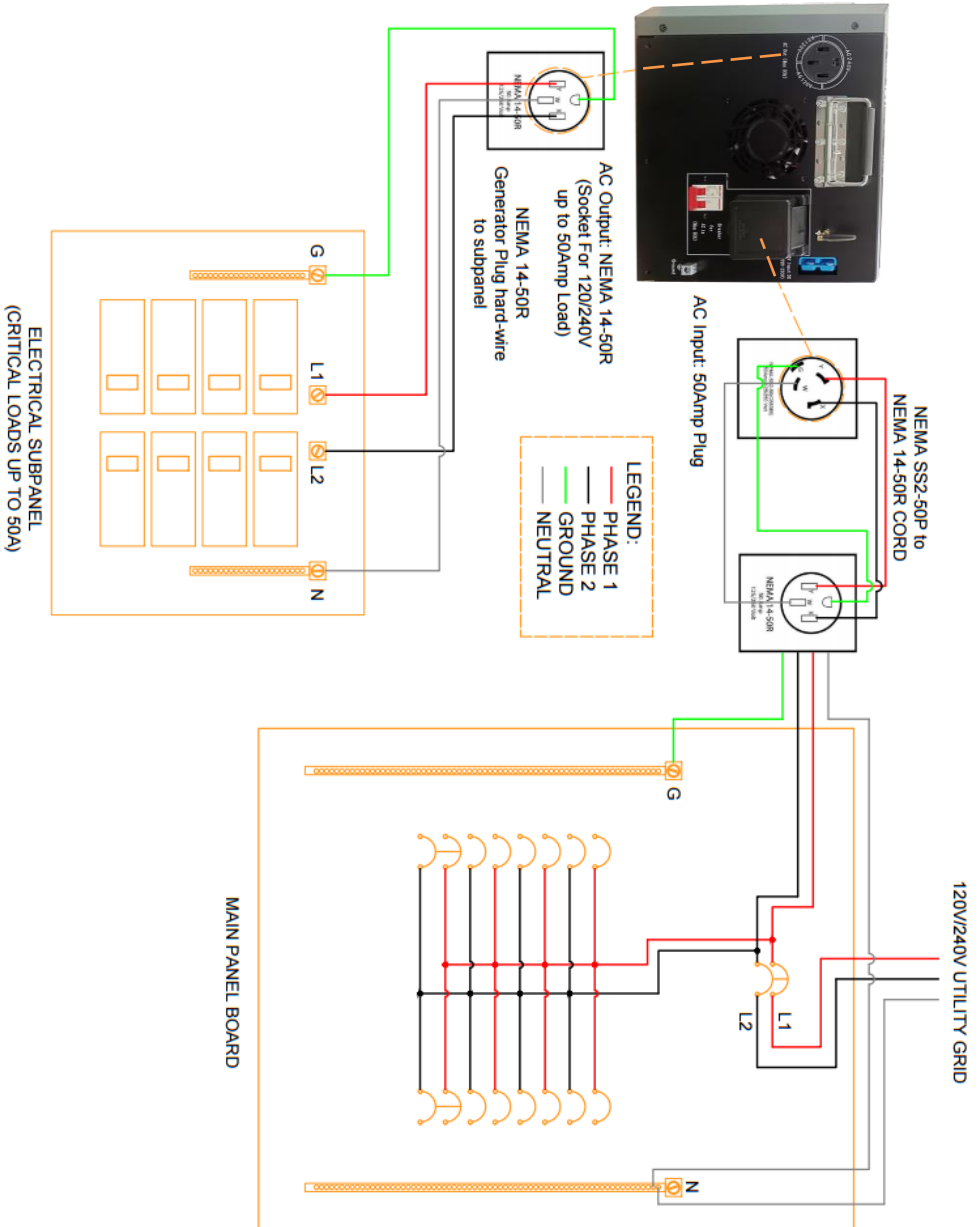

# 4 Connection Overview

## 4.2 Schematic Diagram

### 4.2.1 Phase 1B (Line 1, Line 2, Ground) NEMA 14-50P

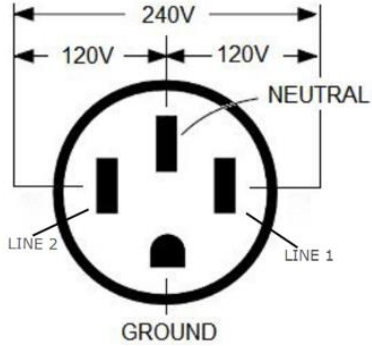

### NEMA 14-30P SCHEMATIC:

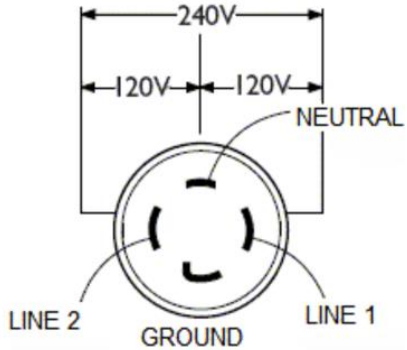

### SS2-50P SCHEMATIC:

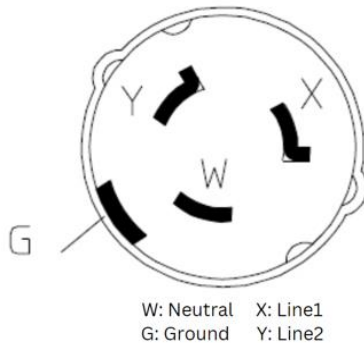
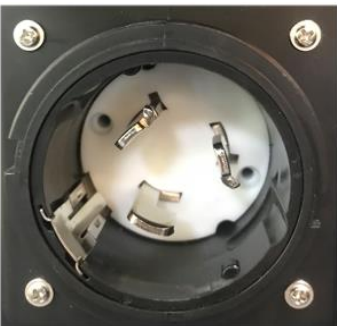

## 5 Installation

### 5.1 Transportation

FORCE 15K's gross weight is 169kg (372.6 lbs). Special equipment is required to load/unload to and from the truck (e.g. forklift)

### 5.2 Choosing a Location

When installing the Force 15K, consider cooling as a top priority for efficient and safe operation. Place it in an area with good air circulation to dissipate heat effectively. The device has two fans: one on the left side (without a connection port) for air intake, and another on the right side (with a connection port) for air outlet. Adequate airflow prevents overheating and extends device lifespan. Avoid narrow or enclosed spaces which hinder airflow. Regularly check and maintain clear air circulation paths around the device to ensure optimal cooling efficiency and prevent obstructions.



## 5 Installation

### 5.2 Choosing a Location

The Force 15K should always be in upright position.

Please maintain the minimum clearances 7.8in (20cm) for adequate heat dissipation.

Never position the unit in direct sunlight. Choose a well-shaded site or a shed to protect the inverter from direct sunlight. PROTECT the LCD screen from excessive UV exposure.

Secure the unit by engaging the breaks of the wheel properly.

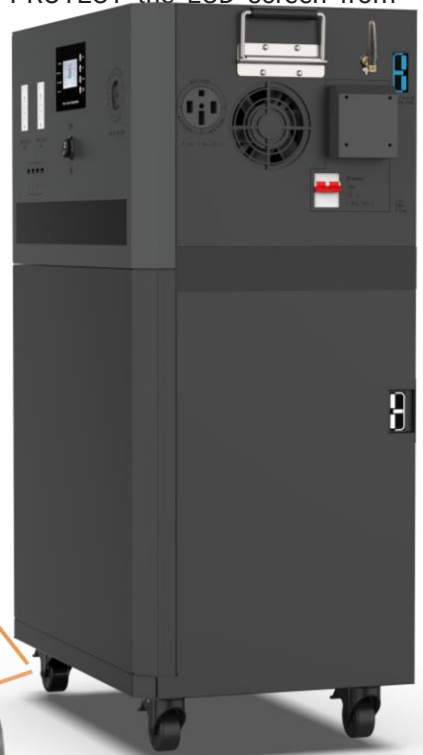

DOWN, Brakes  
ON







UP, Brakes OFF



## 5 Installation

### 5.3 Accessories

| Name  | Description  | Status   | Image   |
|---|--|----------|---|
| PV to BE 175 Cable                              | This cable is used for connections from the PV connector to the blue BE connector.   | In box   |  A blue plastic PV connector with two wires (red and black) extending from it, connected to a black BE connector.                               |
| 48V Battery Charger                             | A 72V battery charger can charge the battery via a DC input. Charging Voltage is 58.4V.  | Optional |  A yellow rectangular battery charger with a DC input cable and a standard AC power cord. A small icon of a 110V AC outlet is shown next to it. |
| Twist Lock Socket (SS2-50P)                     | 120 Volt / 240 Volt Power Cord Twist Lock Socket, which can be installed on the power grid to serve as a connection point for the battery to supply power to the grid. | Optional |  A black twist lock socket with a protective cover that is currently open.   |
| Embedded Ground Blade power Socket (NEMA14-50R) | This socket can be installed on the power grid to serve as a connection point for providing power to the battery from the grid.  | Optional |  A silver metal NEMA 14-50R power socket with a black faceplate.  |
| 50 Amp 10 Ft RV Extension Cable                 | This cable is suitable for connecting the battery output to the power grid.  | Optional |  A black 10-foot RV extension cable with green connectors on both ends.  |

## 5 Installation

### 5.4 Screen Menu

The Force 15K has an interaction area, which includes an LCD, signal indicator lights, and interactive buttons. Users can configure various working parameters on this screen, such as charging power and operational mode, for the Force 15K. Additionally, it provides real-time information on the unit's operational status, including inverter's output power and load percentage, parameters, and working status of each feature.

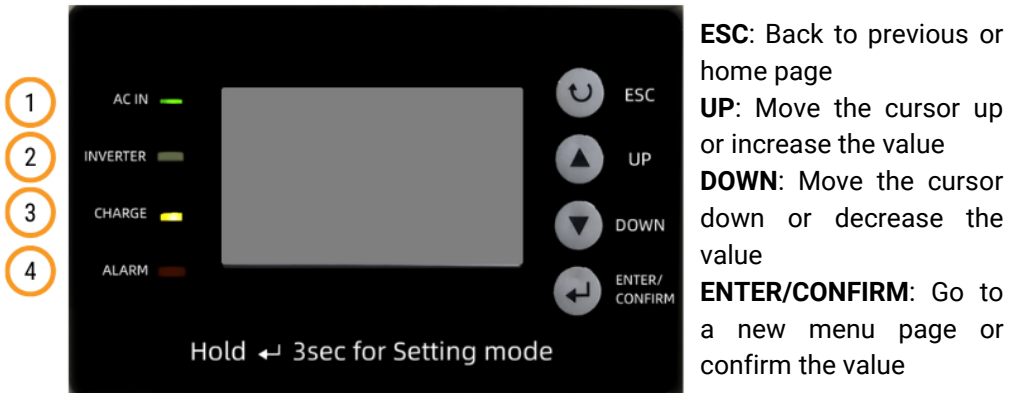

① The green light is the signal of the AC input (grid) connection. The light stays on when the grid is connected to Walrus; the light turns off when disconnected.

② The green light indicates the status of the inverter. When the system relies on battery power, the inverter becomes active, and the light will stay on.

③ The yellow light indicates the status of the charging mode. The light flashes when the battery is charging; when the battery is charged fully, the light stays on until the charging mode is turned off.

④ When the voltage is lower than 48V, the red light flashes with an alarm ring.

**Note:** When the total power of the connected appliances exceeds 8KW, a red light will flash, and an alarm will sound for 30 seconds, after which the system will shut down. Upon hearing the alarm, it is recommended that the total power of the appliances need to be reduced. The system will automatically restart within 3-5 seconds. If the total power of the appliances continuously exceeds 8KW three times, the inverter will shut down completely to protect the system.

## 5 Installation

### 5.5 LCD Screen

#### 5.5.1 Screen Display and Labels

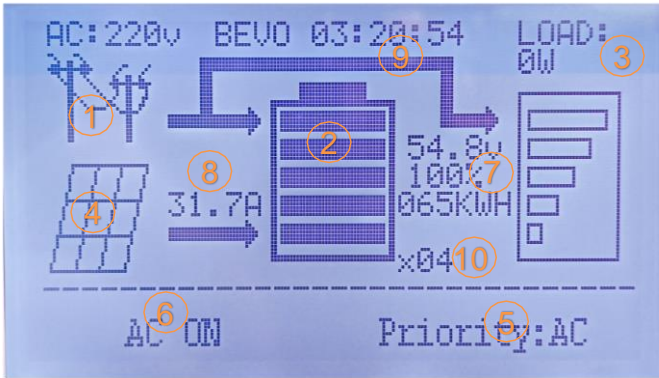

1. Grid Connection Status & Voltage
2. Battery
3. Total Loads (W)
4. PV Connection Status
5. Priority Status
6. Enabling mode
7. Battery Voltage & Capacity Percentage
8. Solar Charging Current
9. Local Time
10. Battery Packs Connected

#### 5.5.2 Password

Press and hold the Enter/Confirm Button for at least 3 seconds to enter screen where password is required, Input **0101**

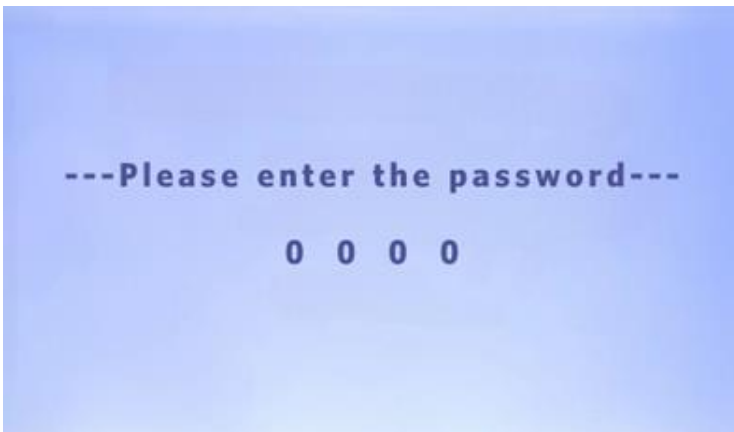



## **5 Installation**

### **5.6 System Configuration**

#### **5.6.1 System Parameters**

Users can only enter this screen after successfully inputting the password from the previous screen. Move the cursor and press the Enter ↵ button to access the selected setting page.



#### **5.6.2 Output Voltage**

Output Option - Output voltage of the standard GFCI class A outlets. NOTE: the output voltage of the Twist Lock Outlet (NEMA L14-30) will be two times the selected voltage. (AC Output = 2 x Voltage).

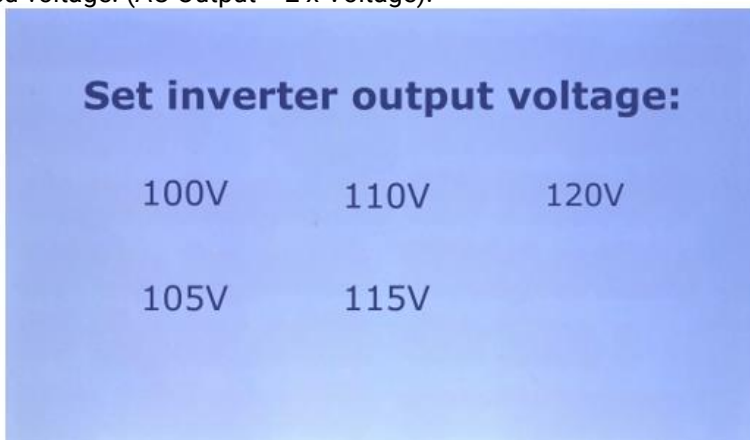

## 5 Installation

### 5.6 System Configuration

#### 5.6.3 Output Frequency

Output Freq. Option - Output Frequency Selection. 60Hz (Default) for North American system.

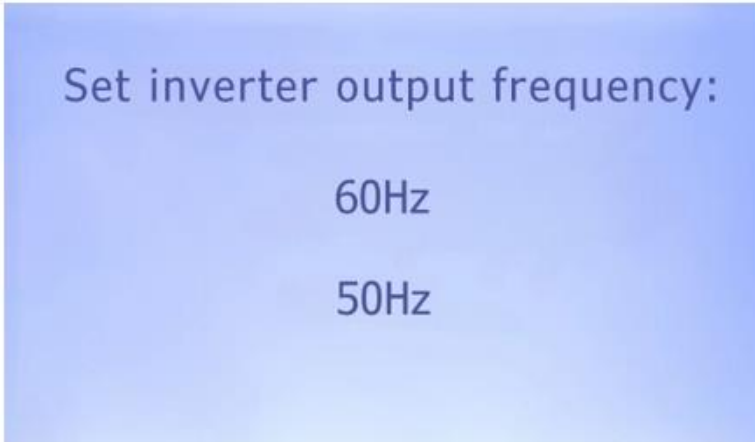

#### 5.6.4 Solar Charging Current

PV Chg Amps Option - Select the Solar Charging Current from the following options:

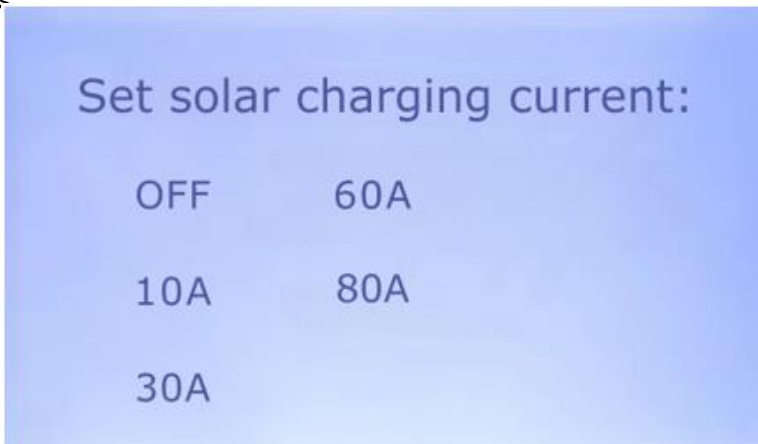

## 5 Installation

### 5.6 System Configuration

#### 5.6.5 AC Input Range

Chg AC Range Option - The AC input voltage range fluctuates depending on the selected power mode: UPS or INV.

Set the AC input range:

UPS: 160V-260V

INV: 130V-280V

Description of the two options:

#### Uninterruptible Power Supply Mode (UPS)

In UPS mode, the device operates using external AC as its primary power source, seamlessly transitioning to battery power in the event of an AC failure, thus ensuring uninterrupted power supply.

#### Inverter Mode (INV)

inverter mode primarily relies on the battery, converting DC to AC power. It can sustain powering loads even in the absence of external AC, provided that the battery maintains a sufficient charge level.

## 5 Installation

### 5.6 System Configuration

#### 5.6.7 Priority

Priority Option - Users can select options from the provided charging modes namely Solar, AC and ATC (AC Time Control)

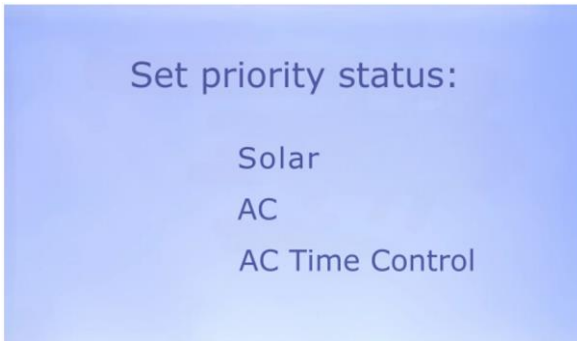

Solar Charging Mode:

- Prioritizes charging from solar power.
- Disables AC charging to utilize solar energy.

AC Charging Mode:

- Allows charging from an external AC power source.
- Permits simultaneous charging from both solar and AC power sources.

AC Time Control (ATC):

- Requires input of local time information.
- Enables scheduling or time-based control of AC charging.
- Ensures efficient utilization of charging resources based on specified time intervals.

## 5 Installation

### 5.6 System Configuration

#### 5.6.7 Priority - AC Time Control



Charge - refers to Force 15K being charged within a specified time frame, where only the bypass power supply mode is active when connected to the grid, allowing the inverter power to concentrate on charging the battery.

Discharge - Unit won't charge at this time, instead, it will operate in an inverter-priority power supply status.

In the provided example from above, Force 15K will be in charging mode from 10 PM to 7 AM the following day. During this time, the battery will select the charging mode based on priorities, and the electricity provided will come from the grid. Conversely, from 4 PM to 9:59 PM, Walrus will be discharging, meaning it won't charge the battery anymore. Instead, it will release stored electrical energy or bypass grid energy to the loads.

NOTE: Please ensure there is no overlap in the time settings for charging and discharging. If there is an overlap, Force 15K will only operate in charging mode during this period until the set charging time ends.

---

## **5** Installation

### **5.6** System Configuration

#### 5.6.8 Battery Parameters

Set Battery Option - Users can adjust the battery parameters on this option:

CC-V: Constant Current/Constant Voltage. The value represents the battery charging voltage;

FLA-V: Float Voltage. It is the voltage at which a battery is maintained after being fully charged to maintain that capacity by compensating for battery self-discharge;

DC-RECR: DC Recover. The voltage of the unit's battery must exceed this value in order for the inverter to restore;

LV-OFF: Low Voltage Cut-OFF. When the battery voltage falls below this set value, the power supply from the battery will be cut off;

LV-ALM: Low Voltage Alarm. Over-low Voltage Warning value, the battery will alarm when the voltage of the unit becomes lower than this parameter;

AC-KCIN: Grid Kick in. When the battery voltage is lower than this, the grid will prioritize charging the battery only when the grid is connected. Once the voltage reaches the set value, DC charging will become available. This may occur when setting the priority to solar, and the solar charging is no longer available.

## 5 Installation

### 5.7 General

#### 5.7.1 Time



Set Time Option - to adjust the unit's local time

#### 5.7.2 LCD Backlight

Choose the LCD backlight mode: selecting 'ON' will keep the LCD screen's backlight constantly illuminated; opting for 'Normal (1Min)' mode will maintain the backlight for one minute during each operation in Full Screen mode.

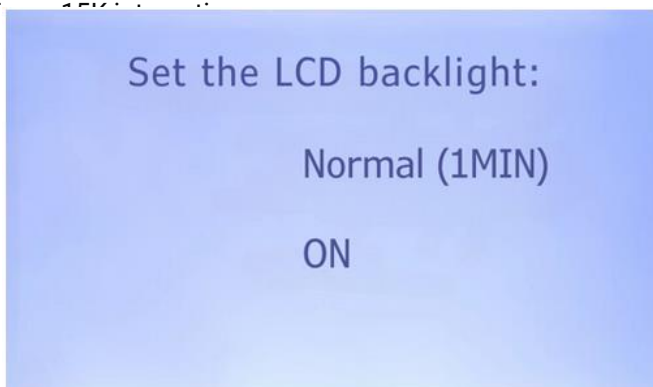

## 5 Installation

### 5.7 General

#### 5.7.3 AC System Status

To view the AC system status, click the Up/Down buttons towards “System Status” Option.

| System Status 1/4 |                |               |           |
|-------------------|----------------|---------------|-----------|
| Input             | AC:231V        | O/P.Freq:50Hz |           |
| HOT               | Output AC:231V | 0W            |           |
| HOT1              | Output AC:115V | Load1:0%      |           |
| HOT2              | Output AC:116V | Load2:0%      |           |
| Batt. Volt:       | 81.0V          | 100%          | Temp:86°F |

AC charging voltage(V), frequency(Hz)

240V AC output socket info

120V AC output socket1 info

120V AC output socket2 info

Battery voltage(V), capacity(%), temperatures(F°)

#### 5.7.4 PV System Status

To view the PV system status, click the Up/Down buttons towards “PV Status” Option.

| MPPT Status 2/4 |           |
|-----------------|-----------|
| PV.Volt :       | 148.4V    |
| Out.Curr:       | 000.0A    |
| PV.Power:       | 0000.0W   |
| PV.Total :      | 0000.7kwh |
| Out.Volt :      | 054.2V    |

Solar charging voltage

Solar charging current

Solar providing power

Solar providing energy

Solar charging voltage



## 5 Installation

### 5.7 General

#### 5.7.5 Charging Status

To view the Charging status of the system, click the Up/Down buttons towards “System Setting Status” Option.

|                       |                                  |
|-----------------------|----------------------------------|
| Set System Status 3/4 | AC charging set current          |
| Set AC Cha:25A        | Solar charging set current       |
| Set PV Cha:30A        | Display backlight setting        |
| BackLight :Normal     | Force 15K priority charging mode |
| Priority :AC          | Force 15K saving mode status     |
| SAVER :OFF            |                                  |

#### 5.7.6 Battery Status

To view the Battery status, click the Up/Down buttons towards “Battery Status” Option.

|                                 |   |
|---------------------------------|---|
| Li-Battery info 4/4             | Battery Charging Voltage Upper Limit            |
| Charge Voltage Limit :00.00V    | Battery Discharge Voltage Lower Limit           |
| Discharge Voltage Limit :00.00V | Battery total charge(+) or discharge(-) current |
| Total System Current :000.0A    | Battery state of charge percentage              |
| Battery SOC :000%               | Battery BMS communication status                |
| BMS Communicate :Abnormal       |   |

## 6 Mobile Application Guide

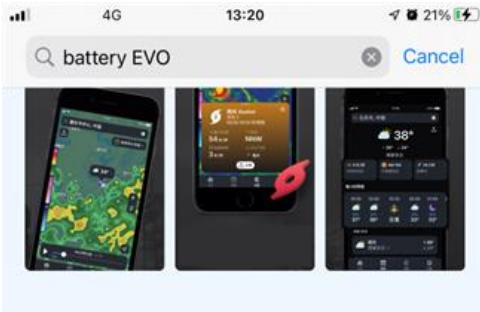

BatteryEvo  
Utilities

OPEN



Today



Games



Apps



Search

### Downloading the App

- Android Users: Open the Google Play Store, search for "BatteryEVO," then select the app from the search results and click "Install."
- iOS Users: Open the Apple App Store, search for "BatteryEVO," select the app, and tap "Get" to download and install it.

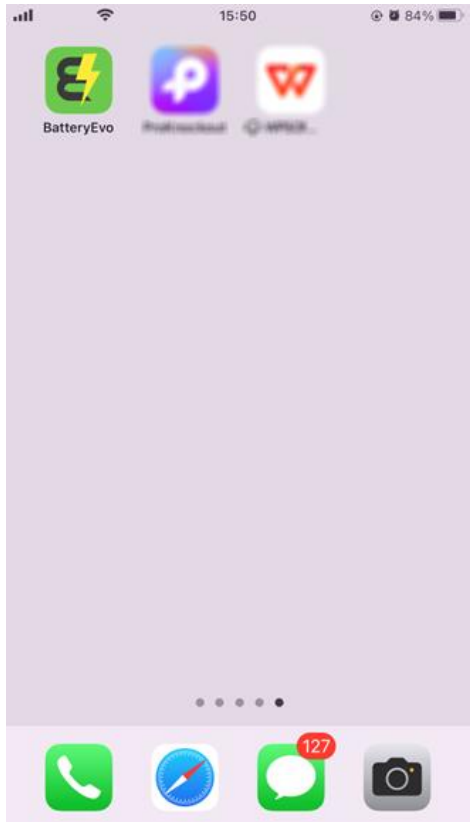

### Installing the App

- Once the download is complete, the app will automatically begin the installation process.
- After installation, you'll find the BatteryEVO app icon on your home screen or app drawer.

## 6 Mobile Application Guide



Username/Phone/Email

Please input password

Remember pwd [Forgot pwd?](#)

I have read and agree [BatteryEvo terms](#)

Sign in

Sign up

Toolbox

Other login way



### Registering an Account

- On the log-in page, select "Sign Up" to register a new Account.
- Fill in the required fields with your details, such as username, email address, and password.
- Read and accept the Terms of Service and Privacy Policy, then submit your registration.
- You may be asked to verify your email address. Check your email inbox for a verification code from BatteryEVO and click on it to confirm your account.

### Logging In to the App

- Open the BatteryEVO app.
- Enter your registered username/email/phone and password, then click the checkbox and tap "Sign in" to access your account.

4G 17:00 20%

Sign up

Sign up for phone [Sign up for e-mail](#)

Username  
Please set username

Mail  
Please fill in your email

Please input the verification code [Obtain](#)

Password  
Please enter password

Confirm password  
Please enter the password again to confirm

I have read and agree [BatteryEvo terms](#)

Sign up now

## 6 Mobile Application Guide

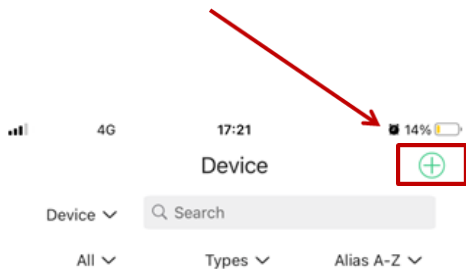

### Add a device (datalogger)

- After logged in, there will be the list of added devices or datalogger.
- To add a new datalogger, you need to click the “+” button.



- Find the PN number and bar code at the top of the Wi-Fi antenna.
- Enter the provided PN number to the input text bar at the bottom, or use the scan option to scan the bar code to get the PN number.
- After the PN number is entered, you can go to the next step.



## 6 Mobile Application Guide

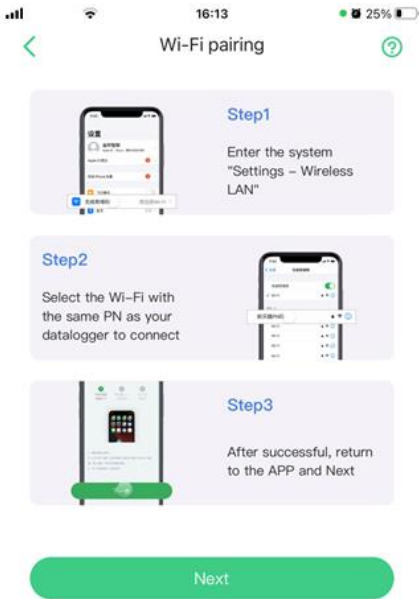

Before the next step, the mobile device should connect to the datalogger as the Wi-Fi connection.

- Select the datalogger network that is the same as the PN number on Walrus.
- The password for the datalogger: 12345678

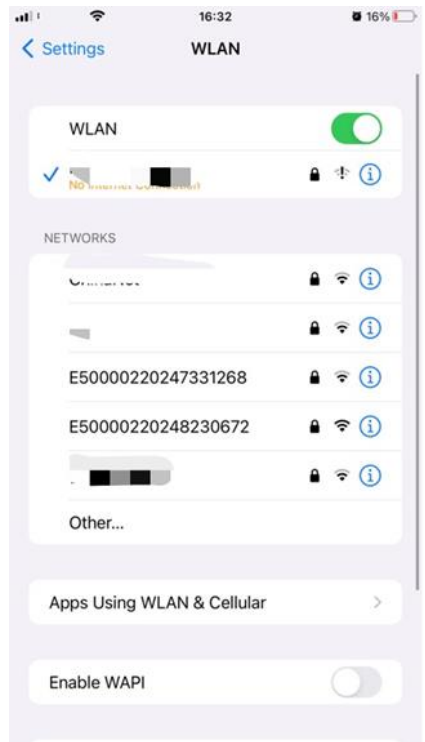

## 6 Mobile Application Guide

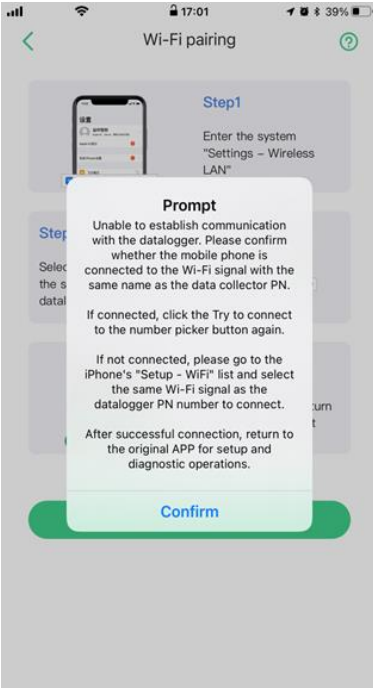

- •Click the “Next” button to access the next page.
- •If a prompt window pops up, the datalogger connection has failed and needs to try again.

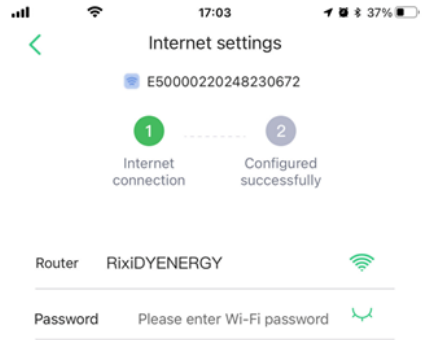

- Enter or select (by clicking the Wi-Fi icon) the local router to which the datalogger should be connected.
- Enter the router's password.

Confirm

### Reminder

1. Please ensure that the signal connecting to the network is good and the network is unblocked.
2. Currently, routers in the 5G band are not supported. Please use routers in the 2.4G band.
3. Ensure that the password of the router is correct.

Setup failed? [Network diagnostics](#)

## 6 Mobile Application Guide



### Bluetooth Pairing

- Click the "Network tools" icon the option box will pop up here.
- Select "BLE network" to go to the Bluetooth pairing setting page.

- Once the network is paired, the mobile device can directly read Walrus's real-time status in the software by connecting to the local network.
- If the system reports an error or the connection fails, then it is recommended that the pair be done again or try another connection solution. Alternatively, contact BatteryEVO technical support team for assistance.

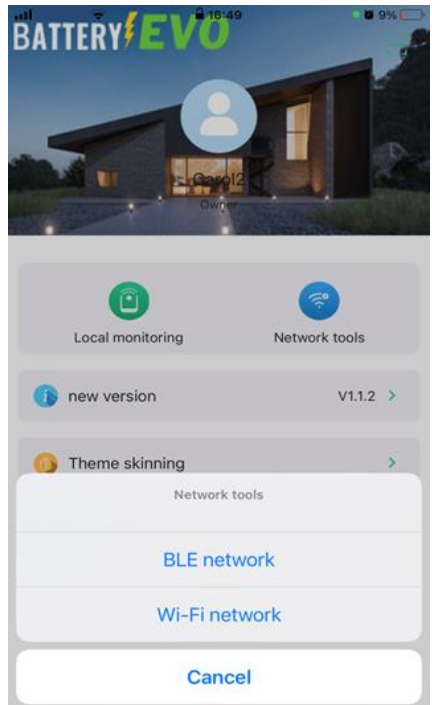

## 6 Mobile Application Guide



Scanning for bluetooth devices...

Make sure the device and phone Bluetooth are turned on and the device is near the phone

- Bluetooth either activates automatically or requires manual enabling.
- The App then initiates a search for nearby devices with Bluetooth capabilities.

- Select the Bluetooth which has same PN number with datalogger from the listed device.

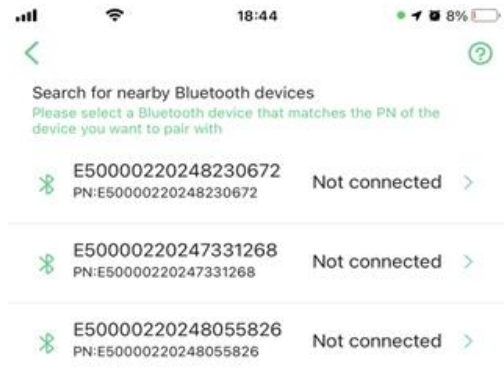



## 6 Mobile Application Guide

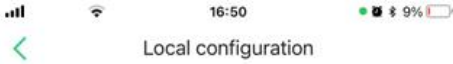

- Bluetooth connected successful to the datalogger.
- Click "Internet Settings" to continue the datalogger pairing to the local router.



You have connected the datalogger:  
E50000220248230672

Internet settings



- Enter or select (by clicking the Wi-Fi icon) the local router to which the datalogger should be connected.
- Enter the router's password.

Set up

Setup failed? [Network diagnostics](#)

## 6 Mobile Application Guide



< Network configuration is successful



Network configuration is successful

Back to the homepage

Network diagnostics

- Once the network is paired, the mobile device can directly read Walrus's real-time status in the software.
- If the system reports an error or the connection fails, then it is recommended that the pair be done again or try another connection solution. Alternatively, contact BatteryEVO technical support team for assistance.

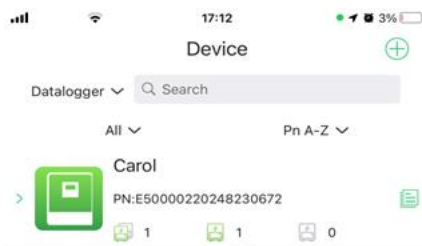

### Viewing Walrus Status

- At the top left of the page, find the drop-down list of presentation types.
- Click on the drop-down list and select "Datalogger". Added dataloggers will be displayed in the list.



## 6 Mobile Application Guide

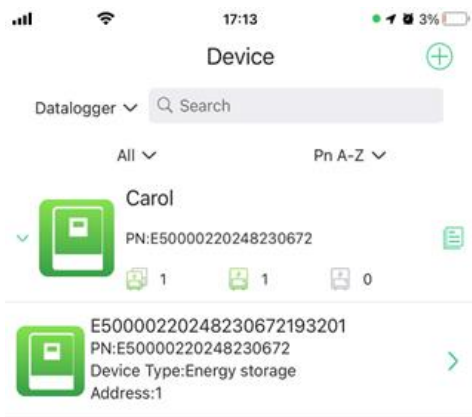

- Click triangle icon on the left of the datalogger. Devices that are already connected to datalogger will be shown below.
- Click the device.



- The system status and data are synchronized in real-time.



---

## 7 Warranty and Returns Information

In the unlikely event you are having an issue with one of our batteries we have developed a straightforward warranty & return policy:

For all returns or warranty claims contact [info@shopsolarkits.com](mailto:info@shopsolarkits.com).

- 30-day money back guarantee. Returns of undamaged batteries unrelated to warranty claims may be issued full refunds less a 20% restocking fee.
- We have a comprehensive 10-year warranty on all new batteries, all cells, accessories & complimentary products (Anderson connectors, wiring, etc.)
- Our batteries are built to last. We stand by our engineering and our quality. If we made a mistake or there is a defect in the build of your battery, we will fix it or fully replace it.
- Mammoth RE offers a 10-year manufacturer's defect warranty from the date of purchase. The average lifespan of a Force 15K battery at 100% Depth of Discharge is between 1,000 – 3,000 recharge cycles depending on chemistry, or roughly 5 to 10 years with standard use (see the specifications of the battery for more information on what standard use would be). This warranty does not cover negligence or misuse of the battery or the normal wear and tear. If it is deemed that the battery was used improperly, you will be subject to a \$150 an hour repair charge plus parts and shipping.
- To submit a warranty claim, please contact us directly at [info@shopsolarkits.com](mailto:info@shopsolarkits.com). The battery may be required to be shipped back to our Mammoth RE warehouse in Chatsworth, California for further inspection.
- Free lifetime technical support & troubleshooting.
- Warranty only applies to original owner (non-transferable).
- Warranties can be used for an exchange of a component only once per component.
- Customer pays return shipping on returns or warranted component inspections initiated after the first 30 days of ownership. Please note some battery returns may require special documentation and packaging, and these instances will encounter extra fees. This is to correctly comply with lithium battery shipping regulations.

---

## 7 Warranty and Returns Information

- If you have a quality issue with a product, please contact our support team to help properly diagnose the problem. If the product you receive does not meet our rigorous quality standards, then we will issue you a replacement component or fix the original at no additional cost. Replacement batteries or components will only be sent after we have received your returned battery or component and finished an inspection to determine the cause of any problems. Mammoth RE is not responsible for return shipping.
- DIY modifications or damage due to gross negligence or abuse are not covered by the warranty.

For all returns, please mail your package in a traceable method to the address below. Include a note with your name, your order number and describing your situation and/or request:

### **ShopSolar.com**

Technical Support Team  
9667 Owensmouth Ave.  
Chatsworth, California  
91311

---

## 8 Warnings and Precautions

Lithium Iron Phosphate (LiFePO<sub>4</sub>) batteries are an inherently safe chemistry. However, as with any electronics, safety measures should always be taken. Please adhere to the instructions within this manual for safe handling and operation.

- Always wear protective gear when handling batteries
- Use a wrench with a rubber coated handle
- Do not place any objects on top of batteries
- Do not place batteries on a metallic surface
- Check that all cables are in good condition
- Make sure all cable connections are properly tightened
- Install and remove batteries using the handles provided
- Do not smoke near batteries
- Do not install batteries in a zero-clearance compartment, overheating may result. Always leave at least 4" of space around all sides and top of battery

---

## 8 Warnings and Precautions

- Keep any flammable/combustible material (e.g., paper, cloth, plastic, etc.) that may be ignited by heat, sparks, or flames at a minimum distance of two feet away from the batteries
- Battery compartment and any material within two feet should be noncombustible.
- Keep sparks, flames, and metal objects away from batteries
- Have a Class ABC fire extinguisher on the premises
- Do not disassemble or attempt to repair the solar generator.
- Ensure that operating environment temperature are strictly followed as specified in the user manual. If the temperature is either too high or too low, it may result in a fire or explosion; performance will be reduced; or the product itself may cease to work.
- The maximum voltage, wattage and current should not be exceeded as per specified.
- Verify first the solar panel's specifications and the generator's solar input before trying to add more equipment. Seek a professional when in doubt.
- Make sure the accessories used are for the specific products or brand only. Do not mix and match accessories. If you need to replace any components or accessories, please refer to the user manual or the website to check relevant information.
- Do not expose the unit to direct heat, rain, moisture, snow, or liquids of any type

---

## 9 Storage Information

### Ideal Operating Conditions:

- Store the solar generator in an environment with temperatures ranging between 20°C ~ 30°C (68°F ~ 86°F).
- Keep the generator away from water, intense heat, and sharp objects.
- Avoid storing in places with temperatures exceeding 45°C (113°F) or falling below -10°C (14°F) to ensure an extended product lifespan.

### Long-Term Storage Guidelines:

- For extended periods of storage, discharge the solar generator every three months.
- If the product is not charged or discharged for more than 6 months, it will not be covered by the warranty.

---

## 10 Frequently Asked Questions (FAQ)

### AC Bypass?

Yes. When the power grid is functioning normally, the inverter operates normally and is in bypass mode. It uses the electricity from the grid for power supply and to charge the battery. When the power grid fails, the inverter will automatically switch to battery supply. This process requires no manual intervention.

### How do I know if the product is charging?

The indicator light beside CHARGE should turn on.

### How do I connect the FORCE 15K to my home panel?

A sub-panel is required when connecting to your electrical home panel. Seek a professional when doing hard-wire installation. When choosing essential loads for your sub-panel, make certain that the combined load capacity, when utilized concurrently, remains within the specifications of the solar generator. Consult a professional for proper computation and recommendations.

### Can this back-feed to my grid?

No.

### Is the Force 15k UL Listed?

The Force 15K is not UL Listed as this is not required for off-grid applications, portable power stations and solar generators. You will not be selling excess power back to the grid with a unit like this, you will be securing your energy independence and investing in a clean, quiet, reliable source of power for years to come.

### How many cells does the battery have?

16 cells connected in series with a single cell voltage of 3.2V each for 48V system.

### What is the battery chemistry?

LiFePO<sub>4</sub>

---

## 10 Frequently Asked Questions (FAQ)

### How does the warranty work?

Each unit is backed by a standard 10-year manufacturer warranty from the date of shipment. The average lifespan of a lithium battery at 90% Depth of Discharge is between 3,000 – 6,000 lifecycles or roughly 5 to 10 years of standard daily use (many more years if used only in backup and recreational situations).

This warranty does not cover negligence or misuse of the battery or the normal wear and tear. If it is deemed that the battery was used improperly, you may be subject to a \$150 an hour repair charge plus parts and shipping.

To submit a warranty claim, please contact us directly at [support@shopsolarkits.com](mailto:support@shopsolarkits.com). The battery may be required to be shipped back to one of our US warehouse locations for further inspection.

### How heavy is the unit?

The unit weighs a total of 395 lbs, however to make moving it easier, we have designed a 2-piece system where you can remove the top inverter portion from the bottom battery portion.

The top weighs approximately 165 lbs, the bottom piece weighs 230 lbs and has wheels for easy maneuverability.

### How does the top connect to the bottom?

The top and bottom are held together with screw-on plates on either side of the unit and connect via a standard SB175 cable which you can see in the product images.

### How quickly can it recharge?

You can recharge the unit from 0-100% with up to 4,000W of solar panels in approximately 4 hours. You can also use both 240V and 120V AC power to recharge the unit.

240V power will recharge the unit much faster than the 120V wall charger included with your order, but we highly recommend “slow” charging the unit from AC power whenever possible to preserve the longevity of the battery.

You can recharge the unit from solar and AC power at the same time.



---

## 10 Frequently Asked Questions (FAQ)

### What is the continuous AC output?

The continuous AC output of the unit is 8,000W at either 120V or 240V. Most appliances you will be running are 120V however things like well pumps, dryers, and some larger AC units require 240V output which the Force 15K can easily handle.

### How quiet is the Force 15K?

The FORCE 15K Solar Power Station operates at an impressive 50 decibels during both standard operation and charging, ensuring a remarkably quiet environment. Multiple decibel rating reports reveals that, even at peak output, it maintains a range of 75-85 decibels—very comparable to the quiet performance of many solar generators and power stations on the market today.

### How long is the surge capacity?

16,000W surge will last for upto 5 seconds, typically to accommodate the momentary increase in power required for starting electrical appliances.

### Energy Saving Mode - how does it function?

In energy-saving mode, when there is no load, the inverter will be in standby mode. It will consume only 10% of the power used in normal mode until it detects the connection of an appliance. In normal mode, the inverter will remain active

### Can I select charging priority?

Yes, the you can configure this in “Priority” on the unit menu.

In solar mode, only solar energy will charge the battery, and AC will not charge the battery.

In AC mode, both solar and AC will work together until the battery is 100%.

In ATC mode, you can set the time for AC to charge the battery, and also set times when the grid power does not participate, relying solely on battery power (typically used to avoid peak electricity prices).

# ***F*ORCE 15K**



**Buy Now:**

<https://shopsolarkits.com/products/force-15k>