

User Manual

EP900 ENERGY STORAGE SYSTEM

Please Read This Manual Before Use And Follow Its Guidance.
Keep This Manual For Future Reference.

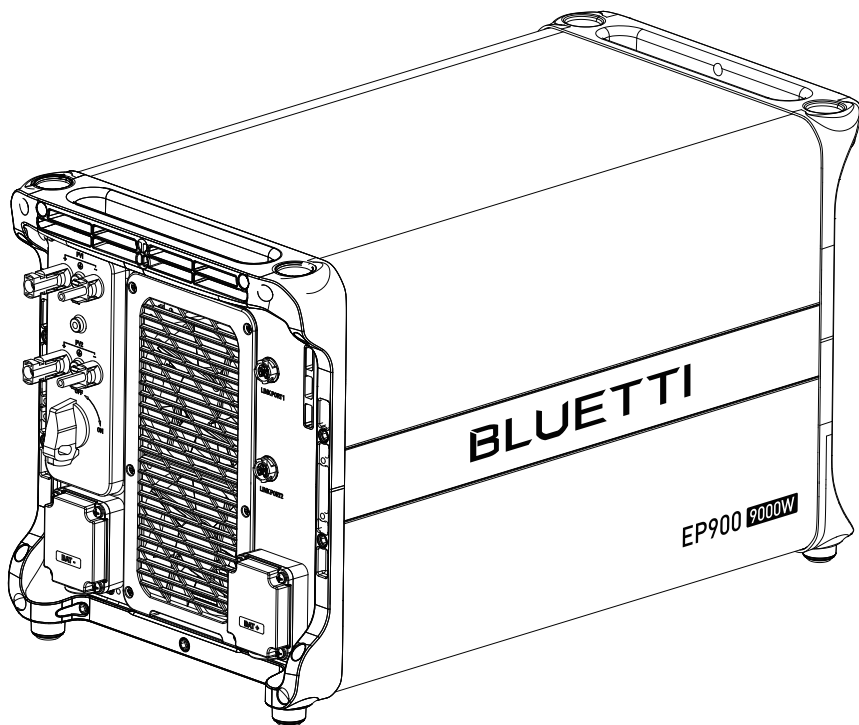



Thank You!

Thank you for making BLUETTI a part of your family.

From the very beginning, BLUETTI has tried to stay true to a sustainable future through green energy storage solutions for both indoor and outdoor use while delivering an exceptional eco-friendly experience for our homes and our world. That's why BLUETTI makes its presence in 70+ countries and is trusted by millions of customers across the globe.

Instruction

Copyright © 2022 Shenzhen PowerOak Newener Co., Ltd. All rights reserved.

No part of this document may be reproduced or transmitted in any form or by any means without the prior written consent of Shenzhen PowerOak Newener Co., Ltd.

Notice

The products, services or features you purchase shall be subject to the commercial contracts and terms of our company. All or part of the products, services and features described in this manual may not be within the scope of your purchase. Unless otherwise agreed in the contract, this manual is only used as a guide, and the company makes no express or implied representations or warranties about the contents of this document. Shenzhen PowerOak Newener Co., Ltd (hereinafter referred to as our company) reserves the right of final interpretation.

The information contained herein is subject to change without notice. For the latest version of this user manual, please visit <http://www.poweroak.net>.

Purpose

This user manual describes the installation, electrical connection, commissioning, maintenance and troubleshooting of EP900 energy storage system, as well as the tutorial of user interface. Please read and understand all instructions in this manual before installing, operating and maintaining the system.

Target Audience

This manual is intended for:

- Installation, operation, and maintenance technicians
- Users who want to learn about BLUETTI app

Symbol Conventions



This manual uses the following symbols to highlight important information:

	Danger
	It indicates a hazardous situation which, if not avoided, will result in death or serious injury.
	Warning
	It indicates a hazardous situation which, if not avoided, could result in death or serious injury.
	Caution
	It indicates a hazardous situation which, if not avoided, could result in minor or moderate injury.
	Attention
	It indicates a potentially hazardous situation which, if not avoided, could cause substantial damage to property and the environment.
	Instruction
	It contains important additional information as well as useful tips for safe, efficient and hassle-free operation of the EP900 energy system.

Contents

1	SAFETY	06
1.1	Safety Instructions	06
1.2	Installation	11
1.3	Electrical connection	13
1.4	Transportation	16
1.5	Packaging Handling	16
1.6	Storage	16
2	EP900 energy storage system	17
2.1	Introduction	17
2.2	Working mode	19
3	EP900 Inverter	21
3.1	Supported Grid Form	21
3.2	Overview	22
3.3	LED Indicator	23
3.4	Buzzer Alarm	24
3.5	Routine maintenance	24
4	B500 Battery	25
4.1	Introduction	25
4.2	Overview	25
4.3	Indicator Description	27
4.4	Maintenance	28
5	System Check	28
5.1	Preliminary Check	28
5.2	Power On	29
5.3	Power OFF	29
6	Dispose of EP900 Energy Storage System	30
6.1	Remove the EP900 Inverter	30
6.2	Recycle the EP900 Inverter and B500 battery pack	30
7	Troubleshooting	31
8	Specifications	35

1. SAFETY

	<p style="text-align: center;">Warning</p> <ul style="list-style-type: none">• DO NOT insert foreign objects into the fans, vents, ports, or other openings.• Keep away from children and pets.• Use genuine accessories from BLUETTI.• Use dry powder fire extinguisher in case of fire.
	<p style="text-align: center;">Instruction</p> <p>This manual does not include all safety instructions to be observed. Please install, operate and maintain the EP900 energy storage system in accordance with electrical safety codes.</p>

1.1 Safety Instructions

1.1.1 General Safety

Please read this manual before operating the equipment.

- The installation, commissioning, and maintenance should only be performed by qualified professionals or trained personnel. Improper or incorrect installation and operation may cause personal injury or property damage.
- Do not keep the equipment near heat sources or in high temperatures.
- Do not store the equipment with flammable liquids, gases, or explosive materials.
- Make sure the place where you are using the equipment is well ventilated and spacious.
- Do not block or cover the openings of the equipment, as this may cause irreversible damage to it.
- Do not stack anything on top of the equipment either in storage or in use.
- Do not move the equipment while it is turned on, as vibration and collision may cause damage to the internal hardware.
- Turn off the equipment IMMEDIATELY in case of malfunction, and contact BLUETTI support team if this manual cannot explain the malfunction adequately to you.
- Do not place the equipment on unstable or inclined surfaces.

1.1.2 Battery Safety

- Use the battery within the temperature range specified in this manual.
- Do not expose the battery to high temperatures or around heat sources, such as sunlight, fire, transformers and heaters. If the battery overheats, it may cause a fire.
- Do not expose the battery to humidity or corrosives, as this may cause the battery to rust, corrode and leak chemicals.
- To avoid leakage, overheating or fire, do not disassemble, modify or damage the battery. For example, do not insert foreign objects into the battery or place the battery in water or other liquids.
- Do not turn the battery upside down or tilt it.
- Do not ignore warning signs on parts or products made by the manufacturer.
- Do not short-circuit the battery terminals. A short circuit can cause a fire.
- Never use damaged batteries or components. Improper use or misuse of damaged batteries or components can damage your device or injure yourself as a result of battery fluid leakage, fire, overheating, or explosion.
- Do not place damaged batteries near flammable materials.
- Do not store damaged batteries near undamaged ones, as damaged batteries may leak flammable liquid or gas. Only qualified professional or trained personnel is allowed to approach damaged batteries.
- Do not perform welding or grinding work around the battery to prevent fire caused by sparks or arcs.
- The fire hazard of lithium-ion battery energy storage system is high. Before handling batteries, consider the following risks:
 - (a) Battery thermal runaway may produce flammable and harmful gases such as CO and HF. Vapors from burning batteries may irritate eyes, skin and throat.
 - (b) The concentration of flammable gases from battery thermal runaway may lead to deflagration and explosion.
 - (c) The battery electrolyte is flammable, toxic and volatile.
- Avoid contact with spilled liquid or gas if the battery leaks chemicals or odors. Do not approach the battery and contact a professional for disposal. Professionals must wear goggles, rubber gloves, gas masks and protective clothing.
- If any part of the battery is immersed in water, do not touch the battery to avoid electric shock.

- Do not use batteries that are soaked in water. In this case, please contact the battery recycling company for handling.
- Electrolyte is corrosive and can cause irritation and chemical burns. If you come into direct contact with battery electrolyte, do the following:
 - (a) Inhalation of Vapors: Evacuate contaminated area, get fresh air immediately, and seek medical attention.
 - (b) Eye Contact: Immediately flush eyes with water for at least 15 minutes, do not rub eyes, and seek medical attention immediately.
 - (c) Skin Contact: Immediately wash the infected area with soap and water and seek medical attention immediately.
 - (d) Ingestion: Seek medical attention immediately.

1.1.3 Personal Safety

- To ensure personal safety and normal use of the equipment, the equipment must be reliably grounded before use.
- Wear personal protective equipment (PPE) during operation. If there is a possibility of personal injury or equipment damage, stop operation immediately, and take appropriate protective measures.
- Use tools correctly to avoid injury or damage to equipment.
- Do not touch energized equipment.
- Do not clean the electrical components inside and outside the cabinet with water.
- Do not stand, lean on or sit on top of the equipment.
- Do not damage the equipment modules.
- When the battery fails, avoid touching the battery and be careful of high temperature.
- Do not disassemble or damage the battery. The released electrolyte is harmful to your skin and eyes. Avoid contact with electrolyte.
- Batteries can cause electric shock and high short-circuit current. When using batteries, please note the following:
 - (a) Remove any metal objects, such as watches and rings, from yourself.
 - (b) Use tools with insulated handles.
 - (c) Wear rubber gloves and boots.
 - (d) Avoid the metal objects to short circuit battery terminals.
 - (e) Do not place tools or metal parts on top of the battery.

(f) Disconnect the charging power source before connecting or disconnecting battery terminals.

1.1.4 Battery Installation Requirements

- Before installing the battery, please check whether the packaging is in good condition. Do not use batteries with damaged packaging, make sure the battery switch is OFF.
- During installation, make sure the screws are properly tightened with a torque wrench and check regularly.
- During installation, make sure that the positive and negative terminals of the battery are not short-circuited. If the battery terminals contact with other metals, it may cause the heat generation or electrolyte leakage.
- After installing the equipment, remove unused packing materials such as foam, carton, plastic and excess cables from the equipment area.

Fire Emergency Measures

	Danger
	<ul style="list-style-type: none">• In case of fire, power off the system if it is safe to do so.• Use carbon dioxide, FM-200 or ABC dry powder fire extinguisher.• Remind firefighters to avoid contact with high-voltage components to prevent the risk of electric shock.• Overheating may cause the battery to deform and leak corrosive electrolyte or toxic gas. Keep away from batteries to avoid skin irritation and chemical burns.

Battery Drop Emergency Measures



Danger

- If the battery pack is dropped, violently impacted or tilted during installation, internal damage may occur. So do not use such battery packs to avoid safety risks such as battery leakage and electric shock.
- If the dropped battery is not obviously deformed or damaged, and there is no abnormal smell, smoke or fire, please contact a professional to transfer the battery to an open and safe place, and contact BLUETTI support.
- If the battery is obviously damaged or there is abnormal smell, smoke or fire, please evacuate immediately, contact a professional or BLUETTI support. Professionals can use fire extinguishing facilities to extinguish the fire under safety protection.

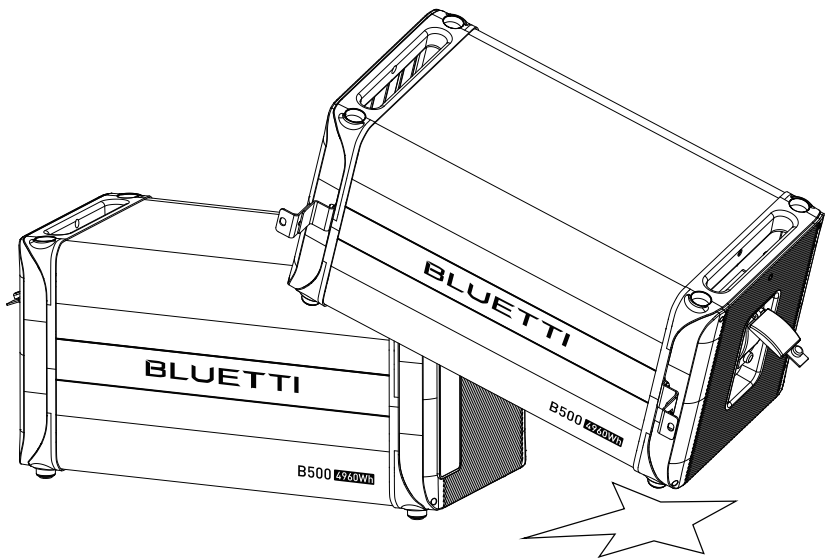

1.1.5 Declaration

BLUETTI shall not be liable for equipment abnormality component damage, personal injury property loss or other damage caused by the following reasons:

- After being installed and connected to the system, the battery is not charged in time, resulting in and gets damaged due to over-discharge.
- Batteries are often over-discharged due to improper maintenance or capacity expansion (eg, mix new and used batteries), or batteries have not been fully charged for a long time.
- Failure to maintain the battery in accordance with the user manual.
- The battery is not charged as required during storage, resulting in the capacity loss or irreparable damage to the battery.
- Batteries are short- circuited, damaged, dropped or leaked due to improper operation or connection errors.
- The battery is used by the customer or a third party beyond the situations specified in the user manual. For example, use with other batteries, including but not limited to other brands of batteries or batteries of different rated capacities.
- The battery is damaged because the working environment does not meet the requirements. The actual operating temperature is too high or too low, or the grid is unstable and power outages occur frequently.

1.2 Installation



Attention

Do not power ON the EP900 energy storage system if it has not been properly installed or commissioned.

- Before starting any work, turn off and isolate all electricity to the property at the main panel.
- Take measures to prevent the electricity from turning back on while working, such as a safety tag and lockout.
- Test the circuit's voltage before proceeding to verify that the course is off.
- After installing the equipment, remove the idle package materials from the site such as cartons, foam, plastic, nylon ties, etc.

- Keep people other than the installation technicians away from the energy storage system.
- When handling equipment and accessories, pack them in their original packaging or other materials to protect them from impact.
- Seal all the wiring ports with fireproof and water-proof materials to prevent possible electric shock or other risks.
- It's prohibited to alter, damage or cover the marking and nameplate of any part of the system.
- Check and make sure all safe guards, including screws and waterproof rings, are in place and properly tightened.
- Keep the system firmly secured to the ground or other solid objects, such as a wall or mounting bracket.
- Use a non-abrasive cloth to clean the equipment and accessories. Do not use water or harsh chemicals.
- Please follow the instructions in the user manual to install the EP900 energy storage system.

1.2.1 Personnel Requirements

The installation, commissioning, and maintenance should only be performed by qualified professionals or trained personnel.

- Personnel who plan to install, commission, or maintain the EP900 energy system should receive rigorous training in all necessary safety precautions and proper operating practices.
- Professional personnel: personnel who has skills and knowledge related to the installation and operation of electrical equipment, and has received safety training to recognize and avoid or minimize the hazards to themselves and other people.

1.2.2 Anti-static Requirements

- Wear or use personal protective equipment (PPE) or clothing that is appropriate for the work; this may include items such as safety glasses or goggles, or a face shield (with safety glasses or goggles), hearing protection, dust mask, gloves, anti-static bracelet, safety boots or shoes, or rubber boots.
- If you use an anti-static bracelet for electrical connections, make sure the bracelet is properly grounded.



1.2.3 Drilling

When drilling holes in the wall or on the ground, the following safety measures should be considered.



- Wear goggles and protective gloves at all times.
- Shield and protect the equipment to prevent debris from falling into it and remove all debris after drilling.
- Drill holes on the unit are forbidden, as this may damage the equipment's electromagnetic shielding performance. The metal shavings may cause short circuits on the circuit board.

1.3 Electrical connection



High voltage generated by the equipment during operation may cause an electric shock, which could result in death, severe injury, or property damage. Please follow the safety instructions in the user manual and relevant electrical safety codes.

	<p style="text-align: center;">Danger</p> <p>Check and make sure the EP900 energy storage system is in good condition. Turn off all switches on the system before connecting to the grid, as it may cause electric shock or other electrical risks.</p>
	<p style="text-align: center;">Warning</p> <p>The specification of cables which used for solar panel must proper, firm connection and good insulation. Incorrect wiring may damage the Energy Storage System , such resulting damage will not within the warranty.</p>
	<p style="text-align: center;">Attention</p> <p>Consult your national or regional electricity authority before connecting an EP900 energy storage system to your home grid.</p>

Operation

	Danger
	<p>Do not touch live parts and cables when EP900 energy storage system is running, as it may result in death or lethal injuries due to electric shock.</p> <p>Do not touch the equipment, as the shell may become hot when it's running.</p>
	Attention
	<p>Handle the equipment and accessories with care during loading, unloading and transportation.</p>

Service and maintenance







	Danger
	<p>High voltage generated by the equipment during operation may cause an electric shock, which could result in death, severe injury, or property damage. Please follow the safety instructions in the user manual and relevant electrical safety codes.</p>
	Danger
	<p>Prior to servicing and maintenance, disconnect the power grid, battery and PV system. Wait at least 5 minutes until the internal equipment is discharged.</p>
	Attention
	<p>Please follow the anti-static requirement to avoid electrical shock and other risks.</p> <p>If any maintenance is required, please contact the local authorized service center.</p> <p>Place temporary warning signs or erect fences to prevent unauthorized access to the maintenance site.</p>

Label Description

Safety labels and warning signs on essential components alert you to potential hazards. Please read and understand these labels before installing your energy storage system.

Attention: Do not alter conceal, falsify, or destroy these labels and signs.

Figure 1-1 Safety label

Label	Name	Description
	Discharge delay	There is still residual voltage after the equipment is powered off. Please wait at least 5 minutes until the equipment is discharged.
	Electrical shock warning	The system generates high voltage during operation. The installation, commissioning, and maintenance should only be performed by qualified professionals or trained personnel.
	Warning	Be careful. Hazards may occur during operation.
	Read instruction	Please read the instruction carefully before operating the energy storage system.
	This side up	It must be transported, handled and stored in the correct orientation. The arrow always faces upwards.
	Weight	The inverter and battery packs are quite heavy and need to be carried by several people.

1.4 Transportation

All components of the EP900 energy storage system leave the factory in optimum electrical and mechanical state. It's necessary to use original or appropriate packaging to ensure the product safety during transportation. When you receive the product, inspect for any kind of damage and note the damage on the delivery receipt. The shipping company will be responsible for any damage or loss of the product during transportation. If necessary, please contact us for further assistance.

1.5 Packaging Handling

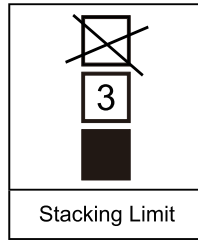
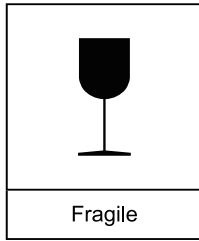
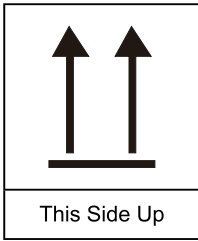

- The symbols on the box contains important information for safe operation.
- The nameplate on the side of the box contains important parameter information related to the product.

1.6 Storage

- When not using the system for extended periods of time, power it off and remove all electrical connections.
- Charge the system to 50%-70% SOC before storage.
- In order to keep the battery healthy, fully charge and discharge the system every six months.
- Make sure the place where to store the system is well ventilated and spacious.
- Do not store the system with flammable liquids, gases, or explosive materials.
- You're strongly recommended to clean the surface frequently with a dry soft cloth.
- Keep away from children and pet.
- Do not stack anything on top of the equipment either in storage or in use.
- Avoid exposing the equipment to rain, humidity or direct sunlight.
- For details of storage temperature, please refer to chapter 8-Specifications.

2. EP900 energy storage system

2.1 Introduction

BLUETTI EP900 is a modular Energy Storage System (ESS) featuring 9000W output, 9000W input and a maximum capacity of 39kWh. With an intelligent Battery Management System (BMS) and reliable Lithium Iron Phosphate(LFP) battery pack, EP900 always gives its optimal performance regardless of the cold or hot weather. Whether you're trying to get rid of high electric bills, are tired of fluctuating power supply that happens now and then, or getting ready for clean energy solutions, the BLUETTI EP900 ESS is right for you.

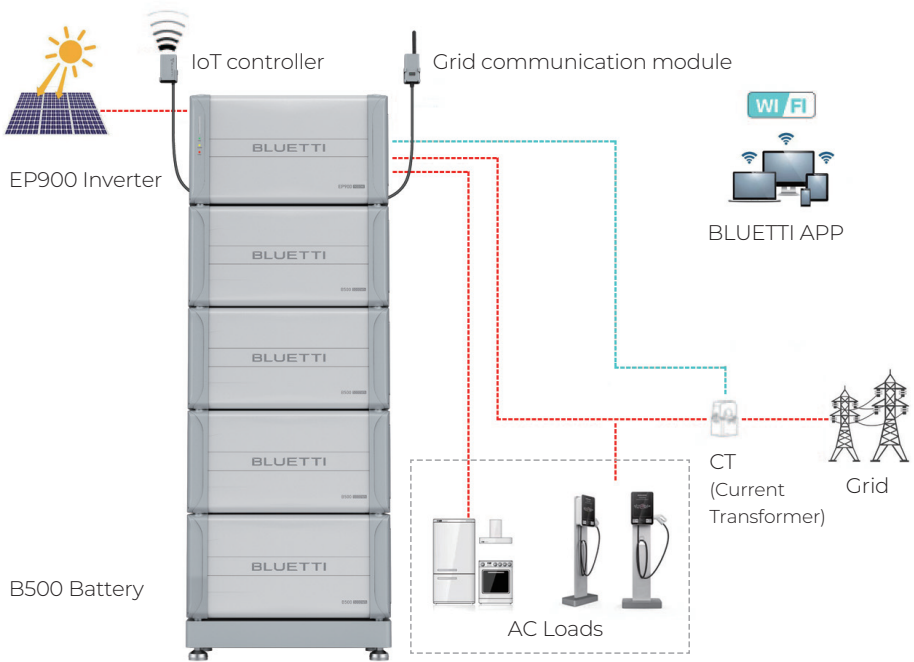

Figure 2-1 EP900 Energy storage system

Item	Description	Note
EP900 Inverter	An energy storage photovoltaic grid-connected inverter to handle photovoltaic input, grid-connected charging, and discharging.	For details, please refer to chapter 3- EP900 Inverter.
B500 Battery	LiFePO4 battery pack to power the EP900 system.	For details, please refer to chapter 4- B500 Battery.
IoT Controller	Monitor and control the EP900 system.	For details, please refer to chapter 5- IoT Controller.
Grid Communication Module	Used for the power interconnection between EP900 ESS and the power grid through WiFi, to optimize the power consumption and enjoy the subsidy policies.	Interconnect with IEEE 2030.5 compliant North American Grid servers for plug-and-play, remote dispatch and data monitoring functionality.
BLUETTI APP	Near-end communication (Bluetooth) or remote communication (WIFI) with EP900 inverter	For details, please refer to BLUETTI APP instructions.
CT (Current Transformers)	Assist in intelligent operation management.	/
Fast breaker	Quickly de-energize a rooftop solar panel system.	/
Safety switch	Used for the security protection of the grid-connected line.	/

2.2 Working mode



Instruction

The introduction describes the general behavior of EP900 energy storage system, and the system operating mode can be adjusted on the APP of this product.

EP900 ESS has four operating modes to cope with different energy plans. Please select the appropriate mode based on your home power supply configuration.

Mode 1

If there is already a grid-connected PV system, combine it with the EP900 ESS by means of AC coupling. The PV power is first used to power the load and then to charge the batteries, and any excess PV power can be fed back to the grid.

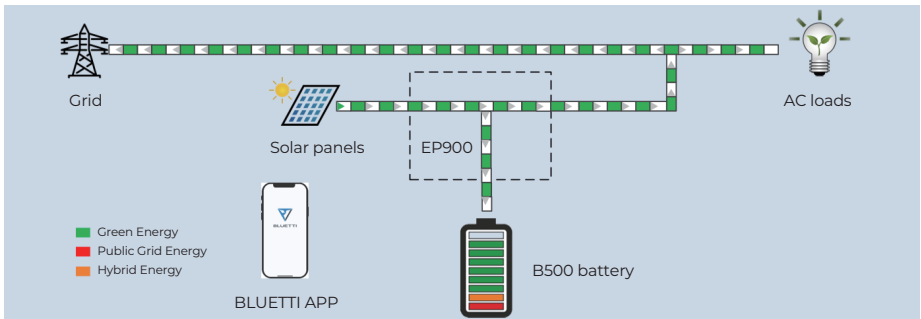

Figure 2-2

Mode 2

When there is no PV system, the load is powered by the backup battery, and then by the grid when the battery is low.

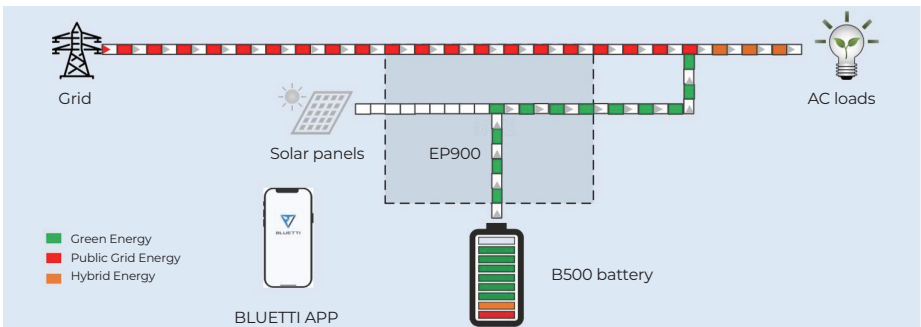

Figure 2-3

Mode 3

If the grid is disconnected, the PV and backup batteries work together to provide power to the load.

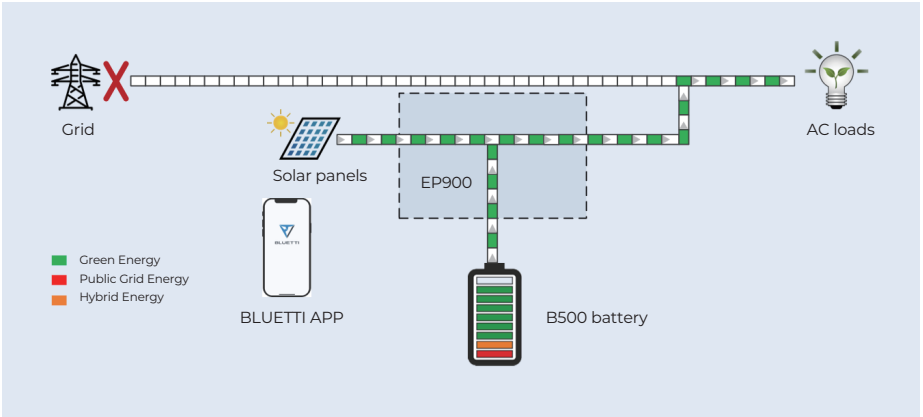

Figure 2-4

Mode 4

Battery can be charged by grid, the charging time and power can be set flexible in APP.

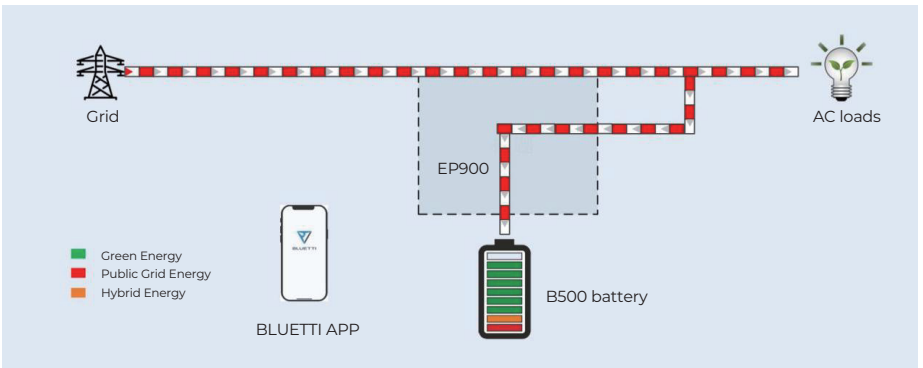

Figure 2-5

3. EP900 Inverter

EP900 inverter is an energy storage photovoltaic grid-connected inverter that can handle photovoltaic input, grid-connected charging, and discharging. It is an important part of the energy storage system.

Features

Take advantage of solar energy: Triple MPPT charge controllers to maximize solar input, while store solar energy in LiFePO₄ batteries. It also works with the grid-connected PV system.

Smart energy storage solution: Intelligent user application mode, which can automatically control the flow of system charging and discharging power or according the user demand to adjust the energy actively.

Uninterruptible power supply (UPS): It takes less than 10ms to switch from off on-grid connection to off grid.

Battery expansion: The ESS supports 2-4 battery packs (B500) to expand the total capacity.

App control & monitor: With WiFi or Bluetooth connection, you can check the system operation anytime and anywhere.

IP65 water-resistant: The ESS is not subject to dust and water splashes from all directions, making it suitable for indoor and outdoor use. If you place the system outside the house, use a cabinet to protect it from direct sunlight.

3.1 Supported Grid Form

The EP900 grid-connected inverter supports low-voltage power grid. The grid form is L1/L2/N, as shown in the following figure.

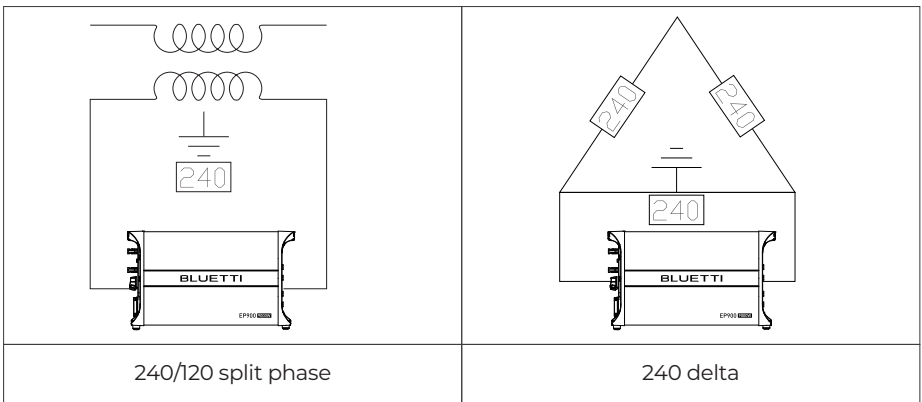
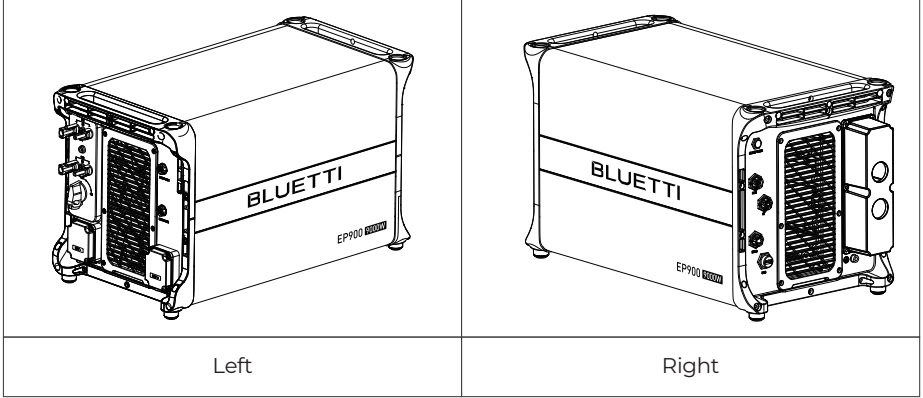

Figure 3-1

3.2 Overview

Appearance

Table 3-1



Dimensions

Table 3-2 (Unit: in/mm)

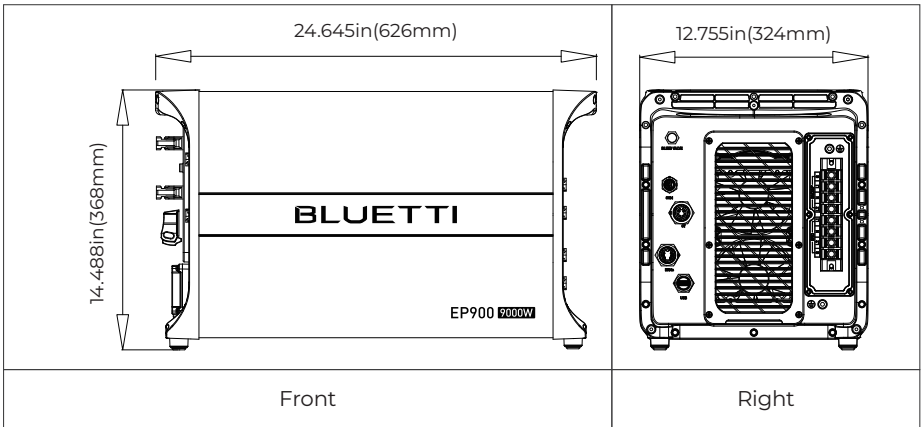

Interface

Table 3-3

Left		Right	
No.	Port name	No.	Port name
1	PV input 1	9	Bleed valve
2	PV input 2	10	COM port
3	DC switch	11	CT port
4	BAT- terminal	12	DRMs port
5	LED indicator	13	USB port
6	IoT signal port (Link Port 1)	14	Load port
7	Battery signal port (Link Port 2)	15	Grid port
8	BAT+ terminal	16	Grounding port

3.3 LED Indicator



Situation	Run	Alarm	Fault
No alarm and fault	ON	/	/
Alarm	ON	ON	/
Fault	/	/	ON
Alarm and fault	/	ON	ON

Figure 3-2

Table 3-4

3.4 Buzzer Alarm

The buzzer beeps 10 times when a fault occurs. Each time lasts for 5 seconds with an interval of 1 second. The buzzer sound can be turned off on your phone.

Table 3-5 Fault Code

Fault Code	Content
5.	BUS overvoltage
6.	BUS2 overvoltage
7.	Battery overvoltage
8.	Inverter overcurrent
9.	Inverter2 overcurrent
10.	LLC1 current overcurrent input
11.	LLC2 current overcurrent input
26.	PV fault
34.	Overcurrent input

3.5 Routine maintenance

To ensure the safe and smooth operation of the EP900 ESS, follow the checklist below for regular routine maintenance.

- Check fans and heat sinks for dust and other debris that may also accumulate on other components within the system, reducing power efficiency and increasing wear and tear.
- Check that fans are running properly, without any noise or other abnormalities.
- Check that all cables are secured. Please use a torque wrench to tighten the AC and DC cable connections annually.

4. B500 Battery

4.1 Introduction

The B500 battery energy storage system is designed for residential and light commercial use. Single B500 battery pack has a capacity of 4.96kWh. BLUETTI EP900 system supports 4 *B500 units for a whopping 19.84kWh, enough to power a house for several days.

The B500 comes with a reliable battery management system (BMS) with a multi-stage architecture that provides real-time detection of the battery pack's voltage, current and temperature, protecting the system from overvoltage, under-voltage, overcurrent, overtemperature and undertemperature. At the same time, the redundancy design provides unprecedented safety and stability for the B500 battery energy storage system.

4.2 Overview

Appearance

Table 4-1

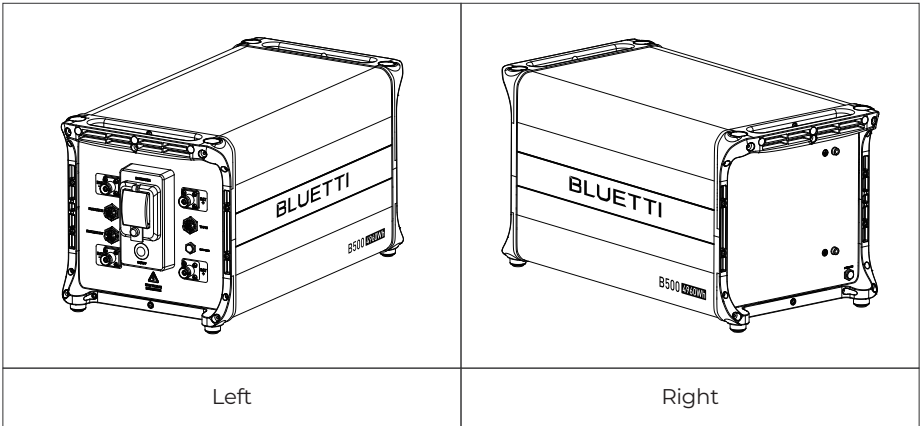

Interface

Table 4-2

Left		Right	
No.	Name	No.	Name
1	BAT- terminal 1	8	Bleed valve 1
2	Pack link-in	9	BAT+ terminal 2
3	Pack link-out	10	Power button
4	BAT- terminal 2	11	Grounding port 1
5	Main switch	12	Grounding port 2
6	BAT+ terminal 1	13	Bleed valve 2
7	Inverter signal port (TO Pcs)		

Dimensions

Table 4-3 (Unit: in/mm)

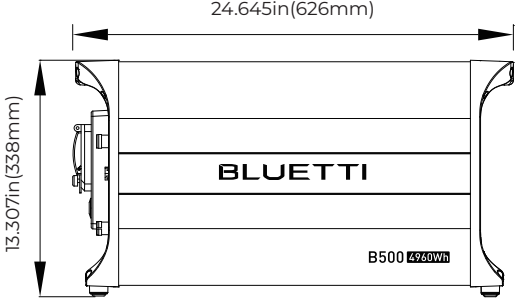
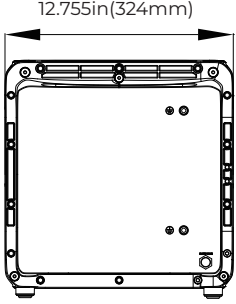
	
Front	Right

4.3 Indicator Description

Light	Meaning	Note
OFF	B500 is not started.	Can operate the circuit breaker.
ON	B500 is running.	Can not operate the circuit breaker.
Flash at 0.5Hz	B500 is shutting down.	Can not operate the circuit breaker.
Flash at 1Hz	B500 is not running.	<p>If all indicators are flashing, the battery module is temporarily unavailable and is restoring, please wait patiently.</p> <p>If it lasts for more than 1 hour, please contact an authorized dealer or our company.</p> <p>If a single indicator flashes, the B500 is in a fault condition. Please contact an authorized dealer or our company.</p>

4.4 Maintenance

- If some of the indicators are off for the battery packs connected in parallel, please contact us or the authorized dealer.
- If you find the B500 battery pack is in a faulty state, please contact us or the authorized dealer.
- If you find the B500 battery pack is temporarily unable to work and is restoring, please wait patiently. If it lasts for more than 1 hour, contact the authorized dealer or our company immediately.
- If the circuit breaker trips, do not operate B500 yourself. Please contact a dealer or our company for further assistance.
- Do not switch off the circuit breaker when B500 battery pack is running, as this may result in abnormal operation of the B500.
- Do not remove the metal shell of B500, as this may cause electric shock and explosion.

5. System Check

5.1 Preliminary Check

Check the followings before first use.

- Confirm that all components of the system are installed according to specific requirements.
- Make sure the PV+/PV- and BAT+ and BAT- cables are connected with correct polarity and proper voltage.
- Switch off all AC and DC circuit breakers.
- Circuit breakers should be selected according to the requirements of this manual and local regulations.
- Make sure grid and load cables are held firmly in place.
- All safety signs and warning labels shall be firmly attached and clearly visible when needed.

5.2 Power On

Step1: Switch on the DC circuit breakers on EP900.

Step2: Switch on the DC circuit breakers on B500 battery packs. Press and hold the power button on any B500 till the indicator on the button light up green.

Step3: Wait for about 40 seconds till the inverter indicator keeps steady green.

Step4: Switch on the AC circuit breakers connected to the EP900 grid port.

Step5: Power on the system via BLUETTI app. For details, please refer to BLUETTI App Instructions.

Step6: Check the output voltage of BACKUP battery.

Step7: Switch on the AC circuit breakers connected to the EP900 load port.

Step8: Check the EP900 system status through the app.

5.3 Power Off

Step1: Turn off the AC power on BLUETTI App.

Step2: Switch off the AC circuit breakers which are connected to EP900 grid ports and load ports.

Step3: Switch off EP900 PV breaker.

Step4: Press the power button on any B500 till the indicator on the button flashes green.

Step5: The indicator continues to flash.

Step6: When the indicator is off, B500 battery packs turn off.

Step7: Switch off main switches for all B500 and the system powers off.



There is still residual voltage after the equipment is powered off, which may cause electric shock or burns. Please wait at least 30 minutes before operating the system.

6. Dispose of EP900 Energy Storage System

6.1 Remove the EP900 Inverter

When the inverter is no longer in use, it must be disposed of properly.

a.Power off the system.

b.Disconnect all electrical connections to the inverter, such as signal cable, DC input cable, power cable, AC input cable, grounding cable, etc.

c.Remove the inverter and related parts.

6.2 Recycle the EP900 Inverter and B500 battery pack

When the inverter or battery pack reaches the end of its lifespan, it must be safely and carefully disposed of by the provisions of local laws and regulations.

Please contact our company for further assistance if the battery pack is

- Leaked or damaged.
- Out of warranty or severely degraded in performance.
- To be replaced or not intended for further use.

7. Troubleshooting

Table 7-1

No.	Error Description	Solution
1.	BUS Overvoltage	Turn off the inverter and wait 30 minutes to restart it. If the symptom persists, please contact the BLUETTI support team.
2.	BUS2 Overvoltage	
3.	BUS Undervoltage	
4.	BUS2 Undervoltage	
5.	Hardware BUS overvoltage	
6.	Hardware BUS2 overvoltage	
7.	Hardware Battery Overvoltage	
8.	Hardware Inverter Overcurrent	
9.	Hardware Inverter2 Overcurrent	
10.	Hardware LLC Input Overcurrent	
11.	Hardware LLC2 Input Overcurrent	
12.		
13.	Auxiliary Power Undervoltage	
14.	DC Component Exception	
15.	Relay Failure	
16.	PV Connection Error	
17.	PV1 Overcurrent	Turn off the inverter and wait 30 minutes to restart it. If the symptom persists, please contact the BLUETTI support team.
18.	PV2 Overcurrent	
19.	Reserved	
20.	PV1 Voltage High	Check if the total voltage of solar panels exceeds the limit. Reduce the number of solar panels, and the inverter resumes operation after calibration.
21.	PV2 Voltage High	
22.	PV3 Voltage High	
23.	PV1 ISO Failure	Check the insulation resistor between solar array and grounding for a short circuit.
24.-26.		

27.	PVI ISO Failure	
28.-30.		
31.	Phase Sequence Error	Check if the grid connection meets installation requirements.
32.	Fan Failure	Check if the inverter fan operates well.
33.	Zero Drift Anomaly	Turn off the inverter and wait 30 minutes to restart it. If the symptom persists, please contact the BLUETTI support team.
34.	Hardware Input Overcurrent	
35.	DC Input Voltage Low	Check if the DC voltage is too low.
36.	DC Input Voltage High	Check if the DC voltage is inconsistent with the battery specifications.
37.-39.		
40.	Inverter Overload	Check if the inverter is overloaded.
41.	L2 Inverter Overload	
42.		
43.	L1 Inverter Output Failure	
44.	L2 Inverter Output Failure	
45.		
46.		
47.	Communication Failure	Turn off the inverter and wait 30 minutes to restart it. If the symptom persists, please contact the BLUETTI support team.
48.		
49.	DSP Communication Interrupted	Turn off the inverter and wait 30 minutes to restart it. If the symptom persists, please contact the BLUETTI support team.
50.	BMS Communication Interrupted	Check that the external communication terminals are connected correctly and restart the device. If the symptom persists, please contact the BLUETTI support team.
51.	IOT Communication Interrupted	
52.	Zero Drift Anomaly-ARM	Turn off the inverter and wait 30 minutes to restart it. If the symptom persists, please contact the BLUETTI support team.
53.	RTC Read and Write Anomaly	

54.	Reserved	
55.	Operating Ambient Temperature Anomaly	Please make sure use the system within specific temperature range. If the symptom persists, please contact the BLUETTI support team.
56.	Temperature 1 Anomaly	
57.	Temperature 2 Anomaly	
58.	Temperature 3 Anomaly	
59.	Temperature 4 Anomaly	
60.	BMS Charge Protection	Check the details on BLUETTI app.
61.	BMS Discharge Protection	
62.	BMS System Failure	
63.-96.	Reserved	
97.	Grid Voltage High	If it occurs occasionally, the grid may go through abnormal working conditions. The inverter recovers after the grid resumes. If it occurs many times, check if the grid voltage and frequency support the inverter input specifications. Check the inverter AC circuit breaker and connections. If the voltage and frequency are beyond the range, please contact the BLUETTI support team.
98.	Grid Voltage Low	
99.	Grid Over Frequency	
100.	Grid Low Frequency	
101.	Reserved	
102.	Grid Loss	
103.	PV1 Voltage Low	Check the PV setup for proper working condition. Solar panels may get a low voltage under improper working conditions.
104.	PV2 Voltage Low	
105.	Reserved	
106.		
107.	DSP_Debug CAN Communication Failure	
108.	DSP_Debug RS485 Communication Failure	
109.-128.	Reserved	
129.	EEPROM Read and Write Anomaly	Please reconfigure the settings on BLUETTI app. If the symptom persists, please contact the BLUETTI support team.
130.-133.	Reserved	

131.	USB Format Error	The USB is formatted as FAT32 with no more than 32G in size. Check if the upgrade files exist or expire. Please download the latest upgrade files.
132.	USB Upgrade Failure	Turn on the inverter again. If the symptom persists, please contact the BLUETTI support team.
133.	Arcing Detection Anomaly	
134.	USB Communication Anomaly	
135.	USB No Upgrade File	
136.	CT Connection Direction Error	Check that the CT connection direction and phase sequence are correct. If the symptom persists, please contact the BLUETTI support team.
140.	Meter communication Failure	Check whether the meter is powered and whether the communication cable between the meter and the EP900 energy storage system is connected normally. If the problem persists, please contact technical support.
141.	Arc pulling module self-test failure	Please restart the machine. If the problem persists, please contact BLUETTI technical support.
142.	Arc pulling module communication failure	Please restart the machine. If the problem persists, please contact BLUETTI technical support.

8.Specifications

Table 8-1 EP900 Inverter

AC (Grid-tied)		
Item	Description	Remarks
Rated Output Power (240V)	9000W	
Wiring mode	L1/L2/N/G	
Rated Voltage	120VAC/240VAC	
Voltage Range	110V~126V/220V~252V	
Rated Output Current	37.5A ×2	
Input Frequency	60Hz	
Frequency Range	55Hz~65Hz	
Maximum Input Apparent Power	13500VA	Bypass + Charge
Maximum Input Current	58A	Bypass + Charge
Power Factor (PF)	1.0	0.9 leading - 0.9 lagging
Current Total Harmonic Distortion (THD)	<3%	
On and Off-Grid Switching Time	<10ms	
Round-trip Efficiency	>85%(AC/AC)	Grid-Battery-AC Load
Protection	Anti-islanding protection Output overcurrent protection Short-circuit protection Over-temperature derating Over-temperature shutdown	PV is on the battery side, with no residual current detection

AC (Off-Grid)		
Item	Description	Remarks
Rated Output Power	9000W	
Output Voltage	120V/240V	
Output Current	37.5A ×2	
Peak Current Ratio	2.4:1	
Output Frequency	60Hz	
Inversion Efficiency	94.4% Max.	
Output Voltage THD	<3%	Purely resistive load
Overload	100%~110%, 10min 110%~150%, 10s >150%, 100ms	
Protection	Output overcurrent protection Output short-circuit protection Over temperature protection	

PV Input		
Item	Description	Remarks
Maximum Input Power	9000W	
MPPT Channel	2	3000W + 6000W
Array In Series	1/2	3000W + 6000W
Maximum Input Voltage	550V	
MPPT Voltage Range/Rated	150V ~ 500V/360V	
Single MPPT Maximum Input Current	12.5A/25A	
Single MPPT Maximum Short-circuit Current	15A/30A	
MPPT Efficiency	99.9%	
PV Inversion Efficiency	97.0% Max.	
Protection	Reverse polarity protection Insulation resistance detection Arcing detection	

General	
Item	Description
Relative Humidity	5%-95%
Static Power	23W
Standby Power	75W
Working Temperature	-4~122°F
Noise	≤50dB (A)
Cooling	Forced air cooling
Protection Grade	IP65
Working Altitude	<2000m
Dimensions (L*W*H)	636mm×324mm×368mm
Net Weight	44kg
Communication	USB/WiFi/Bluetooth
Warranty	10 Years

Compliance	
Item	Description
System	UL9540
Inverter	UL1741, UL1741 SA
Grid Connections	UL1741 SA, SB, IEEE1547, IEEE1547.1, CSA22.2, No.107.1, UL1998, California Rule 21
Emissions	FCC Part 15 Class B
Surge Protection	IEEE C62.41 Class B
Others	NEMA 4X, CEC Efficiency, California Proposition65

Table 8-2 B500

Battery		
Item	Description	Remarks
Battery Type	LiFePO4	Lithium iron phosphate cells
Battery Voltage	99.2V	3.2V×31
Rated Capacity	4960Wh	Charging: 0.5°C/3.6V/0.05°C Discharging: 0.5°C/2.5V (25°C)
Usable Capacity	4464Wh	90% DOD Charging: 0.5°C Discharging: 0.5°C (25°C)
Cell Overvoltage Protection	3.7V	
Cell Undervoltage Protection	2.5V	
Maximum Input Voltage	108.5V	3.5V×31
Minimum Output Voltage	86.8V	2.8V×31
Maximum Input Current	25A	The continuous input current is affected by temperature and SoC.
Maximum Output Current	50A	The continuous output current is affected by temperature and SoC.
Short-circuit Protection	Yes	
Discharging Over Temperature Protection	141.8°F	
Discharging Over Temperature Recovery	127.4°F	
Discharging Under Temperature Protection	-7.6°F	
Discharging Under Temperature Recovery	-0.4°F	
Charging Over Temperature Protection	132.8°F	
Charging Over Temperature Recovery	116.6°F	

Charging Under Temperature Protection	30.2°F	
Charging Under Temperature Recovery	33.8°F	
Charging Strategy	BMS Orders	CC/CV

General			
Item	Description	Remarks	
Noise	<25dB	No fan	
Number of Battery in Parallel	Up to 4 batteries supported	System capacity will be halved at 2 packs.	
Operating Temperature	Charging	32°F~104°F	
	Charging	-4°F~104°F	Inverter connects to the grid.
	Discharging	-4°F~104°F	
Storage Temperature	-4°F~104°F/At least one charge cycle per month. 32°F~95°F/At least one charge cycle every six months.		
Working Humidity	5%-95%		
Working Altitude	<2000m		
Cooling	Forced air cooling		
Protection Grade	IP65		
Installation	Up to 4 batteries stacked on the ground		
Net Weight	58kg		
Compliance	IEC62619, UL1973, UL9540A, UN38.3, EN/IEC 61000-6-1, EN/IEC 61000-6-3, IEC60529, IEC60730-1, FCC Part 15 Class B		

* Please contact us for more details.

For more information, please visit:

Web: <https://www.bluettipower.com>
Add: 6185 S Valley View Blvd Ste D, Las Vegas, NV 89118.



@ BLUETTI Support
@ BLUETTI Official



@ bluetti_inc



@bluetti.inc



@bluetti_official



service@bluettipower.com



Just Power On