



## Rechargeable Lithium battery Operation and Maintenance manual

Version: V1.2

## Description

---

This manual describes in detail the requirements and procedures for safe installation and operation of RUIXU lithium battery pack. Please read this manual carefully, only qualified persons are allowed to install, operate and maintain the system, otherwise it may cause product damage or personal safety risks.

Any actions against safety operation, or do not follow rules of this manual and limited warranty letter, will void warranty and qualification of this product. Meanwhile, the manufacturer will be not responsible for the product damage, property damage, personal injury or even death.

The information contained in this manual is accurate when it's issued. RUIXU reserve right to change specification (such as optimization, upgrade or other operations) without prior notice, please always view the latest document via QR code on the label.

In addition, please noted that the diagrams/schematics in this document are used to help understand system configuration and installation instructions, which may be different from the actual items at the installation.

# Content

<b>1. Information</b>	2
1.1 Validity	2
1.2 Target Group	2
1.3 Levels of warning messages	2
1.4 Symbol Description	3
1.5 Abbreviation Description	4
<b>2. Safety</b>	5
2.1 Safety precautions	5
2.2 Safety instructions	5
2.2.1 Safety gear	6
2.2.2 Emergency safety measures	6
2.2.3 Other Tips	7
<b>3. Product Overview</b>	8
3.1 Introduction	8
3.2 Features	9
3.3 Specification	10
3.3.1 Dimension	10
3.3.2 Parameters	10
3.3.3 Panel Interface	11
3.4 Protection	14
<b>4 Installation</b>	16
4.1 Preparation	16
4.1.1 Safety Compliance	16
4.1.2 Environment	16
4.1.3 Tools	16
4.2 Inspection	17
4.2.1 Unpack precautions	17
4.2.2 Scope of delivery	17
4.2.3 External cable kits	18
4.3 Start Installation	19
4.3.1 Remainder	19
4.3.2 Procedures	19
<b>5. Cable connection and commissioning</b>	20
5.1 Get battery ready	21
5.2 Grounding cable connection	21
5.3 Communication cable connection	22
5.4 DC power cable connection	23
5.5 Connecting with inverter	23
5.6 Commissioning	25
5.7 Switch off battery	25
<b>6. Transport, Storage</b>	27
<b>7. Disposal of battery</b>	27
<b>Appendix I</b>	28

## 1. Information

### 1.1 Validity

This document is valid for: RX-LFP48100 Battery Pack.

### 1.2 Target Group

This document is intended for qualified persons and operators. Only qualified persons are allowed to perform the activities marked in this document with a warning symbol and the caption "Qualified person".

Qualified persons must have the following skills:

- Knowledge of how lithium iron phosphate batteries work and are operated.
- Knowledge of how an energy storage system (including PV/battery/hybrid inverter, MPPT, Meter, Distribution box etc.) works and is operated.
- Knowledge of local applicable connection requirements, standards, and directives.
- Training in the installation and commissioning of electrical devices, batteries.
- Training in how to deal with the dangers and risks associated with installing, repairing and using electrical devices, batteries.

### 1.3 Levels of warning messages

The following levels of warning messages may occur when handling the product

#### DANGER

Indicates a hazardous situation which, if not avoided, will result in death or serious injury.

#### WARNING

Indicates a hazardous situation which, if not avoided, could result in death or serious injury.

#### CAUTION









Indicates a hazardous situation which, if not avoided, could result in minor or moderate injury or product permanent damage.

## ⚠ NOTICE

Indicates a situation which, if not avoided, can result in property damage or product not work or accelerated product damage



## 1.4 Symbol Description

### 1.4.1 Symbols on products label

Label	Definition
	Beware of electrical shock
	Do not place the battery within children/pet touchable area.
	Do not place the battery near heat source and flammable material
	Do not expose the battery to direct sunlight, rain and snow.
	Do not short circuit the battery
	The certificate label for Safety by TÜV Rheinland
	The UL1973 certificate label for Safety by Intertek
	The certificate label for European EMC directives
	The certificate label for U.K EMC directives

	Recycle label
	WEEE designation

## 1.4.1 Other symbols

Label	Definition
 <b>Qualified person</b>	Indicates activities that can only be performed by qualified persons
	Grounding point

## 1.5 Abbreviation Description

Abbreviation	Definition
Battery/battery pack/battery module	Single RX-LFP48100 rechargeable lithium iron phosphate battery pack including cells, BMS and enclosure etc.
Battery system/cluster	Multiple RX-LFP48100 battery pack connected in parallel with power, communication and grounding cables and installation auxiliaries.
BMS	Battery management system Electronical Unit to ensure lithium cells' safety and display information or control the battery work mode.
SOC	State of charge The battery state of charge refers to the percentage of the remaining capacity and rated capacity of the battery.
SOH	State of health The battery health status refers to the percentage between the full charged capacity and the rated capacity of the battery.
DIP switch	Dual in-line package switch

## 2. Safety

### 2.1 Safety precautions

#### DANGER

##### Explosion risk

- Do not impact the battery with heavy objects.
- Do not squeeze or pierce the battery pack.
- Do not throw the battery pack into the fire.

#### WARNING

##### Fire risk

- Do not expose the battery pack to the condition over 80°C.
- Do not put the battery near a heat source, such as a fireplace.
- Do not expose the battery pack to direct sunlight or raining.

#### CAUTION

##### Electric shock risk

- Do not allow non-qualified person to disassemble the battery pack.
- Do not touch the battery pack with wet hands.
- Do not expose the battery pack to moisture or liquid environment.

#### NOTICE

##### Damage risk

- Do not short-circuit or reverse connect the battery.
- Do not use chargers or charging devices unapproved by the manufacturer to charge the battery.
- Do not mix batteries from different manufacturers or different kinds, types or brands.

### 2.2 Safety instructions

The battery has been designed and tested in accordance with international (such as UL, IEC, UN38.3 etc.) safety requirements. However, Due to various factors during the whole lifetime process, RUIXU cannot

guarantee absolute safety, in order to prevent personal injury and property damage and ensure long-term operation of the battery, please do read and following the below section carefully to operate the battery and handle emergency situations.

## 2.2.1 Safety gear

It is required to wear the following safety gear when installing and handling the battery pack.



Insulated gloves



Safety Glasses



Safety Shoes

## 2.2.2 Emergency safety measures

### Water invasion

Please cut off the AC power supply of the system first and then disconnect all switched under the premise of ensuring safety.

### Electrolyte or gas leakage

If the battery pack leaks electrolyte, avoid contact with the leaking liquid or gas. If one is exposed to the leaked substance, immediately perform the actions described below.

- **Gas Inhalation:** Evacuate the people in the contaminated area and seek medical aid immediately.
- **Eye Contact:** Flush your eye with clean and flowing water for 15 min, and seek medical aid immediately.
- **Skin Contact:** Thoroughly rinse the exposed area with soap and water to be sure no chemical or soap is left on them, and seek medical aid immediately.
- **Ingestion:** Induce vomiting, and seek medical help immediately.

### WARNING

In case of fire situations, please use carbon dioxide fire extinguisher rather than liquid to put out fires.



## 2.2.3 Other Tips

- All the product are strictly inspected before shipment, please contact us for replacement if you notice there's any defectives such as swelling.
- Do not disassemble batteries and components, otherwise the manufacturer will not be responsible for any damage caused by unauthorized disassembly or repair.
- Do enable the battery to be safely grounded before use to make sure the system in safe and normal operation.
- Please ensure that the electric parameters of these devices are compatible mutually before connecting the battery to other devices.
- Please take the environmental factors into careful considerations to ensure that the system can work in a suitable condition as the environment and storage methods have a certain impact on the service life and reliability of this product.

## 3. Product Overview

### 3.1 Introduction

The RX-LFP48100 battery is designed for residential application and works as a storage unit in the photovoltaic system. It is a 48V Li-ion battery storage system, with BMS inside itself. It could be operated in both on-grid, back-up and off-grid modes with compatible inverters. Below is the general schematic of an ac-coupled system.

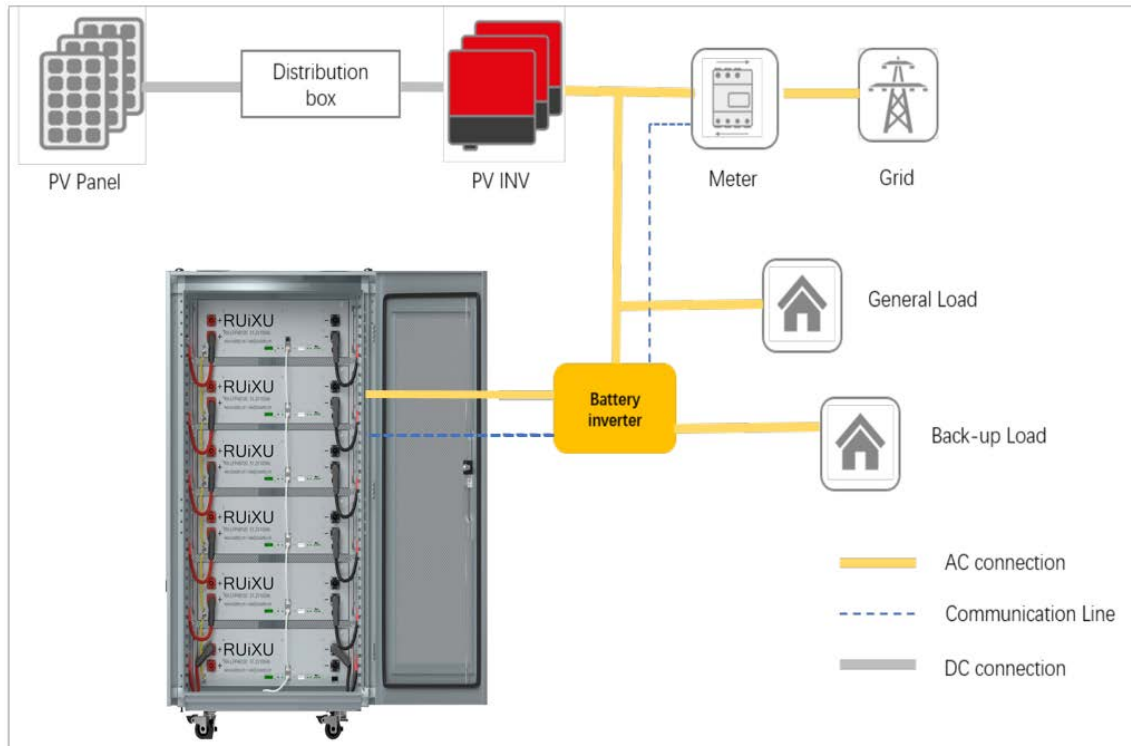

### ⚠ CAUTION

This electrical connection in this diagram is only for illustration, please follow the Manual suggestions of related devices and operate in accordance with locally applicable connection requirements, standards, and directives.

## 3.2 Features

- Highest safety, battery is made from LiFePO<sub>4</sub> chemistry and comply with highest international safety and transport standard.
- Modular and flexible, support up to 32 batteries connect together to expand the system energy.
- Build-in pre-charge circuit to avoid rush current when connecting with different inverter/chargers.
- Automatic dynamic addressing function when connected multiple batteries together.
- Rapid shut down function for North American market.
- Support a maximum of 96% DOD under off-grid and back-up application
- Built in BMS provide warning and protection functions including over-discharged, over-charged, over-current, short-circuit and high/low temperature.
- LiFePO<sub>4</sub> as cathode material and automatic balancing function to meet long cycle life
- Compact size and light weight for easy installation and maintenance.
- Multiple installation bracket to adopt with different customers' requirement.
- CAN/RS485 port for external communication and upgrade the BMS firmware.

## 3.3 Specification

### 3.3.1 Dimension

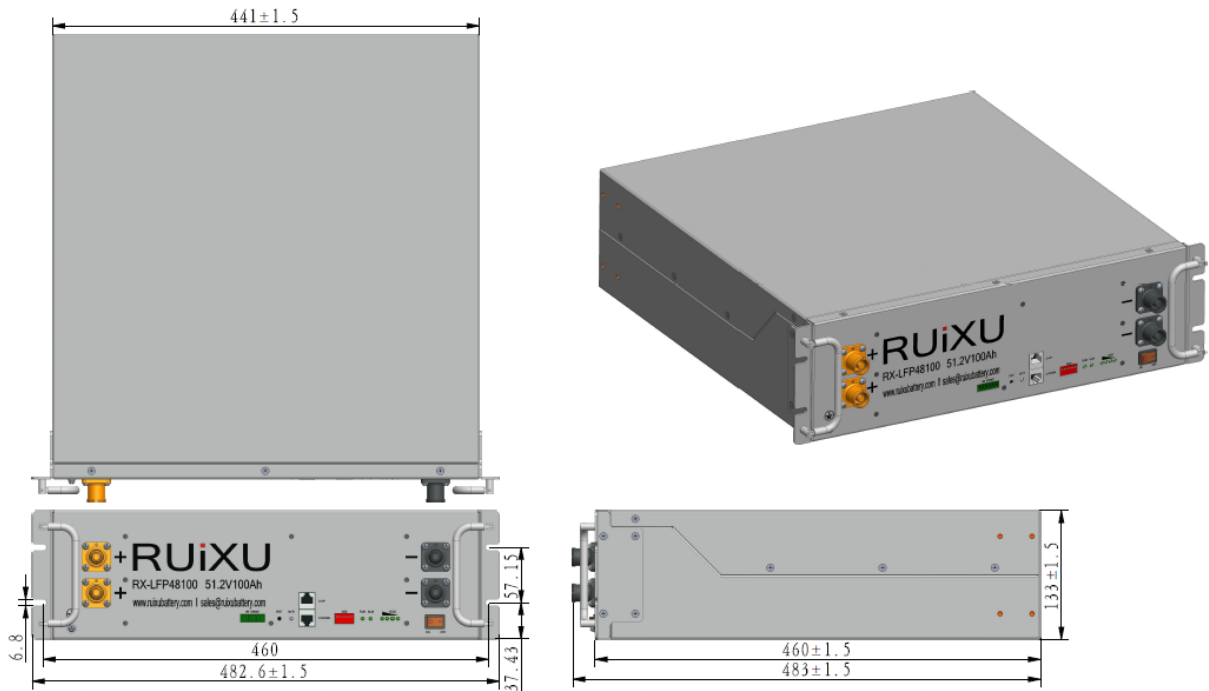

### 3.3.2 Parameters

Items	RX-LFP48100
Rated voltage	51.2V
Max. voltage range	44.8~57.6V, Shipping voltage>51.2V
Charge voltage	56.0V
Float charge voltage	54.6V
Low voltage cut-off	44.8V
Nominal energy	5.12KWh
Usable energy	4.92kWh
Nominal capacity	100Ah
Dimension	482*133.5*460mm (18.9*5.2*18.1 inch)
Weight	~46kg (101lb)
Standard charge current	≤50A
Max. charge current	70A
Standard discharge current	≤50A
Max. discharge current	100A (initial temp. ≤35°C)
Peak discharge current	101~119A@5mins   120~200A@5S
Communication	RS485 /CAN

Max parallel number	32pcs	
Operation temperature <sup>1</sup>	Charge: 0~50°C Discharge:-20~50°C	
Storage temperature	0°C<T<30°C	< 6 months
	-10°C<T<45°C	< 3 months
	Recommended environment	15~35°C, 5~75%RH

## ⚠ NOTICE

The optimum operating temperature range is from 15°C to 30°C, Frequent exposure to the harsh temperatures may worsen the performance of the battery pack and cycle life.

### 3.3.3 Panel Interface

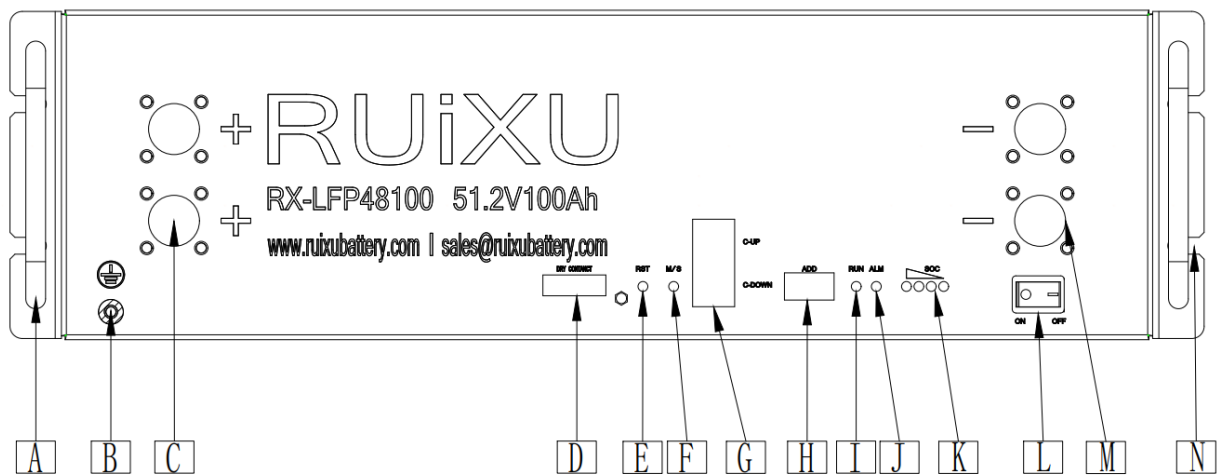

No.	Items	Usage description	Remark
A	Handles	For handling, intallation and disassembly of battery	
B	Grounding	Used to connect battery with ground	
C	Positive terminal	Used to connect the inverter/charger	
D	Dry contact	2 channels output signal 1 channel input signal	Pin1 on the left
E	Reset	Used to reset the BMS	
F	M/S	Used to indicate the module is Master or Slave battery	ON: Master battery OFF:Slave battery
G	Link IN Link OUT	For internal and external communication	

H	ADD	Used to set the RS485 baud rate and inverter protocol choosing	
I	RUN	Used to show battery is in running status when lighting or flashing	
J	ALM	Used to show battery Alarm/Protection status	
K	SOC	Used to show battery real-time SOC	
L	Power switch	Used to Power on/off battery	
M	Negative terminal	Used to connect the inverter/charger	
N	Mounting ear	Used to fix with rack or cabinet	

### 3.3.3.1 D: Dry contact

PIN	Type	
1	NC Output1, Charge enable/disable signal (Rated current 1A)	When the battery reaches the charging /discharging MOS off state (the charging/discharging circuit is cut off). The BMS sends a control signal to the relay corresponding to the dry contact to keep the dry contact on.
2		
3	NC Output2, discharge enable/disable signal (Rated current 1A)	
4		
5	Passive INPUT signal Rapid Shut Down function for US	After receiving the two-pin Rapid Shut Down signal, the master BMS sends the Rapid Shut Down signal to the slave BMS, and the master and slave BMS cut off the circuit at the same time. After the two-pin shorting is removed, the master and slave BMS return to normal.
6		

## NOTICE

Pin1 on the left

### 3.3.3.2 G: Link IN / Link OUT

Port	Pin No.	Definition	Remarks
Link IN	1	RS485-B1	1.Used to connect with external devices to establish communication. 2.Used to connect with upper battery pack Link OUT.
	2	RS485-A1	
	3	SGND	
	4	CAN-H	
	5	CAN-L	
	6	SGND	
	7	RS485-A1	
	8	RS485-B1	
Link OUT	1	RS485-B2	Used to connect with downward battery pack Link IN.
	2	RS485-A2	
	3	SGND	

	4	CAN-H	
	5	CAN-L	
	6	SGND	
	7	RS485-A2	
	8	RS485-B2	

## ⚠ NOTICE

The BMS contains the CANBUS 120Ω resistance, and the BMS will automatically connect or disconnect the resistance according to the need. It is not necessary to connect the 120Ω resistance when connecting the CANBUS

### 3.3.3.3: ADD (DIP addressing)

DIP							Remarks
	RS485 baud rate	Undefined			Protocol		
1	2	3	4	5	6	7	
	ON: 115200	Reserved for multiple cluster parallel and other future function			0	0	Protocol ID1
	OFF: 9600				1	0	Protocol ID2
reserved	<b>Keep all battery the same setting</b>	<b>Keep default setting</b>			0	1	Protocol ID3
					1	1	reserved

Note: only master battery needs to set the Protocol ID, keep all slave battery default setting.

Protocol ID	CANBUS Connection	RS485 Connection
1	Victron/SMA/Studer Innotec/Sofar	Voltronic/RCT/MPP/Alpha outback
2	Sol-Ark/Solis/Goodwe/Deye/Growatt/SAJ/LUXPOWER Megarevo/INVT/Sermatec/TBB/MUST/Sunsynk	
3	Schneider	

## ⚠ NOTICE

Fail to follow the DIP switch setting will cause the communication fault between battery and inverter, for more detail setting with different inverter/charger, please contact your supplier or RUIXU for consultation.

### 3.3.3.4 RUN/ALM/SOC

Mode	Normal/Alarm/Protection	RUN	ALM	LED indicator				description
		●	●	●	●	●	●	
Shutdown	Dormancy	OFF	OFF	OFF	OFF	OFF	OFF	ALL OFF
Standby	Normal	FLASH1	OFF	According to battery state of charge				Standby
	Warning	FLASH1	FLASH3					Low voltage
Charge	Normal	ON	OFF	According to battery state of charge (highest SOC LED: FLASH2)				All alarm except the over charge
	Warning	ON	FLASH3					
	Over-current	OFF	ON	OFF	OFF	OFF	OFF	Stop charging
Discharge	Normal	FLASH3	OFF	According to battery state of charge				
	Warning	FLASH3	FLASH3					
	Under voltage	OFF	FLASH3	OFF	OFF	OFF	OFF	Stop charging
	Over current, short circuit	OFF	ON	OFF	OFF	OFF	OFF	Stop charging
Temperature	Protection	OFF	ON	OFF	OFF	OFF	OFF	Stop charging/discharging
Failure	Cell failure NTC failure Sensor failure MOS failure Charger HV failure	OFF	ON	OFF	OFF	OFF	OFF	Stop charging/discharging

FLASH Type	ON	OFF
FLASH1	0.25S	3.75S
FLASH2	0.5S	0.5S
FLASH3	0.5S	1.5S

### 3.4 Protection

Items	Description	Remark
Charge End Cell/PACK high-voltage	The BMS will stop charging if any cell or PACK voltage reach the protection value and it will be auto-released only when both Pack and cell voltage back to the release voltage range or there is efficient discharge current	
Discharge End	The BMS will stop discharging if any cell or PACK voltage is	Can Automatic



Cell/PACK low-voltage	under the protection value and it will be released only when all the cell voltage back to the release voltage range or there is efficient charge current	recovery. Please charge timely, otherwise it may be in Low-power mode to be over-discharged.
High temperature	The BMS will stop charging or discharging or both if any cell/environment/MOS temperature is beyond the range.	Automatic recovery
Low temperature	The BMS will stop charging or discharging or both if any cell/environment/MOS temperature is under the range.	Automatic recovery
Charge over-current	The BMS will stop charging when the charging current is higher than the protection value. And it will release from the protection when the system delays time is met.	Automatic recovery. If locked after three consecutive times, manual intervention is required.
Discharge over-current/ Overload	The BMS will stop discharging when the discharging current is higher than the protection value. And it will release from the protection when the system delays time is met	Automatic recovery. If locked after three consecutive times, manual intervention is required.
Short-circuit/Reversed	Short-circuit and Reversed polarity protection happened	Charge to release Manual reset
Temperature, Voltage, Current sensor failure	Enter the failure mode, manual intervention is required no charging and discharging.	Manual intervention
dormancy mode	After reaching a certain condition, it will be in the dormancy mode	Recoverable

## CAUTION

Please re-charge the battery via solar, grid/generator or other energy source within 24h if the battery is over discharged.

## NOTICE

Manually short-circuit and reverse the battery will void the warranty.

## 4 Installation

### 4.1 Preparation

#### 4.1.1 Safety Compliance

The system installation must be finished by qualified person(s), During the whole installation process, please strictly follow the local safety regulations and related operating procedures.

#### 4.1.2 Environment

The operating environment shall meet the following requirements:

Category	Description
Working temperature	-10°C-50°C (maximum operating range) 15°C-30°C (optimal temperature)
Relative humidity	5%~90%, No condensation
Altitude	<3000m
Safety requirement	<ul style="list-style-type: none"> <li>Do not expose the battery to direct sunlight, rain and snow.</li> <li>Do not place the battery within children/pet touchable area.</li> <li>Do not place the battery near heat source and flammable material</li> <li>Do not place the battery in a closed place where the ventilation is not available.</li> <li>Do not drop, deform, impact, cut or spearing with a sharp object.</li> <li>Do not put heavy things on battery.</li> <li>Do not disassemble the battery without Manufacturer's permission.</li> <li>No conductive dust and water or other liquid to contact battery.</li> <li>Follow the emergency measure if there is water invasion or electrolyte and gas leakage.</li> <li>Contact your supplier within 24 hours if any product failure happens.</li> </ul>

#### 4.1.3 Tools



Tools	
Screwdriver (slot, cross)	Multi-meter
Wrench	Clamp meters
Diagonal pliers	Insulating tape
Needle nose pliers	Thermometer (observe the installation environment)
Clamping pliers	Anti-static bracelet
Wire stripper	cable ties

## 4.2 Inspection

### 4.2.1 Unpack precautions

- Please load and unload it in accordance with the specified requirements to prevent sun and rain when you receive the equipment.
- Please check and confirm the goods (such as quantity, appearance, etc.) according to the "scope of delivery " before unpacking.
- Do light take and put during unpacking process to protect the surface coating of the object;
- Please record and feedback to the manufacturer if the inner packing is damaged after unpacking.

### 4.2.2 Scope of delivery

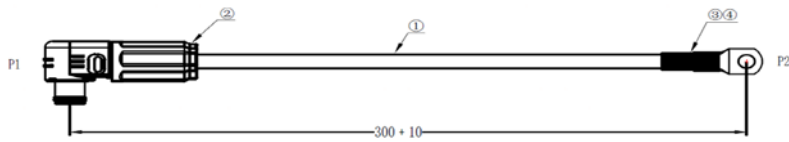
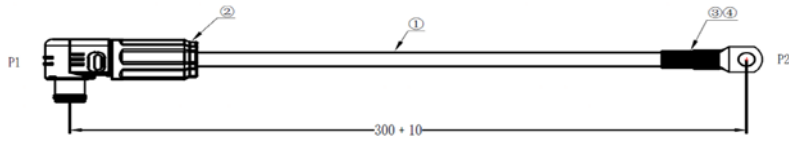
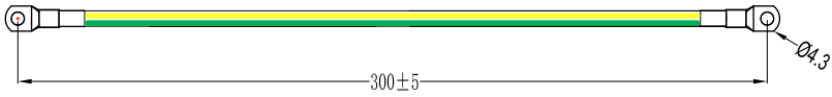
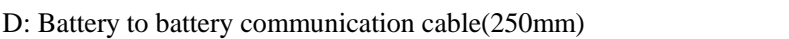
General materials		
		
Battery Pack *1pcs	Manual *1pcs	Warranty document *1pcs
Optional materials		
Type	Matirial detail	Qty.
Rack mounted kits (Packed with general materials)	A: Battery to Busbar positive cable(4AWG 300mm RED) 	1pcs
	B: Battery to Busbar negative cable(4AWG 300mm BLACK) 	1pcs
	C: Battery to battery grounding cable(300mm) 	1pcs
	D: Battery to battery communication cable(250mm) 	1pcs

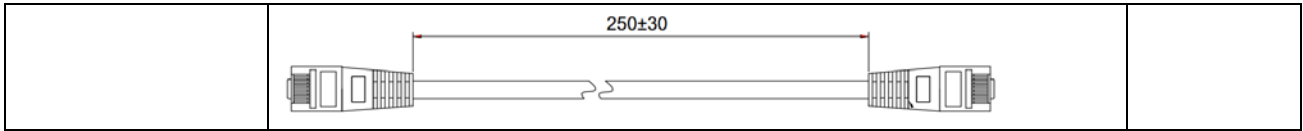

### 4.2.3 External cable kits

Cables connected to inverter or junction box belongs to an External Cable kits, **NOT include** in battery carton. Customers need buy it separately, the information are as below.

Type	Detail	Qty.								
External bus cable (2000mm)		2pcs								
Grounding cable		1pcs								
Inverter communication cable (1 out of 3)		1pcs								
	Version I(CAN):	<table border="1"> <tr> <td>Pin 4</td> <td>Pin 4</td> </tr> <tr> <td>Pin 5</td> <td>Pin 5</td> </tr> </table>	Pin 4	Pin 4	Pin 5	Pin 5				
	Pin 4	Pin 4								
	Pin 5	Pin 5								
	<table border="1"> <thead> <tr> <th>Battery side pin</th> <th>Inverter side pin</th> </tr> </thead> <tbody> <tr> <td>Pin 4</td> <td>Pin 7</td> </tr> <tr> <td>Pin 5</td> <td>Pin 8</td> </tr> <tr> <td>Pin 6</td> <td>Pin 3</td> </tr> </tbody> </table>	Battery side pin	Inverter side pin	Pin 4	Pin 7	Pin 5	Pin 8	Pin 6	Pin 3	1pcs
Battery side pin	Inverter side pin									
Pin 4	Pin 7									
Pin 5	Pin 8									
Pin 6	Pin 3									
Version II(CAN):										
Version III(RS485):	<table border="1"> <tbody> <tr> <td>Pin 1</td> <td>Pin 3</td> </tr> <tr> <td>Pin 2</td> <td>Pin 5</td> </tr> <tr> <td>Pin 3</td> <td>Pin 8</td> </tr> </tbody> </table>	Pin 1	Pin 3	Pin 2	Pin 5	Pin 3	Pin 8	1pcs		
Pin 1	Pin 3									
Pin 2	Pin 5									
Pin 3	Pin 8									

For inverter communication PIN definition detail, please check [Appendix I](#)

## NOTICE

Keep the unused cable pins NULL to avoid affecting the closed loop communication.

## NOTICE

A ground connection of communication cable may be required from some inverters, please follow the rules from inverter manufacture.

### 4.3 Start Installation

#### Qualified person

##### 4.3.1 Remainder

Please check again the following conditions or equipment whether meet the requirements before installation:

- Check if there's enough space for installation, and if the load-bearing capacity of the bracket or cabinet meets the weight requirements
- Check whether the power cable pair(s) used meets the maximum current requirement for operation;
- Check whether the overall layout of power supply equipment and batteries at the construction site is reasonable;
- Check whether the installer is wearing anti-static wristband
- Check whether there're two people on the construction site for installation work
- Check if there's potential risks at location of installation site, e.g flooding, sun exposure, corrosion, and salt spray

##### 4.3.2 Procedures

## CAUTION

Injuries may result if the product is lifted incorrectly or dropped while being transported or mounted.  
Wear suitable personal protective equipment for all work on the product.

## CAUTION

Ensure that no lines are laid in the wall which could be damaged when drilling holes.

## 4.3.2.1 Rack mounted

i.	Take the battery pack out from carton.
ii.	Get the Rack ready and place it horizontally at a reasonable location.
iii.	Place the battery on the rack or cabinet tray via manual-lift, Insert the screws and fasten the battery to the rack or cabinet.
iv.	Finish the cable connection

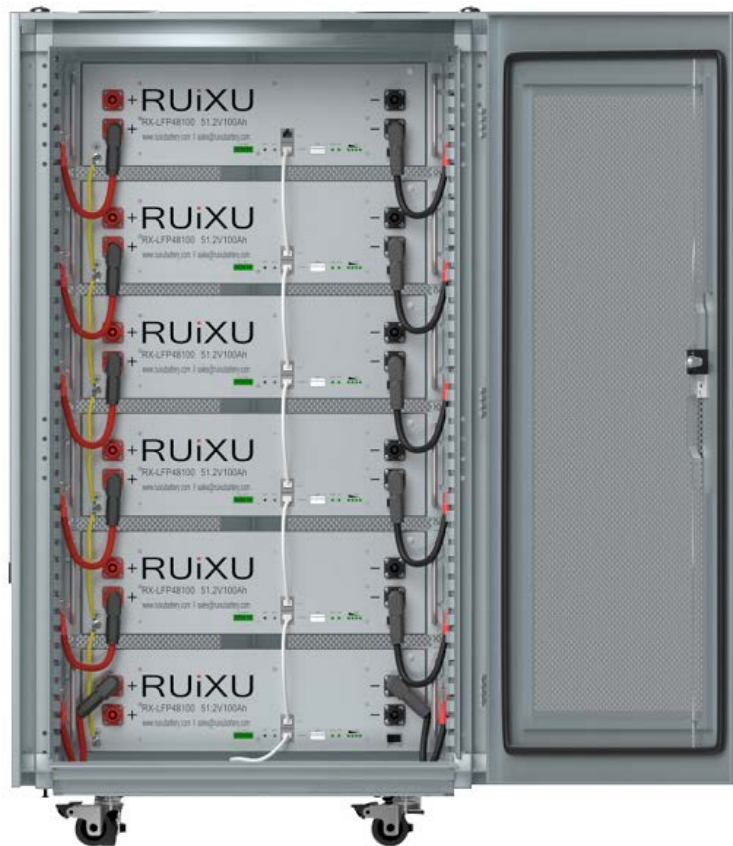

### NOTICE

ANY others installations, please avoid the battery directly contacting the ground and avoid of high salinity, humidity to prevent the product from rusting and corrosion.

## 5. Cable connection and commissioning

 Qualified person

## 5.1 Get battery ready

5.1.1 Ensure all the battery is in OFF mode, and confirm the installation is tighten and stable.

5.1.2 Check the number and specification of cable kit accessories are correct according to the Scope of delivery item, if you are making cable yourself, please follow manufacturer's requirements.

5.1.3 Switch on all battery individually, check whether there is any alarm/protection information, if yes, turns to troubleshooting. Then switch off all batteries.

## 5.2 Grounding cable connection

5.2.1 Take out the grounding screw on the battery panel, and get the cable conductor through it.

5.2.2 Fix them together, with a cylinder screwdriver and tighten it.

5.2.3 Connect the grounding cable with next battery module.

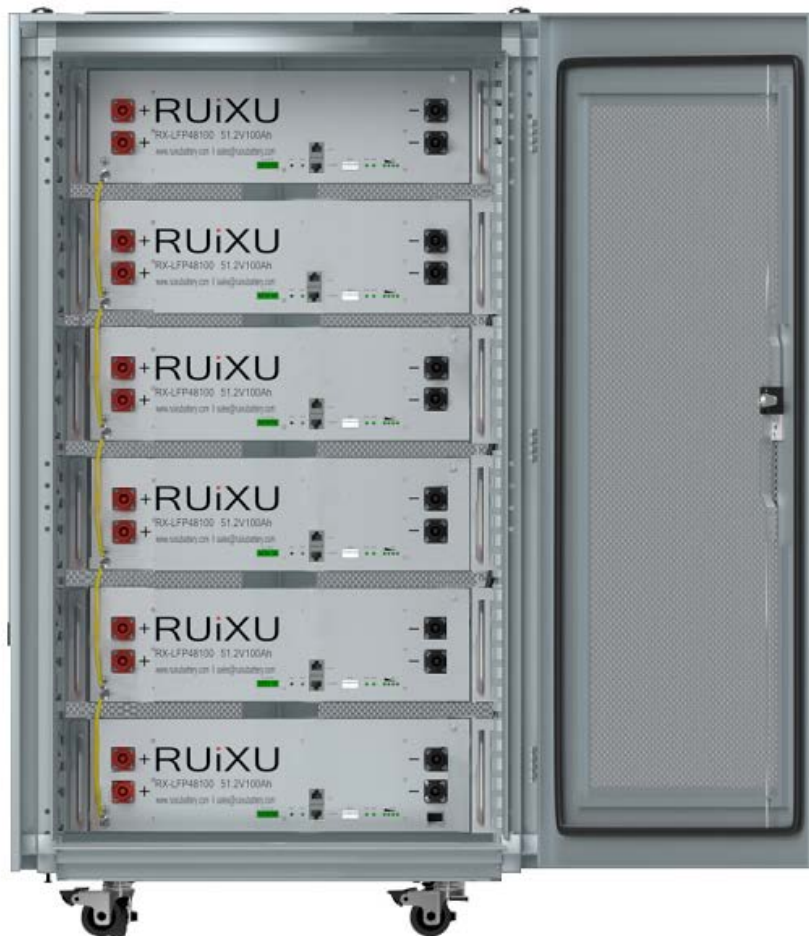

## 5.3 Communication cable connection

5.3.1 Take out battery to battery communication cable.

5.3.2 Confirm the location of Master battery, insert the RJ45 plug into the Link Out port and connect the other side to next battery Link IN port, daisy chained all batteries.

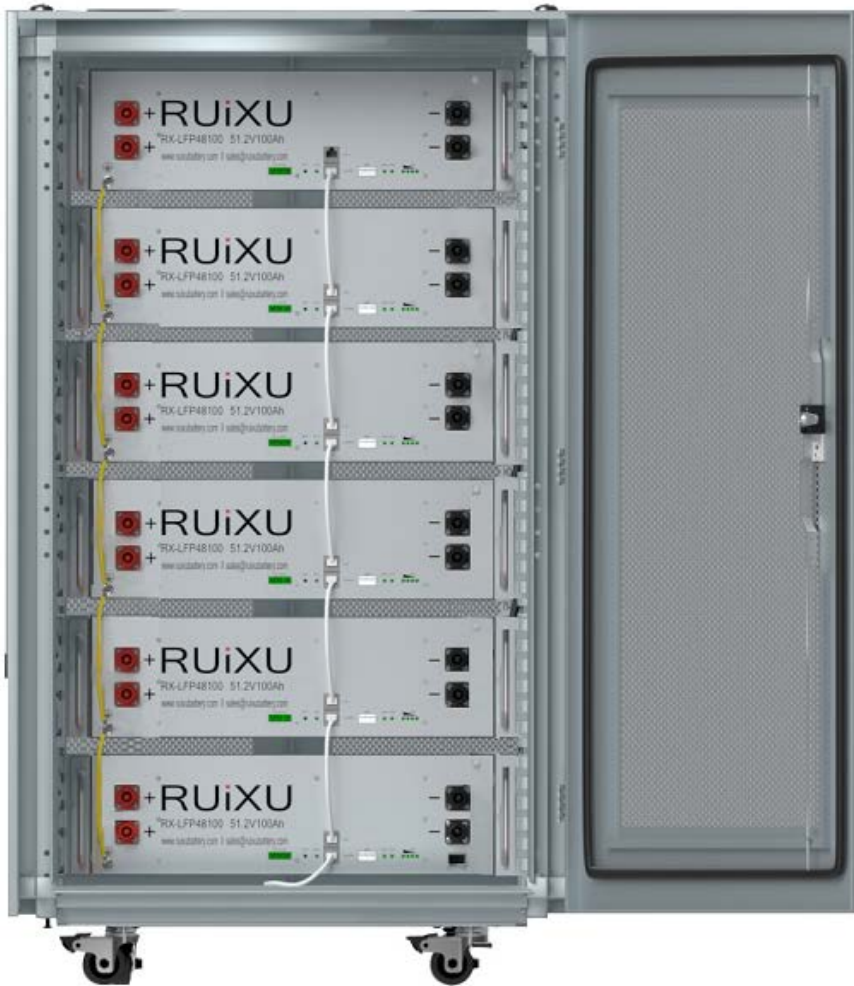



## 5.4 DC power cable connection

5.4.1 Take out battery to battery power cable.

5.4.2 Insert the Plug into the power socket until you hear the snapping sound.

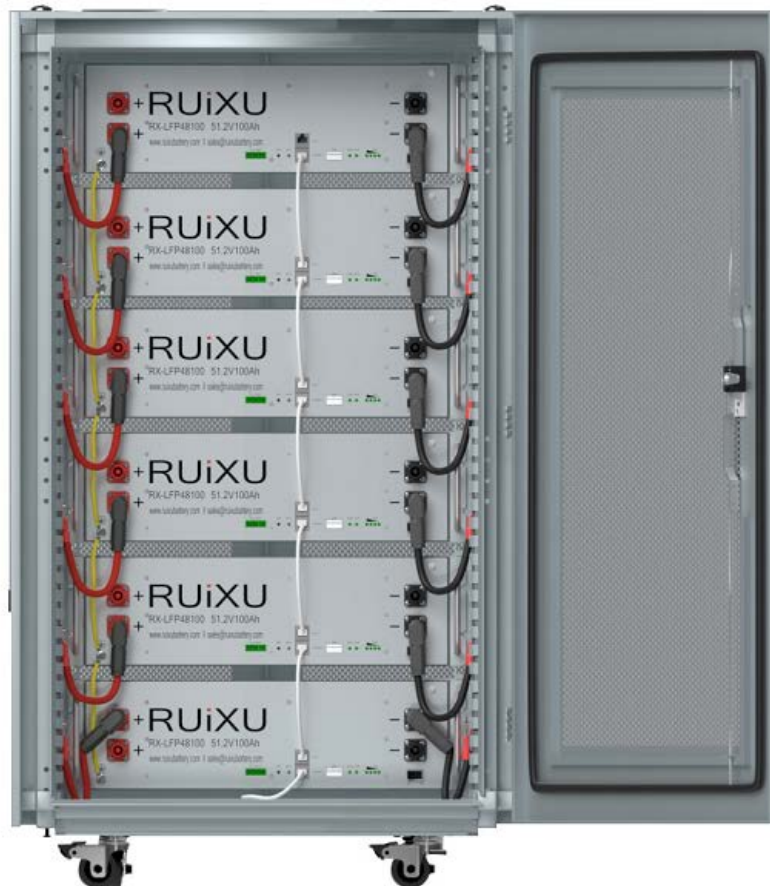

## 5.5 Connecting with inverter

### ⚠ CAUTION

Confirm inverter AC input and PV input is disconnected before wiring connection, and the DC/ signal switch of inverter/charger is in off status.

5.5.1 Connecting Master battery Link IN port with inverter CAN or RS485 communication port via inverter communication cable.

5.5.2 Connecting battery OUTPUT (+) with inverter battery INPUT (+), battery OUTPUT (-) with inverter battery INPUT (-), an external disconnection breaker between battery system and inverter is recommended, choose the corresponding power cable pair and wiring them correctly.

Note:

## ⚠ NOTICE

Choose the suitable disconnection breaker considering the inverter power/current, rated voltage, tripping characteristic etc.

**Wiring diagram allowed:**

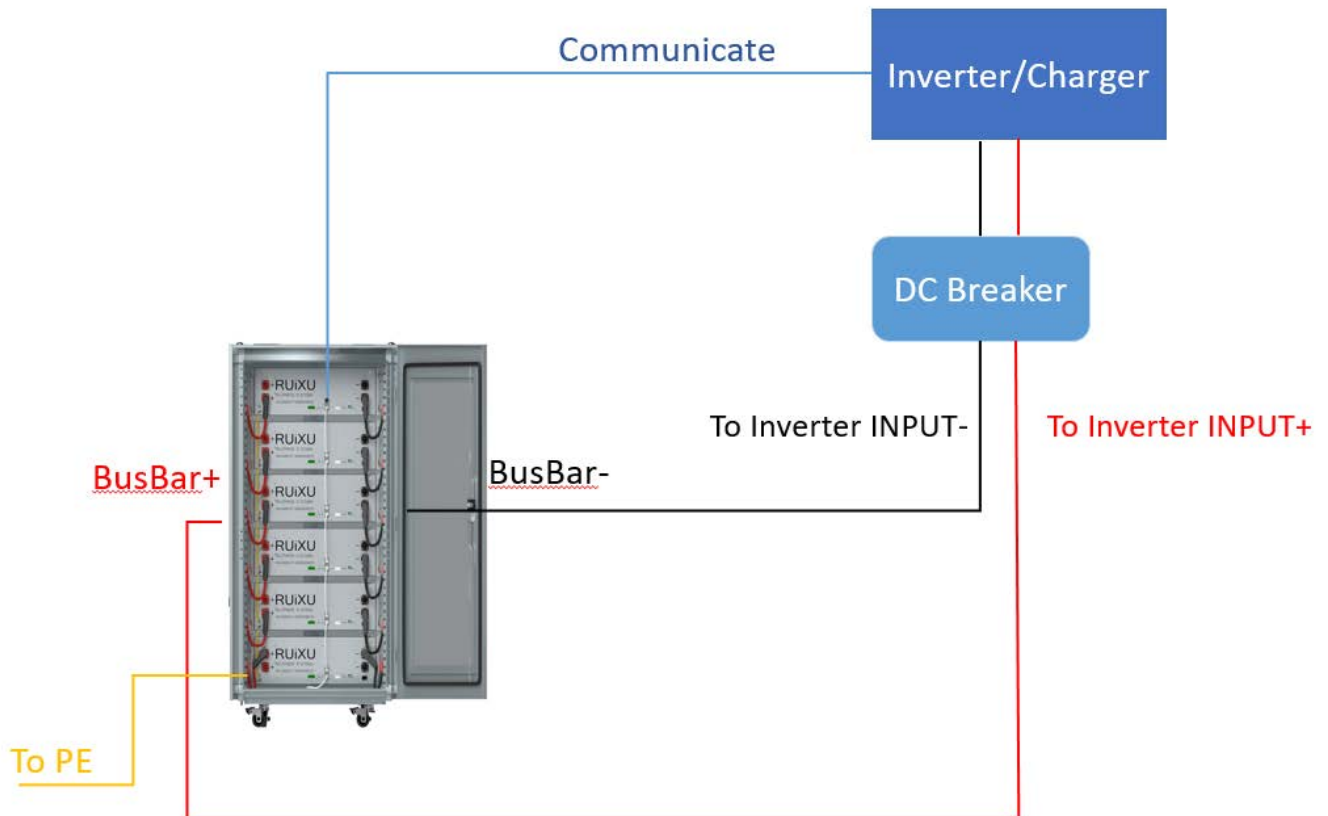

## ⚠ NOTICE

The maximum communication cable length is required to be less than 15m between inverter/charge and battery.

The maximum power cable length is suggested to be less than 10m between inverter/charge and battery.

For other type of installation, please also follow the rules above to wiring your system.

## CAUTION

The maximum tolerance current of each power cable and terminal is 125A, 100A for continuously is suggested, please use corresponding number of power cable pairs according to the field configuration and local connection requirements, standards, and directives.

## 5.6 Commissioning

5.6.1 Set the DIP address of the Master battery (and the Slave battery if there is any RS485 baud rate change).

5.6.2 Switch on all battery modules, wait 1 minute, make sure that only M/S led is on Master battery.

5.6.3 Turn on the breaker between the inverter and battery if there is any, then turn on the inverter/charger isolator.

5.6.4 Finish the setting on inverter/charger or any other control devices, if everything is correct, you are ready to use the system.

## CAUTION

If your system is an back-up or off-grid system, make sure your configuration can cover the worst situation to avoid battery to be over-discharged.

## 5.7 Switch off battery

5.7.1 Turn off the inverter.

5.7.2 Turn off the disconnection breaker if there is any.

5.7.3 Turn off all batteries signal switch.

## 5. Troubleshooting

Items	Solution	Measure
Unable to start	<ol style="list-style-type: none"> <li>1. Switch on battery and press RESET 6s to observe whether the battery can be started.</li> <li>2. Charge the battery use a charge or inverter to provide 54~57.6V voltage and observe it can be started.</li> </ol>	<p>If the abnormal status still alive after above steps, please contact your supplier.</p> <p>If there is any other situation(s) excluding in this table, turn off the fault battery, contact your supplier.</p>
Unable to charge	<ol style="list-style-type: none"> <li>1. Check whether the cable connection between the battery and the inverter/charger is correct.</li> <li>2. Check whether the inverter/charger setting is correct.</li> <li>3. Check whether the battery is in charge protection mode, if yes, try to discharge the battery.</li> </ol>	
Unable to discharge	<ol style="list-style-type: none"> <li>1. Check whether the cable connection between the battery and the inverter/charger is correct</li> <li>2. Check whether the battery occurs short circuit, reverse connection, pre-charge failure during connection inverter etc.</li> <li>3. Check whether the battery is in discharge protection mode, if yes, try to charge the battery.</li> </ol>	
High/Low temperature	<ol style="list-style-type: none"> <li>1. Stop the battery system for a while, check whether the installation location temperature meet the requirement.</li> <li>2. Avoid continuous full charging and discharging</li> </ol>	
High current	Check the configuration and parameters setting on the inverter/charger is correct.	
ALM always on	Turn off all the batteries, and remove the fault battery from the system.	
Communication fail	<ol style="list-style-type: none"> <li>1. Check the communication cable type is correct and is contacted well.</li> <li>2. Check the DIP switch setting is correct.</li> <li>3. Check the inverter protocol related setting is correct.</li> <li>4. Check both battery and inverter are working properly.</li> </ol>	

### NOTICE

Please restart after software upgrade.

## 6. Transport, Storage

- Do not violently shake, impact or squeeze, and prevent sun and rain during the transportation.
- Do light take and put and strictly prevent falling, rolling, and heavy pressure during loading and unloading.
- The battery should be placed in a dry, clean, dark, and well-ventilated indoor environment for long-term storage, and the recommended storage temperature range is 15~30°C.
- No harmful gases, flammable and explosive products and corrosive chemical substances in the storage location.
- The batteries should be stored and transported in close to 50% SOC, do not store over 80%SOC for long time.
- If do not use for a long time, the battery needs to be charged every 6 months.
- No fall down, no pile up over 6 layers, and keep face up.

## 7. Disposal of battery

Disposal of battery must comply with the local applicable disposal regulations for electronic waste and used batteries, please review your local Battery recycling or management regulations or contact RUIXU for more information.

## Appendix I

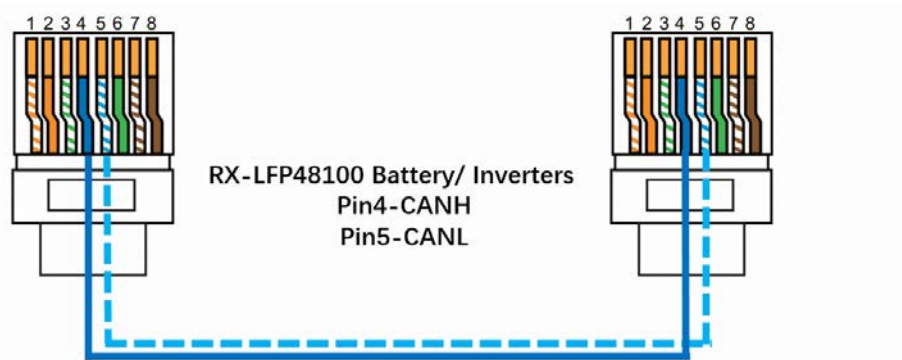

Definition	Battery Link IN port	Inverter communication	Cable suggest
CAN H	Pin4	Pin4	Version-I(CAN)
CAN L	Pin5	Pin5	

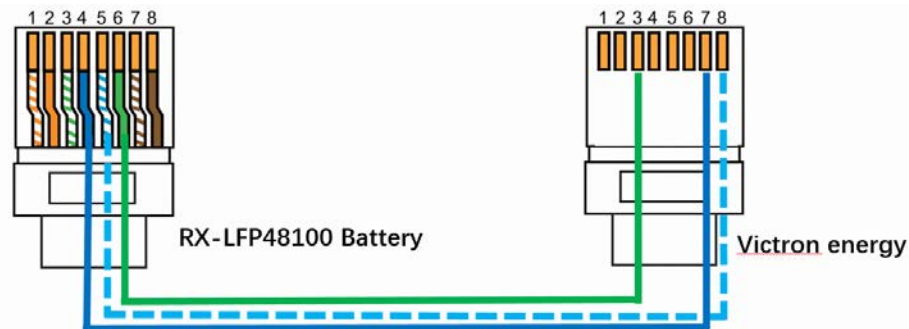

Definition	Battery Link IN port	Inverter communication	Cable suggest
CAN H	Pin4	Pin7	Version-II (CAN)
CAN L	Pin5	Pin8	
GND	Pin6	Pin3	

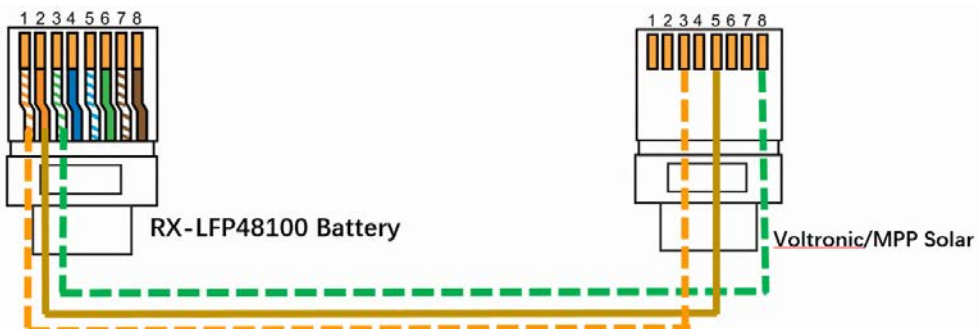

Definition	Battery Link IN port	Inverter communication	Cable suggest
RS485-B	Pin1	Pin3	Version-III (RS485)
RS485-A	Pin2	Pin5	
GND	Pin3	Pin8	



