



P/N :GS02-150WS**AT1A1**-**abcde**

Note:

GS02 = Product series,LED Garden Light

150W = Rating Power

S= Driver manufacturer, SOSEN

A = LED manufacturer, Hongli 2835

T1 = Diffuser light angle type, 60°

A1 = Version number

a= Housing colors, BH = Black、WH=White、BR=Brown、
or Customized

b= P or blank represent Photocell or None Photocell

c= S or blank

represent Surge protector or None Surge protector

d= M or None

represnet Motionsensor or None Motionsensor

e = CCT, 40=4000K, 45=4500K,

50=5000K, 57=5700K



DIMENSIONS

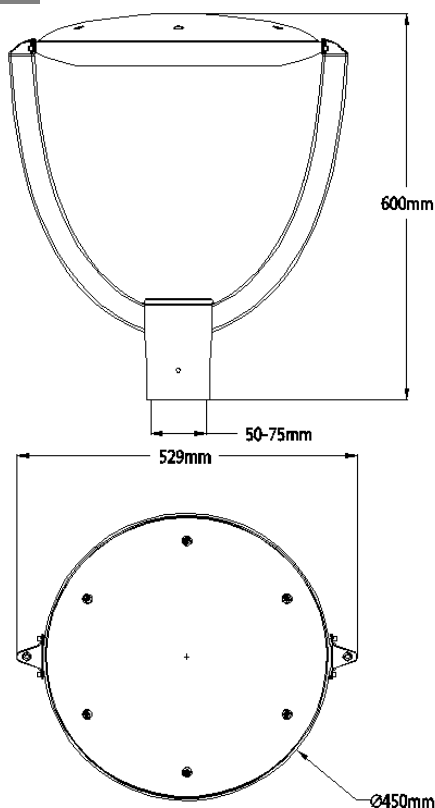

ADVANTAGE

- UL cUL certificate.
- IP65 driver, input voltage 100-277VAC.
- No UV or IR in the beam.
- Easy to install and operate.
- Energy saving, long lifespan.
- Light is soft and uniform, safe to eyes.
- Instant start, NO flickering, NO humming.
- Green and eco-friendly without mercury.

APPLICATION

- ◆ City Slow Lane、Narrow Lane,
- ◆ Residential Area, Plaza,
- ◆ Sightseeing Area, Village Road and so on.

SPECIFICATIONS

OPTICAL	Input Power	150W
	Lumen	17700-19200LM
	Lumen Efficacy	118-128 LM/W
	Color Temperature	4000K,4500K, 5000K, 5700K
	CRI	>80
	Viewing Angle	60Degree
ELECTRICAL	Input Voltage	100-277VAC 50/60Hz
	PF	≥0.9
	THD	≤20%
	Driver Model	China Brand Driver
MATERIALS	LED Type	SMD2835 (0.5W)
	LED QTY	465 PCS
	Housing	Aluminum Alloy
	Housing Color	Black、White、Brown、or Customized
	Cover	PC lens
	Waterproof Rating	WET (IP65)
OTHERS	Operating Temperature	-20℃ TO 45℃
	Operating Humidity	20%-90% RH
	Storage Temperature	-30℃ TO 80℃
	Storage Humidity	10%-95% RH
	Warranty Time	5 Years

PACKAGE

	Size	Qty / Carton	Net Weight / Carton	Gross Weight / Carton
Outer box	835 x 585 x155 mm	1 PCS	6.5 KG	8.5 KG

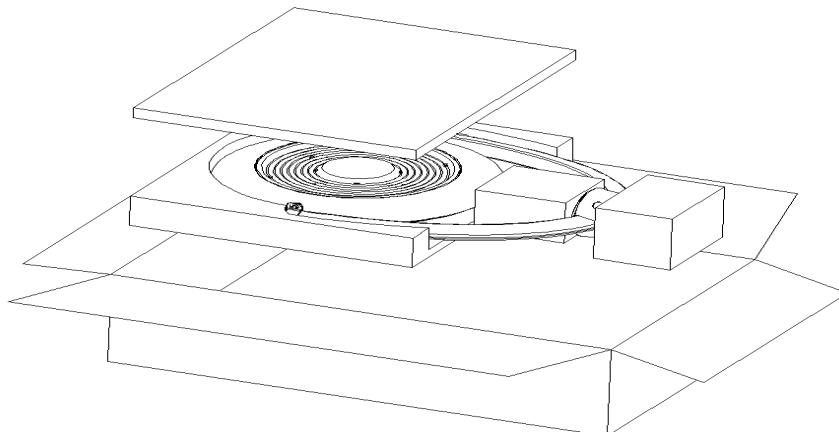

LIGHT DISTRIBUTION TESTING PARAMETERS

Luminaire Property

Luminaire Manufacturer:
Voltage: 120.5 V
Power: 150.90 W

Current: 1.263 A
Power Factor: 0.991

Photometric Results

IES Classification: Type II
Total Rated Lamp Lumens: 18391.7 lm
Efficiency: 100%
Upward Ratio: 1%
Central Intensity: 7601.88 cd
Pos of Max. Intensity: H315 V26

Longitudinal Classification: Very Short
Measurement Flux: 18391.7 lm
Downward Ratio: 99%
Luminaire Efficacy Rating (LER): 121.93
Max. Intensity: 7776.61 cd

Luminous Intensity Distribution Curve

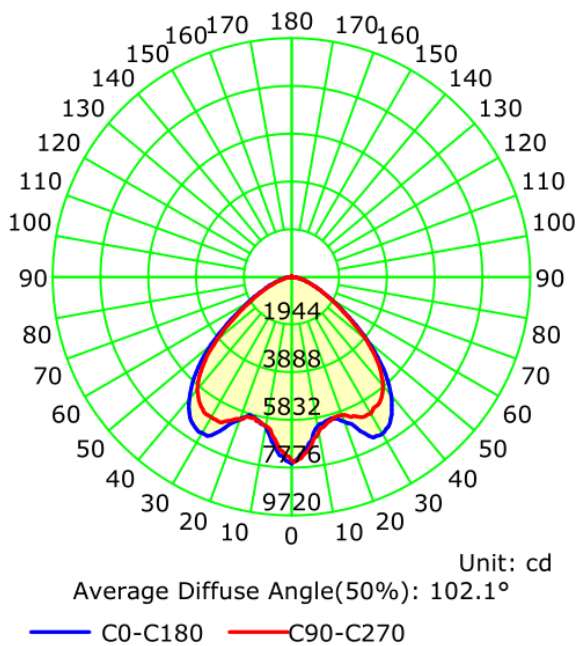

Illuminance at a Distance

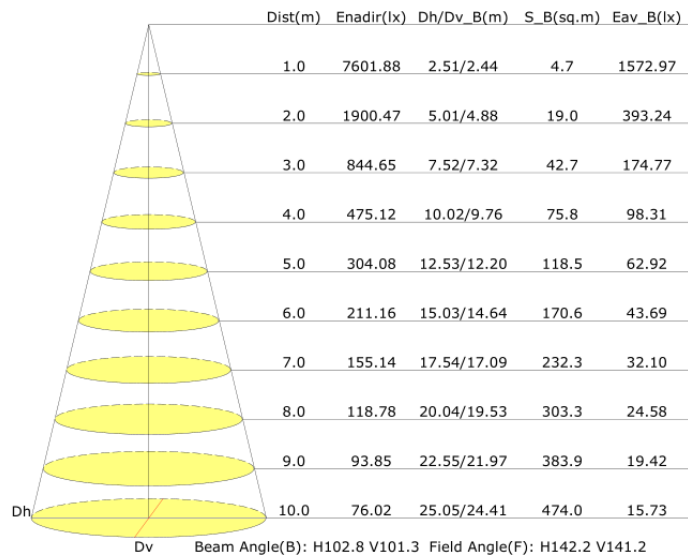

NOTICE FOR USER

- Please turn off power before install or change assembly parts.
- The input voltage and lamps should be matched, after connecting the power line, Please make sure the wiring section is insulated.
- No-professionals, must not install and disassemble the lamps.

TROUBLE SHOOTINGS

Troubles	Check points
Flickering of the light	Turn off the power and turn on again in 3 minutes. If same phenomena occur, then call agencies.
Out of working	Please check the connection.