

TECHNICAL DATA SHEET

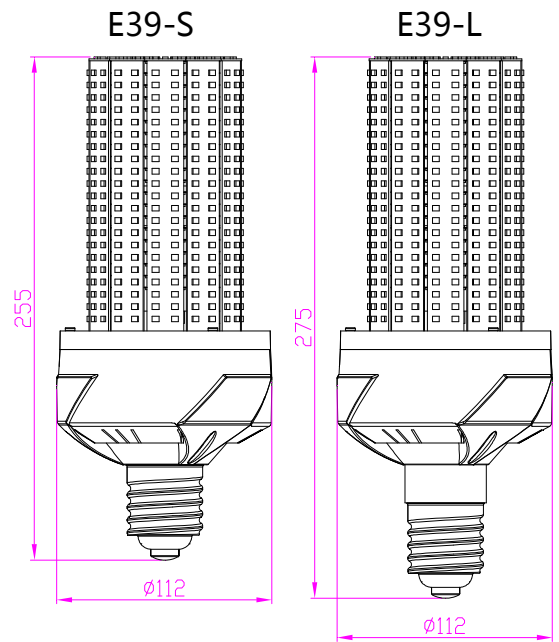

E39-S: Short Plastic Housing

E39-L: Longer Plastic Housing

NAME: LED Corn Light

P/N: CL-80WB2

Advantage

- UL、CUL certificate
- E39 lamp base
- Warm / Natural / Cool / Cold white
- 360 degree lighting, high CRI.
- Can be with Longer or short Plastic Housing.
- Big heat sink, double SUNON fans.
- Internal driver, input voltage AC100-277V.
- New style and high efficient wide-range input.
- Long lifespan and good heat dissipation.
- Direct replacement for Metal Halide, Easy Installation.
- Fits many different fixtures to replace traditional lamps.



Application

Widely used in supermarket, warehouse, garage, home, office, hotel, hospital, school, street, garden etc.

TECHNICAL DATA SHEET

PRODUCT SPECIFICATIONS	
Product name	LED Corn Light
Light Type	Corn Light
Part No	CL-80WB2
Dimension	Φ112*255 MM(E39-S)、Φ112*275 MM(E39-L)
Technical Characteristic	
Color temperature	2700-6500K
CRI	> 80
Lumen	10800-11600 LM
Lumen Efficacy	135-145 LM/W
Input Power	80 W
Viewing Angle	360 degree
Input Voltage	AC100-277V 50/60Hz
PFC	>0.9
Equivalent	150W CFL , 250W MHL/HPS/HID
Waterproof Rating	IP40
MATERIALS	
LED Brand	EPISTAR
LED Type	SMD2835
LED QTY	560 PCS
Housing	PC+AL
Housing color	White+Grey
OTHERS	
Operating Temperature	-20°C TO 45°C
Operating Humidity	20%-70% RH
Storage Temperature	-30°C TO 80°C
Storage Humidity	10%-75% RH
Application	Indoor/Outdoor
Safety Certification	UL、CUL
Warranty Time	5 Years

TECHNICAL DATA SHEET

Remark: The testing data comes directly from the product test.

DATA OF LAMP		PHOTOMETRIC DATA Eff: 148.29 lm/W			
MODEL		I _{max} (cd)	1238	S/MH (C0/180)	2.74
NOMINAL POWER (W)	80	LOR (%)	100.0	S/MH (C90/270)	2.73
RATED VOLTAGE (V)	120	TOTAL FLUX (lm)	11817	η UP, DN (C0-180)	21.1, 28.6
NOMINAL FLUX (lm)	11816.8	CIE CLASS	DIFFUSE	η UP, DN (C180-360)	21.2, 29.0
LAMPS INSIDE	1	η up (%)	42.4	CIBSE SHR NOM	2.00
TEST VOLTAGE (V)	120	η down (%)	57.6	CIBSE SHR MAX	0.00

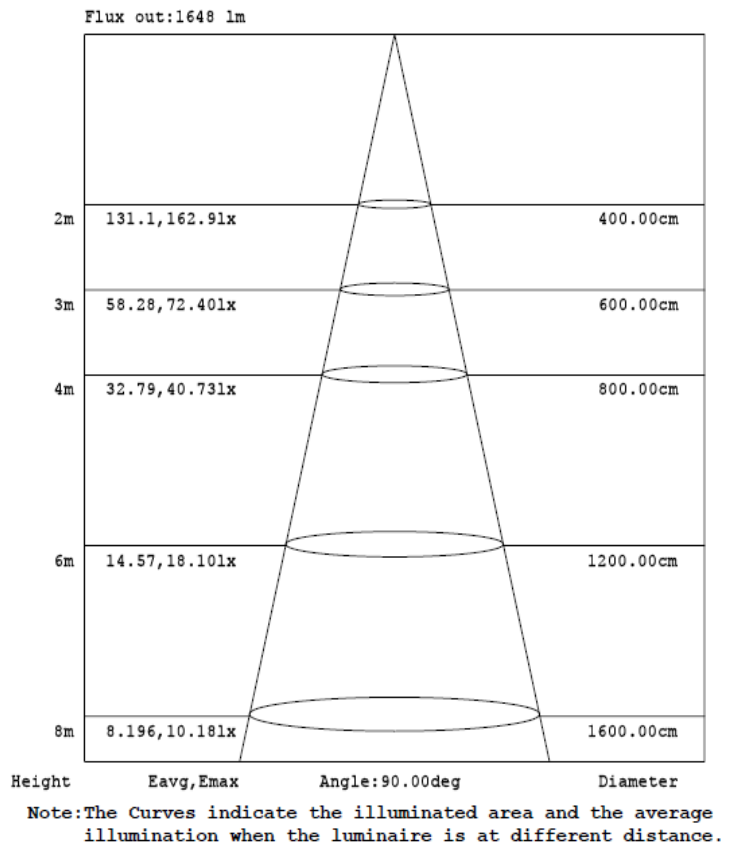
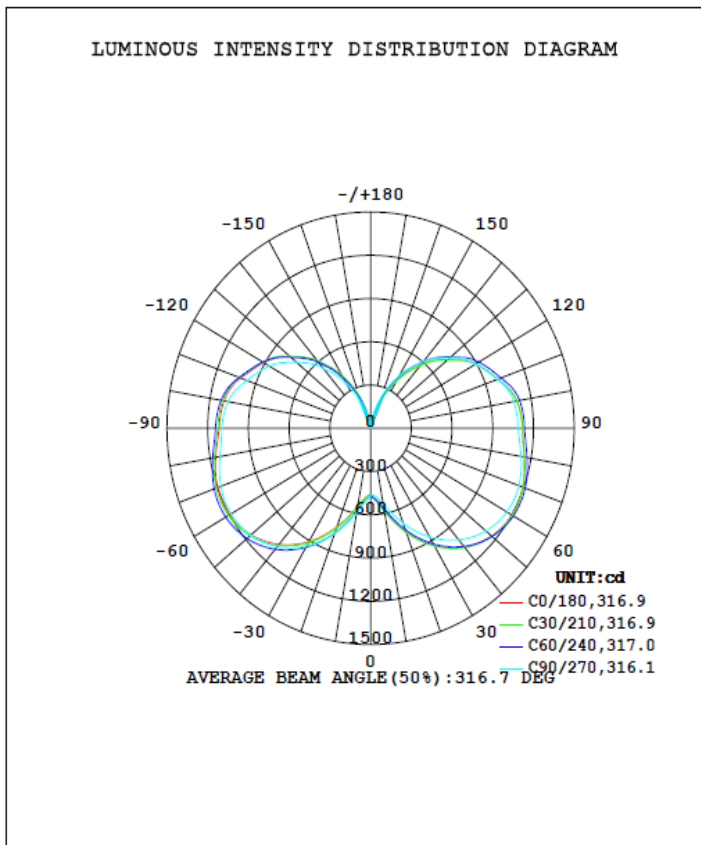

TECHNICAL DATA SHEET

Package

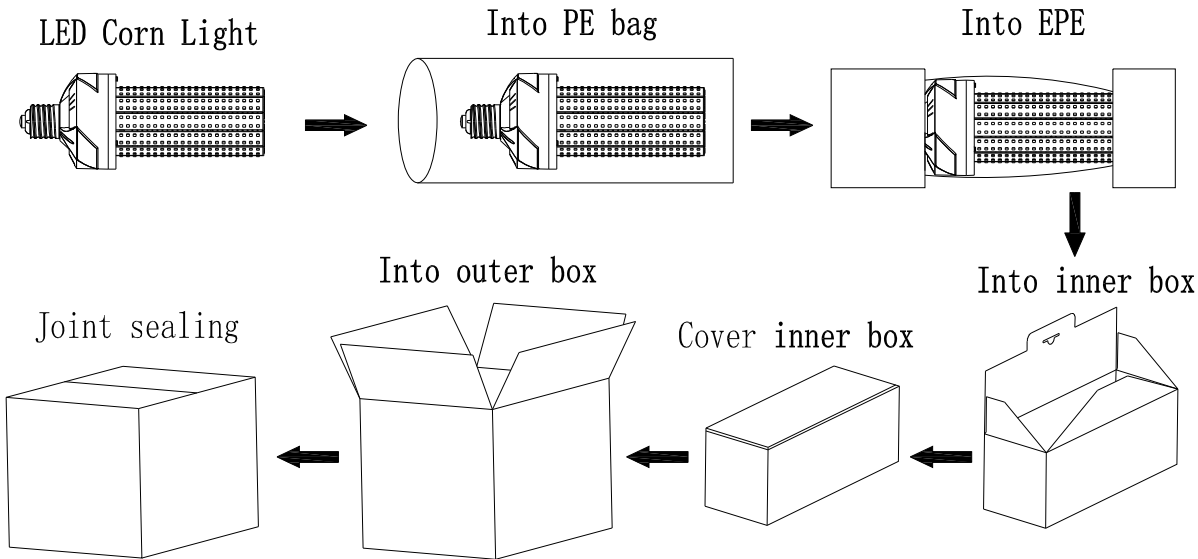

	Size (E39-S)	Size (E39-L)	Qty/ Carton	Net Weight/ Carton	Gross Weight/ Carton
Inner box	290*120*120 MM	310*120*120 MM	1 PC	0.59 KG	0.74 KG
Outer box	495*375*305 MM	495*375*325 MM	12 PCS	7.2 KG	10.0 KG

Notice For User

- Please turn off power before install or change assembly parts.
- The input voltage and lamps should be matched, after connecting the power line, please make sure the wiring section is insulated.
- Make sure to remove or bypass the ballast in the fixtures before install the lamps.
- Use in dry location only. Do not use with dimmers.
- Suitable for use in enclosed luminaires, min. lamp compartment dimensions: 390*200*200MM.
- No-professionals, must not install and disassemble the lamps.

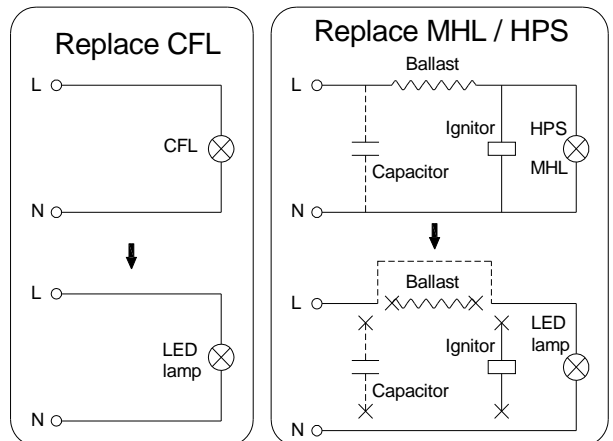

Trouble Shootings

Troubles	Check points
Flickering of the lamps	Turn off the power and turn on again in 3 minutes. If same phenomena occur, then call agencies
Out of working	Please check the connection