

TECHNICAL DATA SHEET

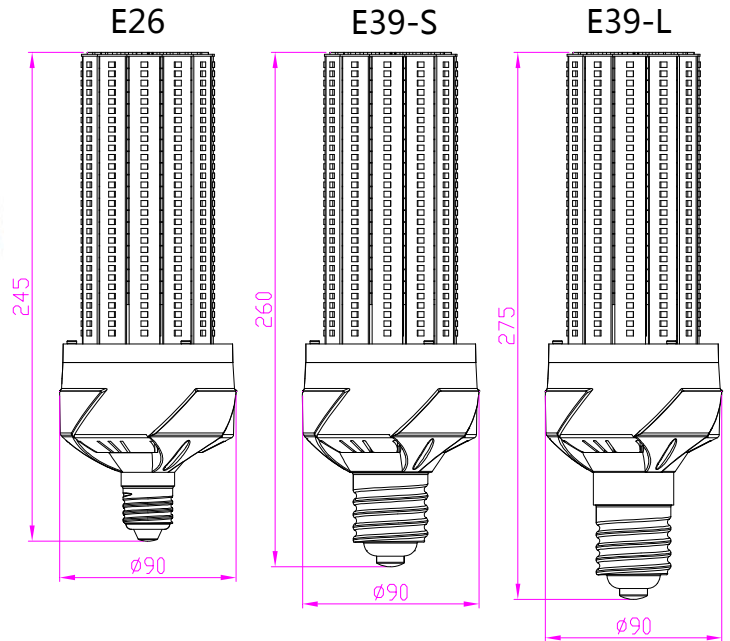

E39-S: Short Plastic Housing

E39-L: Longer Plastic Housing

NAME: LED Corn Light

P/N: CL-60WB2E26 / CL-60WB2E39

Advantage

- UL、CUL certificate
- E26、E39 lamp base
- Warm / Natural / Cool / Cold white
- 360 degree lighting, high CRI.
- E39 lamp can be with Longer or short Plastic Housing.
- Big heat sink, one SUNON fan.
- Internal driver, input voltage AC100-277V.
- New style and high efficient wide-range input.
- Long lifespan and good heat dissipation.
- Direct replacement for Metal Halide, Easy Installation.
- Fits many different fixtures to replace traditional lamps.



Application

Widely used in supermarket, warehouse, garage, home, office, hotel, hospital, school, street, garden etc.

TECHNICAL DATA SHEET

PRODUCT SPECIFICATIONS		
Product name	LED Corn Light	
Light Type	Corn Light	
Part No	CL-60WB2E26	CL-60WB2E39
Dimension	Φ90*245 MM	Φ90*260 MM(E39-S)、Φ90*275 MM(E39-L)
Technical Characteristic		
Color temperature	2700-6500K	
CRI	> 80	
Lumen	7800-8400 LM	
Lumen Efficacy	130-140 LM/W	
Input Power	60 W	
Viewing Angle	360 degree	
Input Voltage	AC100-277V 50/60Hz	
PFC	>0.9	
Equivalent	120W CFL , 175W MHL/HPS/HID	
Waterproof Rating	IP40	
MATERIALS		
LED Brand	EPISTAR	
LED Type	SMD2835	
LED QTY	400 PCS	
Housing	PC+AL	
Housing color	White+Grey	
OTHERS		
Operating Temperature	-20°C TO 45°C	
Operating Humidity	20%-70% RH	
Storage Temperature	-30°C TO 80°C	
Storage Humidity	10%-75% RH	
Application	Indoor/Outdoor	
Safety Certification	UL、CUL	
Warranty Time	5 Years	

TECHNICAL DATA SHEET

Remark: The testing data comes directly from the product test.

DATA OF LAMP		PHOTOMETRIC DATA Eff: 143.65 lm/W			
MODEL		I _{max} (cd)	835.4	S/MH (C0/180)	2.81
NOMINAL POWER (W)	60	LOR (%)	100.0	S/MH (C90/270)	2.80
RATED VOLTAGE (V)	120	TOTAL FLUX (lm)	8156.8	η UP, DN (C0-180)	21.5, 28.3
NOMINAL FLUX (lm)	8156.75	CIE CLASS	DIFFUSE	η UP, DN (C180-360)	21.7, 28.4
LAMPS INSIDE	1	η up (%)	43.2	CIBSE SHR NOM	2.00
TEST VOLTAGE (V)	120	η down (%)	56.8	CIBSE SHR MAX	0.00

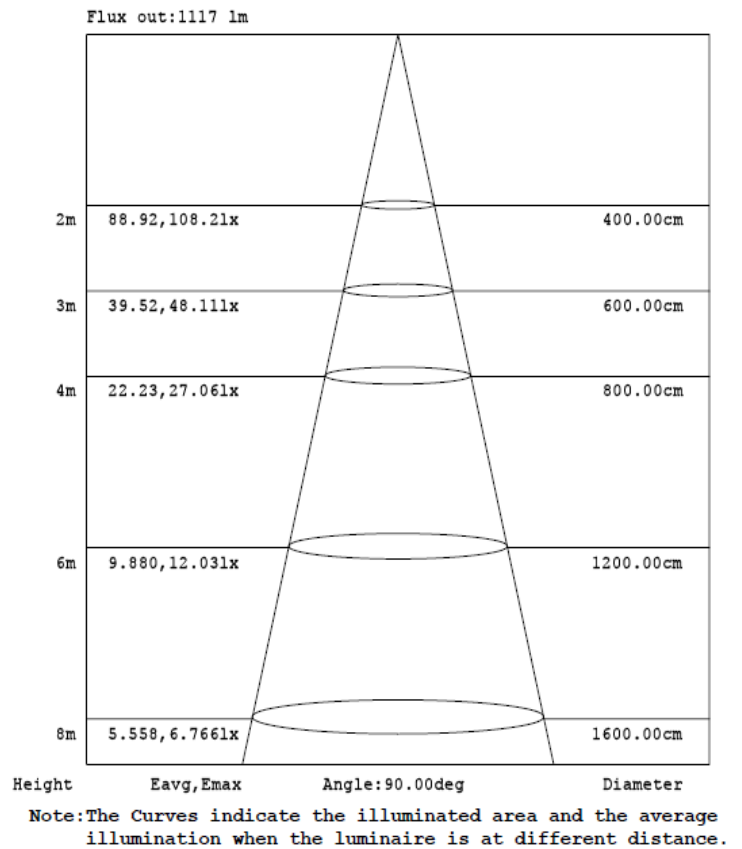
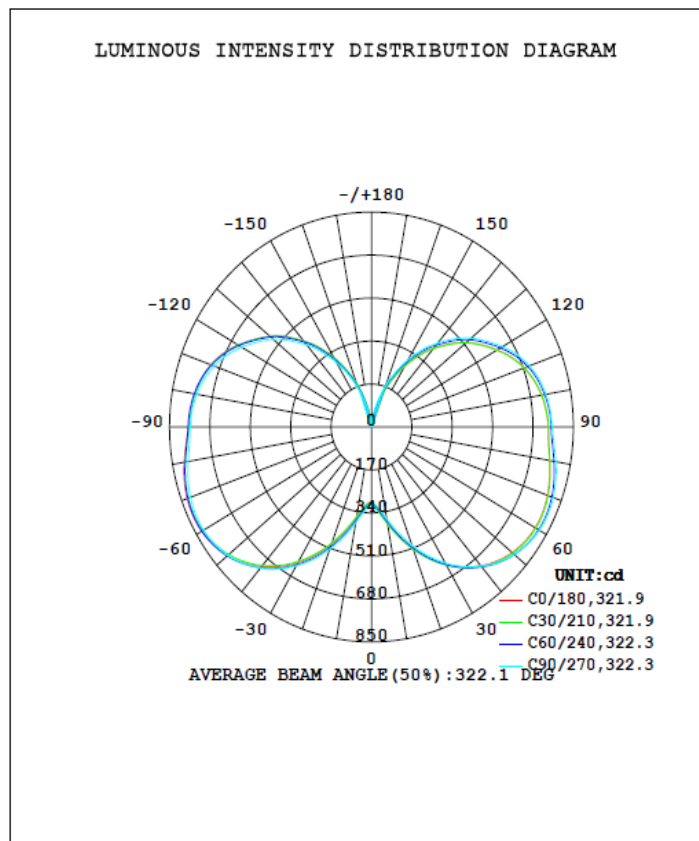

TECHNICAL DATA SHEET

Package

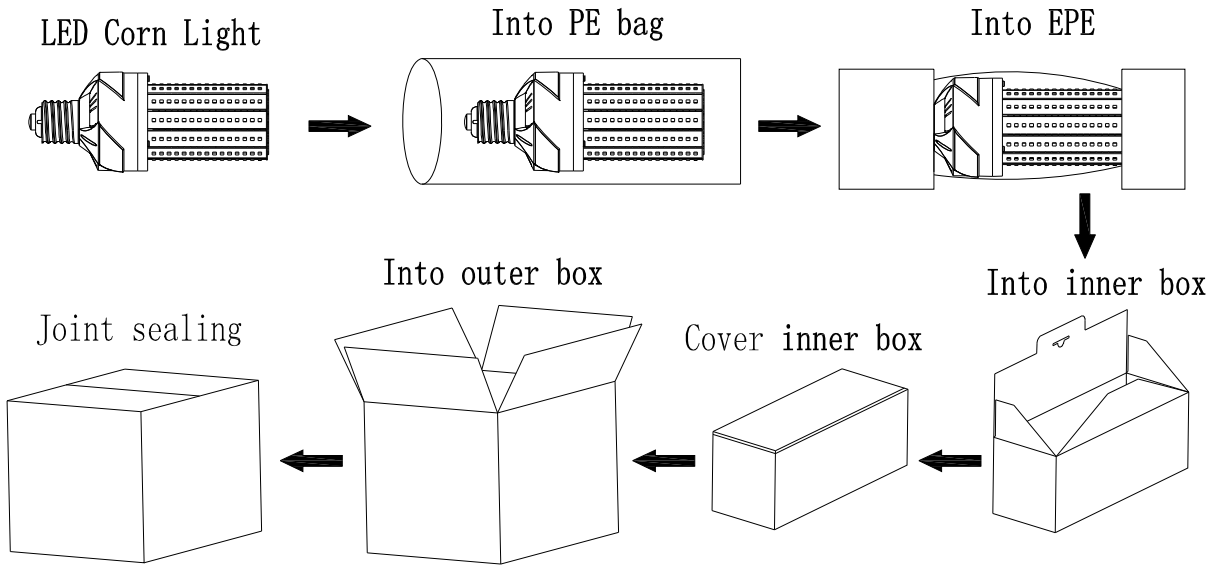

	Size (E26 and E39-S)	Size (E39-L)	Qty/ Carton	Net Weight/ Carton	Gross Weight/ Carton
Inner box	290*120*120 MM	310*120*120 MM	1 PC	0.44 KG	0.59 KG
Outer box	495*375*305 MM	495*375*325 MM	12 PCS	5.3 KG	8.2 KG

Notice For User

- Please turn off power before install or change assembly parts.
- The input voltage and lamps should be matched, after connecting the power line, please make sure the wiring section is insulated.
- Make sure to remove or bypass the ballast in the fixtures before install the lamps.
- Use in dry location only. Do not use with dimmers.
- Suitable for use in enclosed luminaires, min. lamp compartment dimensions: 320*190*190MM.
- No-professionals, must not install and disassemble the lamps.

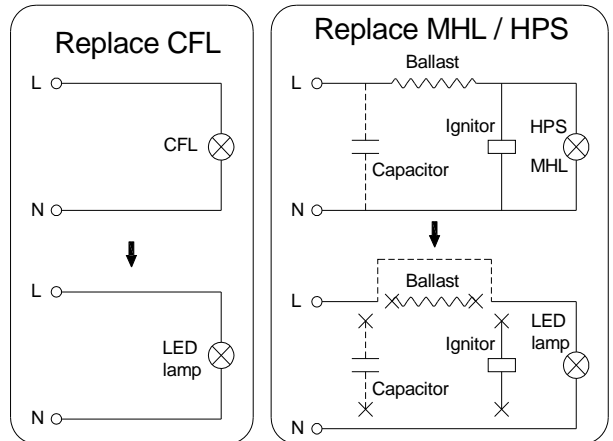

Trouble Shootings

Troubles	Check points
Flickering of the lamps	Turn off the power and turn on again in 3 minutes. If same phenomena occur, then call agencies
Out of working	Please check the connection