

TECHNICAL DATA SHEET

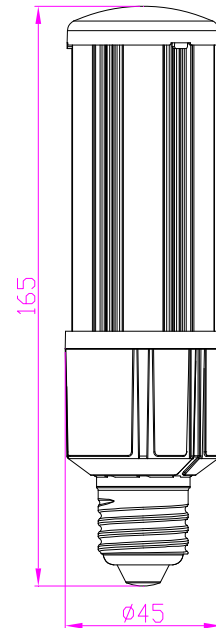

NAME: LED Corn Light

P/N: CLW-12WA1

Advantage

- UL、CUL certificate
- E26 lamp base
- Warm / Natural / Cool / Cold white
- 360 degree lighting, high CRI.
- IP64 Waterproof Rating
- Big heat sink
- Can be with clear or frosted cover.
- Internal driver, input voltage AC100-277V.
- New style and high efficient wide-range input.
- Long lifespan and good heat dissipation.
- Direct replacement for Metal Halide, Easy Installation.
- Fits many different fixtures to replace traditional lamps.



Application

Widely used in supermarket, warehouse, garage, home, office, hotel, hospital, school, street, garden etc.

TECHNICAL DATA SHEET

PRODUCT SPECIFICATIONS		
Product name	LED Corn Light	
Light Type	Corn Light	
Part No	CLW-12WA1	
Dimension	Φ45*165 MM	
Technical Characteristic		
Cover	Clear	Frosted
Color temperature	2700-6500K	
CRI	> 80	
Lumen	1440-1560 LM	1200-1320 LM
Lumen Efficacy	120-130 LM/W	100-110 LM/W
Input Power	12 W	
Viewing Angle	360 degree	
Input Voltage	AC100-277V 50/60Hz	
PFC	>0.9	
Equivalent	23W CFL , 35W MHL/HPS/HID	
Waterproof Rating	IP64	
MATERIALS		
LED Brand	EPISTAR	
LED Type	SMD2835	
LED QTY	98 PCS	
Housing	PC+AL	
Housing color	White+Grey	
OTHERS		
Operating Temperature	-20°C TO 45°C	
Operating Humidity	20%-70% RH	
Storage Temperature	-30°C TO 80°C	
Storage Humidity	10%-75% RH	
Application	Indoor/Outdoor	
Safety Certification	UL, CUL	
Warranty Time	5 Years	

TECHNICAL DATA SHEET

Remark: The testing data comes directly from the product test.

DATA OF LAMP		PHOTOMETRIC DATA Eff: 138.47 lm/W			
MODEL		I _{max} (cd)	187.8	S/MH (C0/180)	2.14
NOMINAL POWER (W)	12	LOR (%)	100.0	S/MH (C90/270)	2.43
RATED VOLTAGE (V)	120	TOTAL FLUX (lm)	1668.9	η UP, DN (C0-180)	20.0, 29.7
NOMINAL FLUX (lm)	1668.88	CIE CLASS	DIFFUSE	η UP, DN (C180-360)	20.9, 29.4
LAMPS INSIDE	1	η up (%)	40.9	CIBSE SHR NOM	2.00
TEST VOLTAGE (V)	120	η down (%)	59.1	CIBSE SHR MAX	0.00

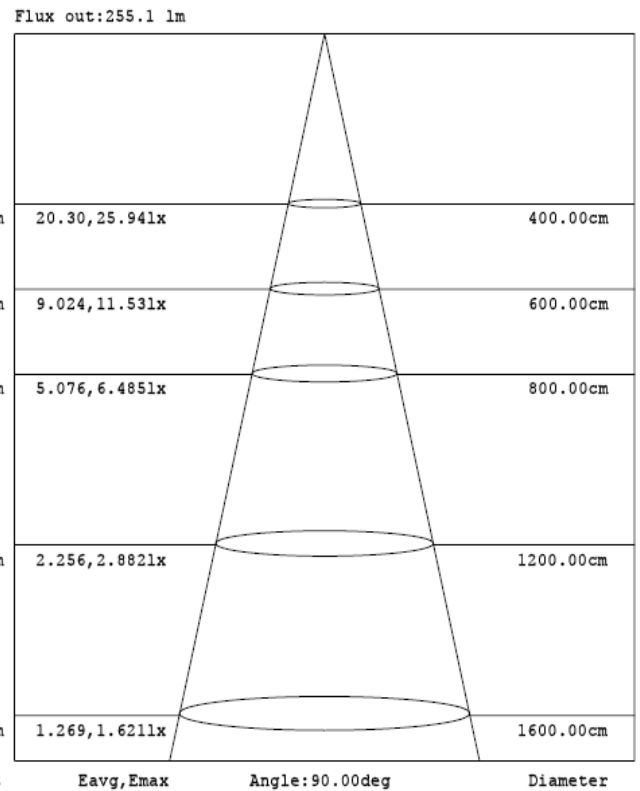
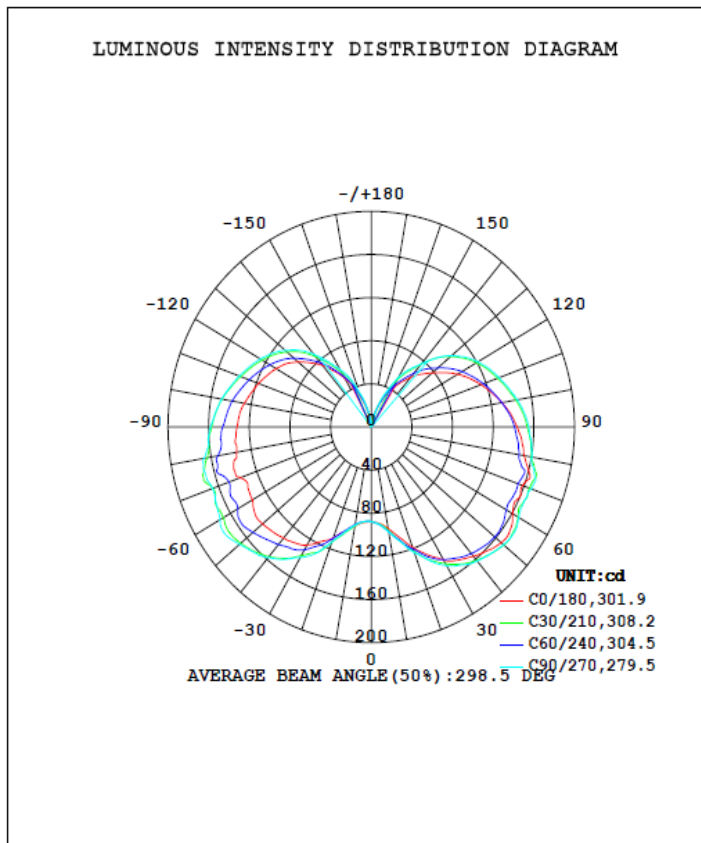

Note: The Curves indicate the illuminated area and the average illumination when the luminaire is at different distance.

TECHNICAL DATA SHEET

Package

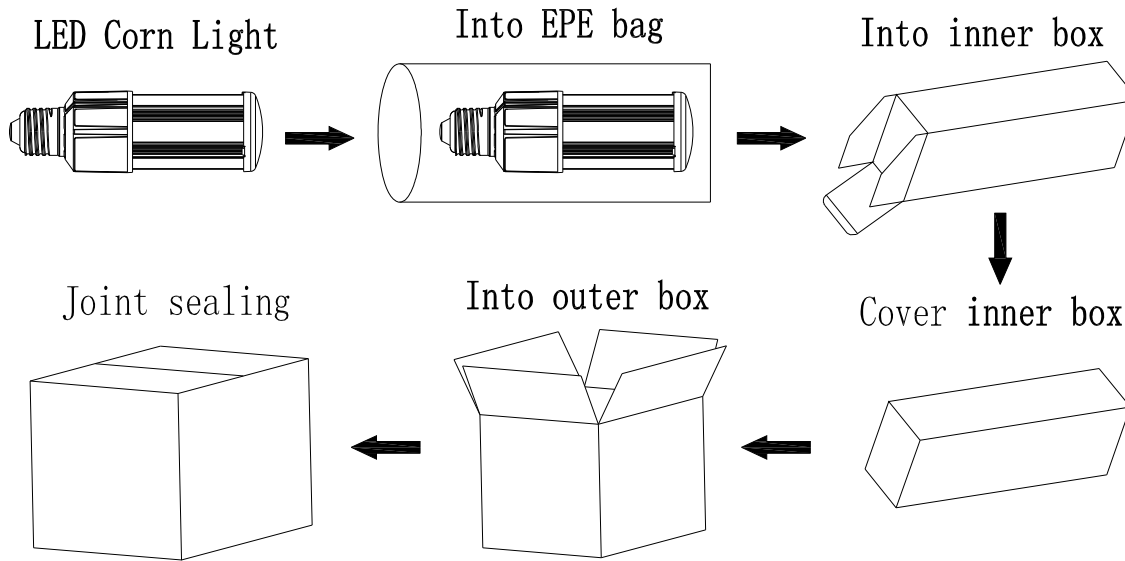

	Size	Qty/ Carton	Net Weight/ Carton	Gross Weight/ Carton
Inner box	165*45*45 MM	1 PC	0.14 KG	0.16 KG
Outer box	345*240*245 MM	50 PCS	7.0 KG	8.8 KG

Notice For User

- Please turn off power before install or change assembly parts.
- The input voltage and lamps should be matched, after connecting the power line, please make sure the wiring section is insulated.
- Make sure to remove or bypass the electronic ballast in the fixtures before install the lamps.
- Suitable for damp locations. Do not use with dimmers.
- Suitable for use in enclosed luminaires, min. lamp compartment dimensions: 300*190*190MM.
- No-professionals, must not install and disassemble the lamps.

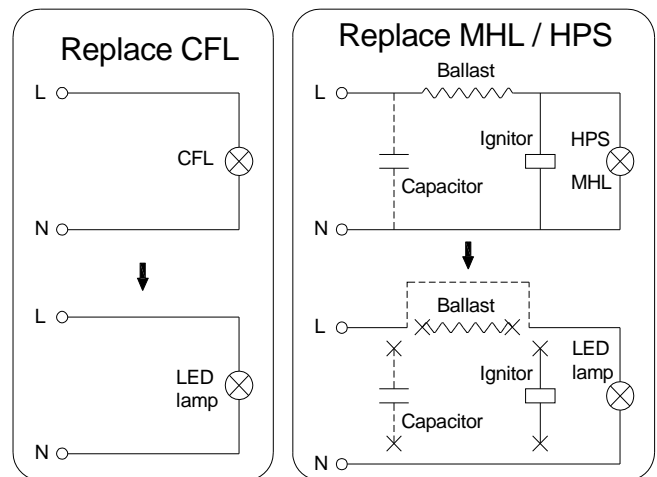

Trouble Shootings

Troubles	Check points
Flickering of the lamps	Turn off the power and turn on again in 3 minutes. If same phenomena occur, then call agencies
Out of working	Please check the connection