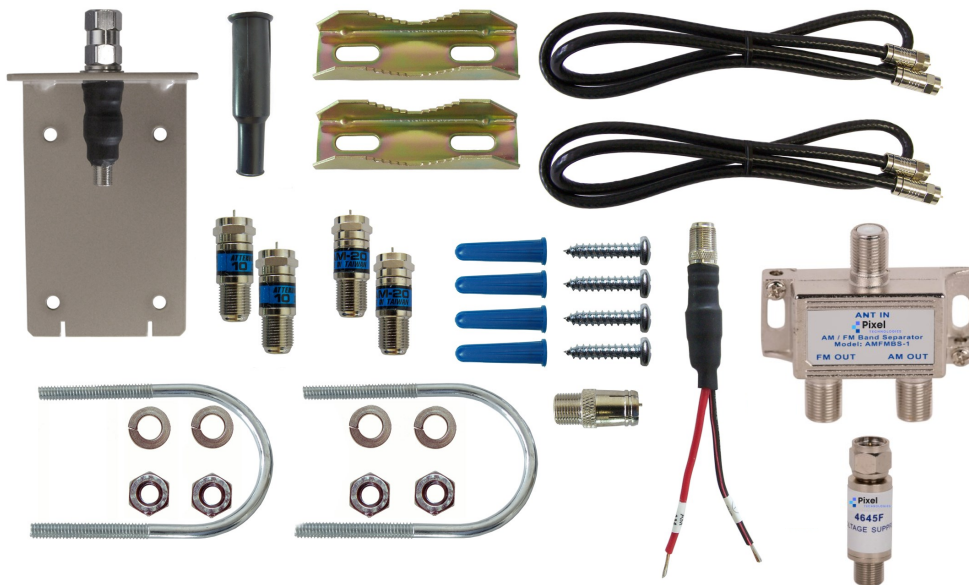

**SUPPLIED COMPONENTS:**

- (1) AM / FM antenna
- (1) L-mounting bracket
- (1) Weather boot
- (1) Surge protector
- (2) 20 dB attenuator
- (1) L-Mounting Bracket
- (1) AMIFM 48" Antenna Rod
- (2) 10 dB attenuator
- (2) 3 ft RG-6 cables
- (1) AMIFM band separator
- (2) U bolts with washers and nuts
- (2) Pole mount saddle brackets
- (4) Mounting screws with plastic inserts
- (1) F-female to twin-lead adaptor
- (1) Push-on F-female to DIN adapter

**Antenna Location (Very Important !)**

For optimum results the antenna should be mounted outdoors as high above ground and roof level and as far away as possible from any AM interference sources (see Table 1). It can also be mounted in an attic, but reception will depend on the roofing material and the insulation and siding materials. Thermal insulation that uses aluminum foil backing or metal roofing/siding material will shield the antenna from achieving good reception. Most stone and stucco siding has wire mesh reinforcement that will also block signal reception indoors. **Before finalizing the mounting location it is recommended to experiment with a few different temporary locations. AM and FM reception can vary greatly as function of the antenna's location.**

**Cable length, Type and Routing**

Always use good quality RG-6 cable and do not run the cable more than 200 ft. (The shorter the better for best FM reception). (RG-6 cable has a loss of about 2.8 dB / 100ft at the high end of the FM band (108 MHz)). For runs longer than 200 ft, a special wide-band line-amplifier (Model SBA-WB) is available to amplify the signal.

For AM reception, RG-6 cable loss is not an issue (only 0.33 dB per 100ft at 1.7 MHz) but for best rejection of local AM interference, Quad-shielded RG-6 should be considered. In addition, do not run the cable in parallel with cat 5 cables carrying digital signals or in parallel with AC power lines.

**Antenna Mounting**

The antenna L-bracket (Figure 1) should be first mounted in place to either a wall, chimney or a pole (not larger than 2 inches in diameter) with the supplied hardware as shown in Figures 2 and 3. The antenna should be as high above ground level as practical and as far away as possible from local AM interference sources and any structure (including aluminum siding) that could block reception. After mounting the L-bracket, screw the antenna rod into its base and tighten with a wrench.

Use the included weather boot with the lead-in RG-6 cable or other weather proofing means to seal the outdoor F-connector from moisture ingress.



Figure 1: L-Bracket

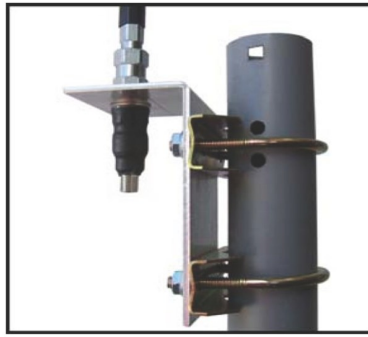
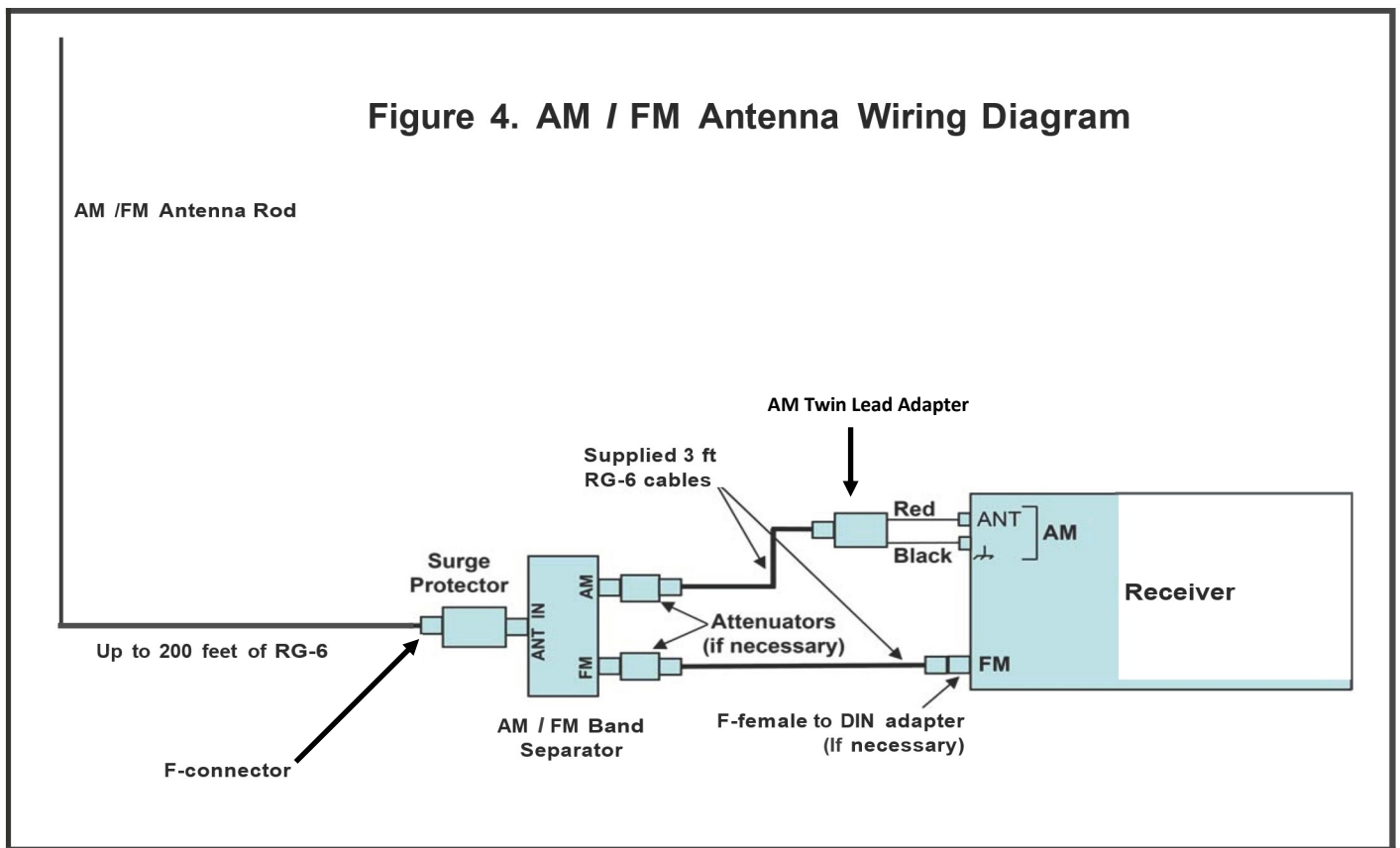

Figure 2: Pole Mount



Figure 3: Wall Mount

Wire the components as shown in Figure 4. **Make sure the surge protector is connected to the input of the AM / FM band separator and that the black wire from the coax- to- twin lead adaptor is connected to the ground input of receiver's AM antenna terminals.**



#### Attenuator Selection

Occasionally nearby high-power transmitters (TV, AM or FM) can overload your receiver's front-end causing cross-modulation distortion, audio distortion or noise. Use the supplied coaxial 10 dB (FAM-10) and 20 dB attenuators (FAM-20) on the outputs of the AM / FM band splitter to determine the best amount of attenuation that provides optimum reception.

To do this, first tune the radio manually across the entire AM band one step at a time (do not use the channel scan or search function of the receiver) and note the station frequencies that you are receiving well. Repeat this with first a 10 dB and then a 20 dB attenuator to determine if the attenuators help or hurt overall reception. The attenuators can be combined to achieve different amounts of attenuation. In most cases no attenuation is required and the best reception is achieved. Once the reception for the AM band is optimized, repeat these steps for the FM band to determine the best attenuator setting. These are standard cable-TV type attenuators that can be obtained from Pixel and many other sources if additional attenuation is required.

## AM Interference:

Unfortunately in this age of digital entertainment, AM radio has become the "weak sister" of features included in most entertainment systems. Most receiver manufacturers are spending the minimum possible amount on their AM tuning sections and the number of household source of AM radio interference has increased exponentially (see Table 1 below). Fortunately the emergence of Hybrid Digital (HD) AM radio technology is helping to cure some of these problems but the best strategy for good AM reception is to first eliminate as many of the interference sources as is practical and then locate the receiving antenna as far away as possible from the remaining interference sources. Using high quality well-shielded, Quad RG-6 lead-in wire from the antenna to the receiver will help reduce interference and optimize reception.

- Dimmer switch
- Neighbors dimmer switch
- Florescent light
- Computer
- Touch lamp (even when turned off)
- Automatic on/off night lights
- Automatic outdoor yard lights
- Electronic bug and pest controllers
- Light bulb that is about to burn out
- Faulty electrical switch
- Nearby television, plasma or LCD displays
- Neighbor using florescent lights
- Christmas tree lights & other blinking bulbs
- Neighbors dimmer switch (apt. complex)
- Cell phone chargers
- Dirty insulators on nearby power pole
- Electric blanket
- 120V AC smoke detectors (battery operated OK)
- Ionic Breese or other electrostatic air purifier
- Ultrasonic motion detectors
- Appliances with motors
- Lap top computer power supply
- Almost any wall mounted power supply that uses a "switching design"
- Computer network "Cat 5 or Cat 6" wiring

## Specifications:

**Antenna length:** 48 inches

### Frequency of operation:

AM Band 500 KHz to 1750 KHz

FM Band 88MHz -108 MHz

**Ground plane required:** None

**AM capture length:** 300 inches

### AM | FM Band Separator Performance:

FM rejection in AM band: > 50 dB

AM rejection in FM band: > 60 dB

AM/FM Pass-band loss: < 1dB

AM load impedance: 300 ohms

FM load impedance: 75 ohms

**Antenna Beam width:** Omni-directional



**Reception Performance:**

These results will vary as function of the antenna's height above ground, the power of the transmitting station, the transmitter's antenna beam pattern, the local terrain and the quality of the receiver utilized. Table 2 shows actual reception test results for the antenna mounted 20 feet above ground over flat terrain, using a Sangean Model HDT-1X as the receiver with 200 ft of cable between the antenna and receiver.

**IMPORTANT ! - THE ANTENNA BRACKET ASSEMBLY COMES TIGHTENED TO THE PROPER TENSION. DO NOT TIGHTEN THE NUT ASSEMBLY OR REMOVE THE NUT ASSEMBLY FROM THE L-BRACKET. TIGHTENING OR REMOVING THE NUT ASSEMBLY ON THE L-BRACKET MAY CAUSE THE ANTENNA TO NOT FUNCTION PROPERLY.**

**Table 2. Reception Capability**

Receiver Mode	Reliable Good Quality Daytime Reception
FM Stereo	80 Miles
FM HD	50 Miles
AM (Mono)	90 Mile
AM HD	50 Mile

Receiver	Sangean HDT-1X
Cable Length (antenna to receiver):	200 feet RG-6 cable
Antenna height above ground:	20 feet
Terrain:	Flat