

SHERLE WAGNER INTERNATIONAL

STRAINER WASTE ASSEMBLY WSTE-STNR-XX

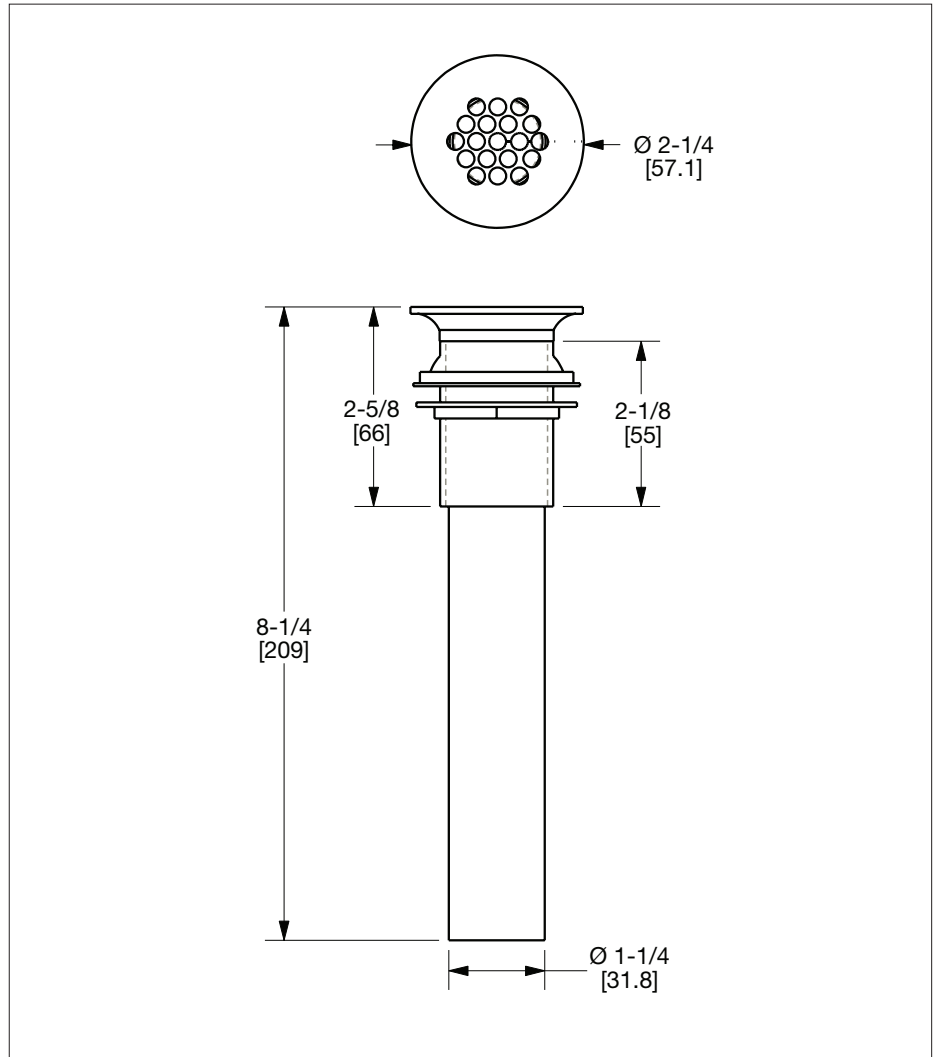
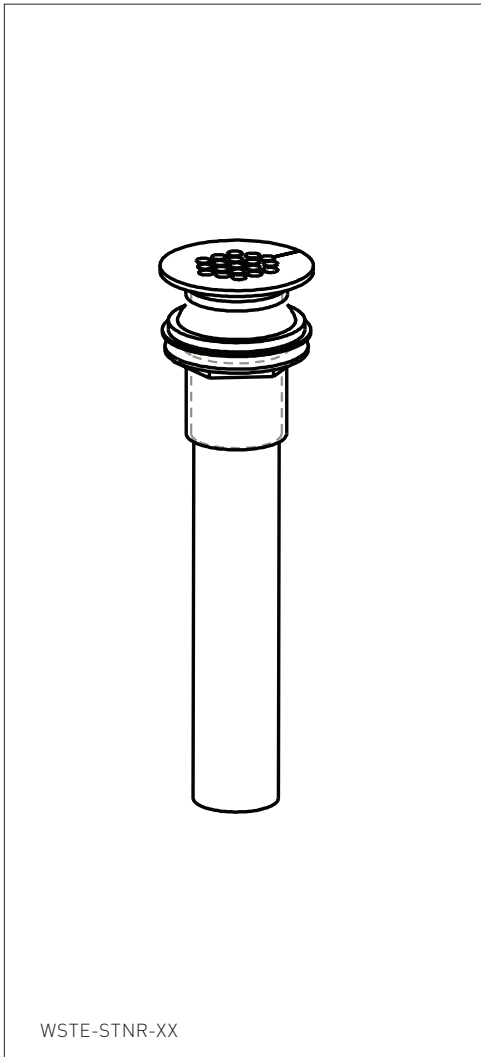

PRODUCT FEATURES

- o Available in all Sherle Wagner International finishes
- o Solid brass/bronze construction
- o Mounting hardware included

AVAILABLE METAL FINISHES

PN Polished Nickel
CP Polished Chrome
BN Brushed Nickel
BC Brushed Chrome
SB Satin Brass

OB Oil Rubbed Brass
PB Polished Brass
GP Gold Plate
AL Almond Gold
RG Rose Gold

ES English Silver
BS Butler Silver
AP Antique Pewter
PE Black Pearl
BG Burnished Gold

AG Antique Gold
SP Satin Platinum
HP High Polished Platinum
BP Burnished Platinum