

# SHERLE WAGNER INTERNATIONAL

## KEYSTONE DOUBLE POST PAPER HOLDER 2060PH-DP-XX



### PRODUCT FEATURES

- o Available in all Sherle Wagner International finishes
- o Solid brass/bronze construction
- o Includes mounting hardware

### AVAILABLE METAL FINISHES

**PN** Polished Nickel  
**CP** Polished Chrome  
**BN** Brushed Nickel  
**BC** Brushed Chrome  
**SB** Satin Brass

**OB** Oil Rubbed Brass  
**PB** Polished Brass  
**GP** Gold Plate  
**AL** Almond Gold  
**RG** Rose Gold

**ES** English Silver  
**BS** Butler Silver  
**AP** Antique Pewter  
**PE** Black Pearl  
**BG** Burnished Gold

**AG** Antique Gold  
**SP** Satin Platinum  
**HP** High Polished Platinum  
**BP** Burnished Platinum

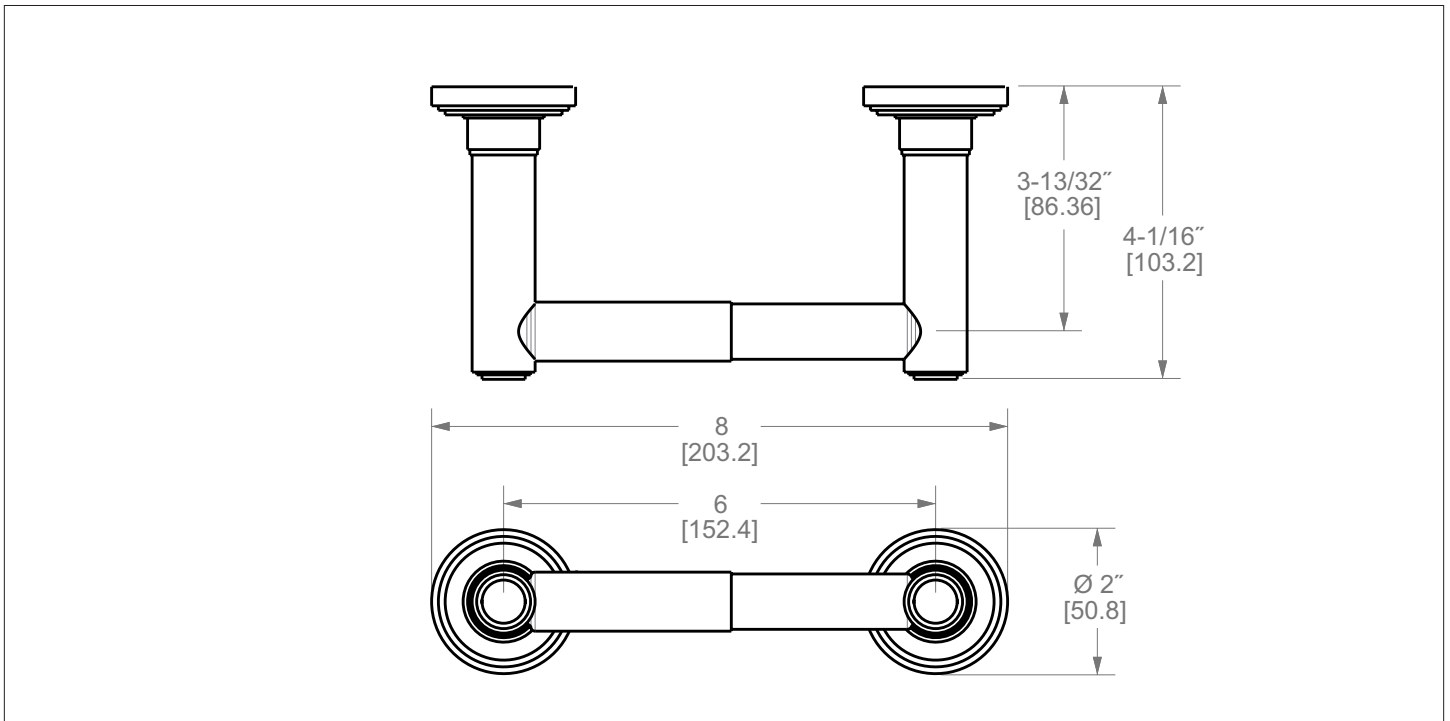

The measurements shown are for reference only. Products and specifications shown are subject to change without notice.

Rev A