

SHERLE WAGNER INTERNATIONAL

CHISELED ROUND CERAMIC VESSEL 15RD-VSL-CHIS-XXXX



PRODUCT FEATURES

- o Vitreous China
- o 1-3/4" trap diameter
- o Counter basin
- o 3.8" water depth
- o Contact sales associate for custom glaze options

AVAILABLE CERAMIC GLAZE COLOR

WHT White Glaze	SND Sand Glaze	BLK Black Glaze	CUST Custom Glaze
15PL Burnished Platinum	14GP Burnished Gold	17HP Highly polished Platinum	

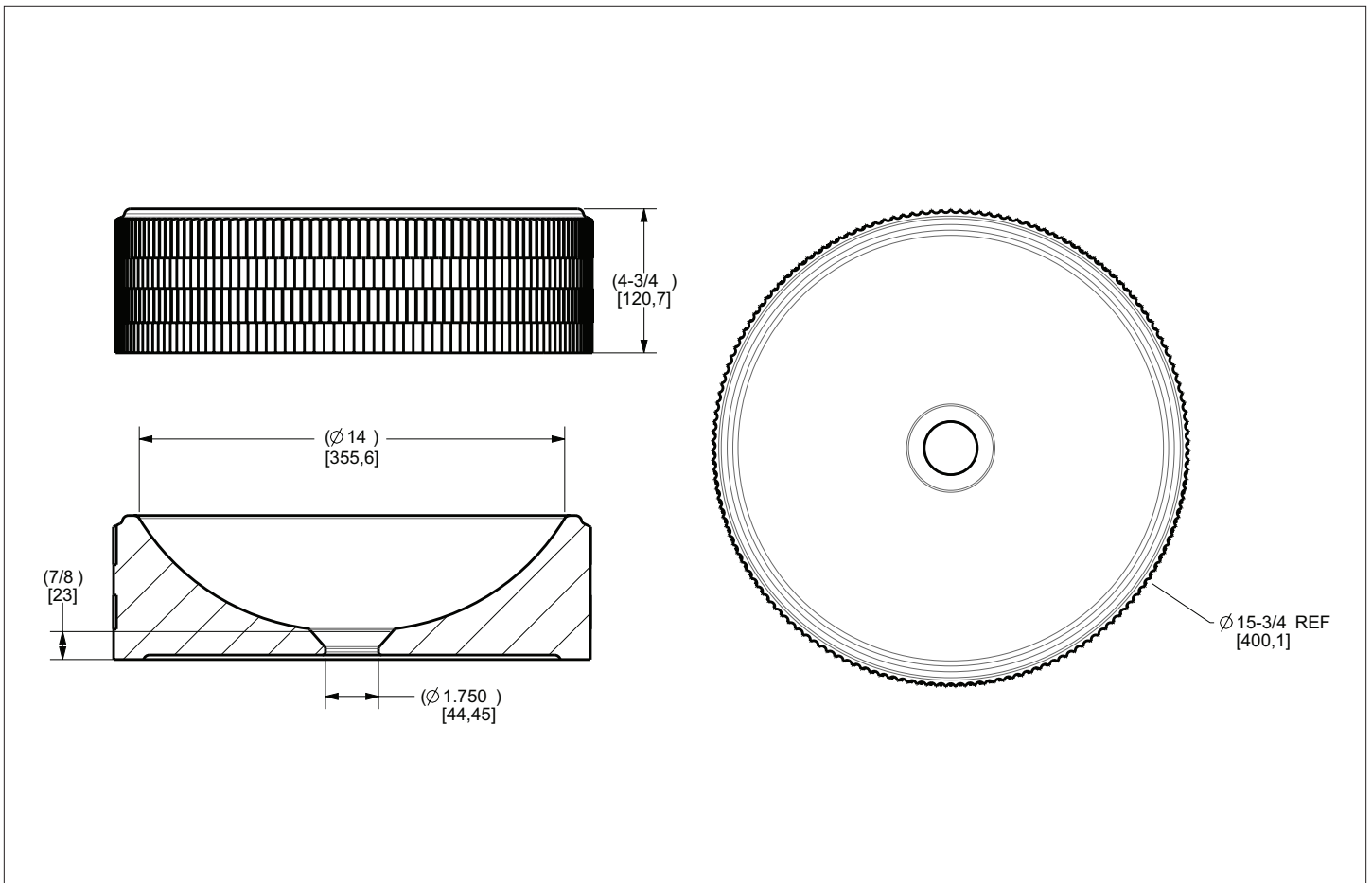

The measurements shown are for reference only. Products and specifications shown are subject to change without notice.

Rev A