

## B1515-3 300mm

### Notes:

- Benchtop basin
- Polymarble or solid surface composition
- 10 years manufacturers warranty

### Finishes:

- Matte white
- Gloss white
- Full colour range

### Options:

- Stone waste (matte white)

**Size:** 300 x 300 x 110 (mm)



300

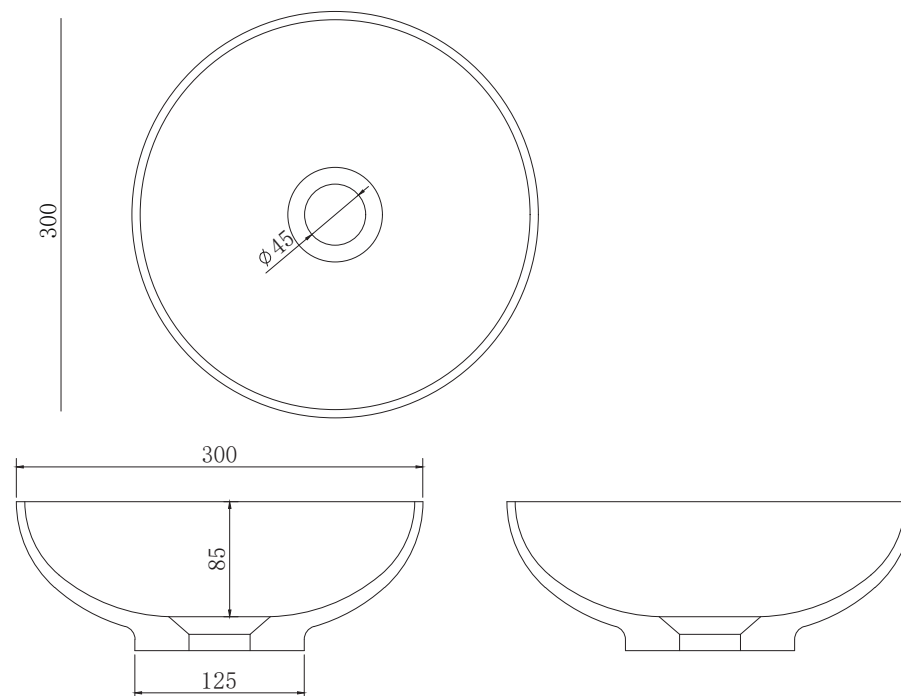

Net weight: 3.5kg  
Gross weight: 5kg  
Unit: mm