

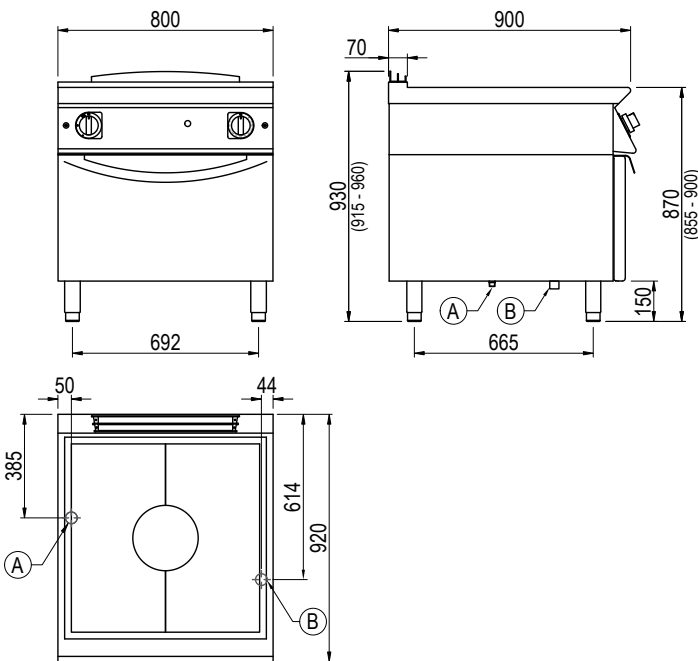

Product Information:

- Class leading, European style, professional quality and reliability since 1963
- 900 series, ultra-thick, reinforced radiant plate with central cut-out and high-power circular steel burner (56 MJ/h) and standard gas 2/1GN oven (28.8 MJ/h)
- Solid top with piezo ignition circular burner, flame failure device and pilot burner capable of reaching 500°C at the centre of the plate and 200°C around the edges
- Solid top temperature regulation via variable power flame control
- Piezo ignition gas oven with thermostat temperature control (100°C – 300°C)
- Robust 304 grade stainless steel construction with rounded corners for improved cleaning
- Height adjustable stainless steel feet for a 900mm working height
- 24-month warranty

General Drawing:



Specifications:

Model	TG940FT	
W x D x H (mm)	800 x 920 x 930	
Weight	190kg	
Plate Dimensions (mm)	700 x 500	
Oven Cavity (mm)	693 x 580 x 300	
Packed Dimensions (mm)	845 x 1025 x 1200	
Packed Weight (mm)	195kg	
Gas Connection	Natural 1/2" BSP	Universal LPG 1/2" BSP
Minimum Normal Test Gas Pressure	1.3 kPa	2.75 kPa
Maximum Normal Test Gas Pressure	3.5 kPa	3.5 kPa
Nominal Test Point Pressure	1.0 kPa	2.65 kPa
Total Nominal Gas Consumption	84.8 MJ/h	84.8 MJ/h

Note: It is the responsibility of the installing gas plumber to ensure correct supply and connection sustaining appropriate pressure, when all installed gas appliances are operating at maximum.

Legend:

- A** Gas Connection
- B** Drain Connection