

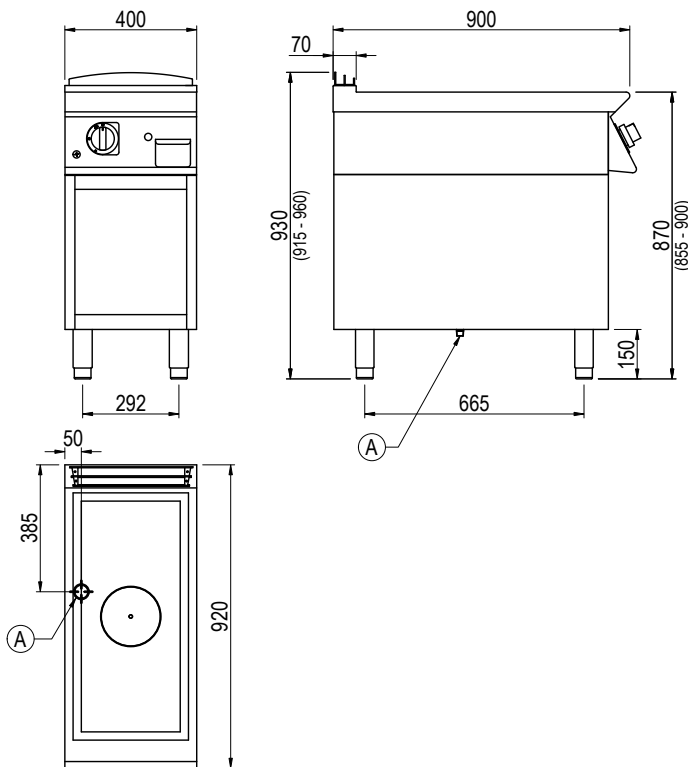

Product Information:

- Class leading, European style, professional quality and reliability since 1963
- 900 series, ultra-thick, reinforced radiant plate with central cut-out and high-power circular steel burner (28 MJ/h)
- Piezo ignition circular burner with flame failure device and pilot burner capable of reaching 500°C at the centre of the plate and 200°C around the edges
- Temperature regulation via variable power flame control
- Robust 304 grade stainless steel construction with rounded corners for improved cleaning
- Removable grease tray
- Open base with optional door available (SPGI.2016437)
- Height adjustable stainless steel feet for a 900mm working height
- 24-month warranty

General Drawing:



Specifications:

Model	TG920GT	
W x D x H (mm)	400 x 920 x 930	
Weight	82kg	
Plate Dimensions (mm)	300 x 700	
Packed Dimensions (mm)	450 x 1025 x 1200	
Packed Weight (mm)	89kg	
Gas Connection	Natural 1/2" BSP	Universal LPG 1/2" BSP
Minimum Normal Test Gas Pressure	1.3 kPa	2.75 kPa
Maximum Normal Test Gas Pressure	3.5 kPa	3.5 kPa
Nominal Test Point Pressure	1.0 kPa	2.65 kPa
Total Nominal Gas Consumption	28 MJ/h	28 MJ/h

Note: It is the responsibility of the installing gas plumber to ensure correct supply and connection sustaining appropriate pressure, when all installed gas appliances are operating at maximum.

Legend:

A Gas Connection