



# HOSHIZAKI

# KM-140C-HC

## Crescent Ice Maker - Self-Contained



NATURAL REFRIGERANT

Model Number: 91000910

## PRODUCT FEATURES

- Individually shaped crescent ice.
- Protected by HoshiGuard Antimicrobial Agent.
- CycleSaver® technology includes a double-sided evaporator, uniquely crafted in stainless steel, which produces ice on both sides, resulting in more ice in less amount of time.
- EverCheck™ Control Board with audible alarm and diagnostic features, designed to assist service technicians in diagnosing problems.
- Accessible digital operation panel allows for easy identification of operation status and cause of faults.
- Automated Cleaning function makes cleaning simple and saves time.
- Durable stainless steel exterior.
- Easily removable & cleanable air filters on front panel.
- Accessories : Manual, Scoop, check valve and 150mm adjustable legs included (water filter sold separately)



## PRODUCT SPECIFICATION

Production Capacity / 24hrs	Approx. 130kg @ 21°C Air temp; 15°C Water Approx. 115kg @32°C Air temp; 21°C Water
Bin Storage Capacity	Approx. 55kg (Bin Control Setting Approx. 47kg)
Freeze Cycle Time	Approx. 21 Min (At. 21°C Air ; 15°C Water)
Ice Production / cycle	Approx. 1.87kg/208pcs
Dimensions	630mm (W) x 719mm (D) x 1194mm (H) (1333-1356mm [H] with 150mm adjustable legs)

Cooling	Air
Weight Net/Gross (kg)	69/81
AC Supply Voltage	1 PHASE 220-240V 50Hz / 10amp Plug
Amperage	Running: 3.9A
Refrigerant Charge	R290/110g
Operating Conditions:	
Ambient Temp.	7-38°C
Water Supply Temp.	7-32°C
Water Supply Pressure	0.07-0.8MPa (0.7- 8bar)
Voltage Range	±6%
Electrical consumption	11.1kWh per 100kg ice (AT. 32°C; WT 21°C)
Water Consumption / 24hrs	Approx. 0.17m3/d (AT. 32°C ; WT 21°C)
Compatible Water Filter	HLF20 Filter System (sold separately)

## TECHNICAL DRAWING

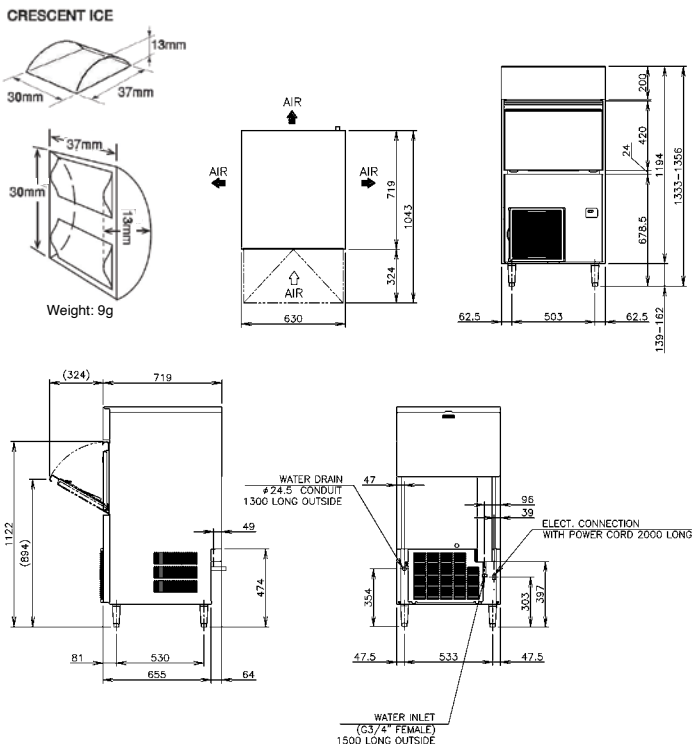

For free 6 month extended warranty, register online within 4 weeks of purchase date.

[hoshizaki.com.au](http://hoshizaki.com.au)

## INSTALLATION REQUIREMENTS

- Qualified plumber required for installation.
- Allow 15cm clearance at rear, sides and top for proper air circulation and ease of maintenance.
- Hoshizaki recommends the use of a compatible water filter to prevent non-warrantable scale & sediment complications.

\*Refer to manual for full installation & maintenance requirements.

