

# TOASTMAX

CONVEYOR TOASTER



Model TM-10H

## All the features of a high-end toaster... with a low-end price

The Hatco Toast-Max economy conveyor toaster offers the flexibility and performance to perfectly toast bread and buns fast – up to 300 slices per hour! Utilizing conveyor speed, not temperature, to determine toasting color, allows for instant adjustment of toasting time.

- 4-position toast selector switch: off / toast / buns / stand-by mode
- 89 mm (3 1/2") clearance to accommodate high profile bread products
- Easy-to-load rack with front or rear discharging
- Permanently lubricated 50/60 Hz motor
- V-shaped reflectors help capture and redirect heat

- Long lasting serpentine metal sheathed heating elements
- 102 mm (4") adjustable legs
- Pilot light that signals unit is in operation
- Discharge and crumb trays are removable for easy cleaning





# TOAST-MAX™ CONVEYOR TOASTERS

Model TM-10H

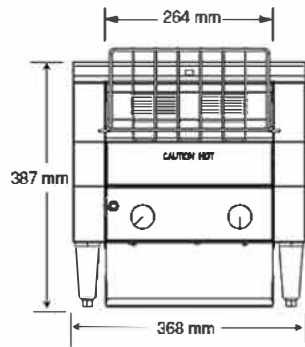

FRONT VIEW

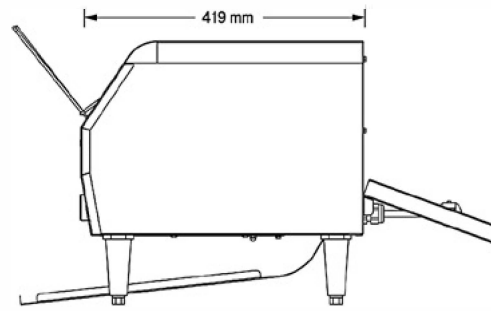

SIDE VIEW

Models TM-10H

## SPECIFICATIONS

Model	kW	Type	Cap./Min.†	Shipping Weight
TM-10H	1.9	Bread & Buns	6 slices	19 kg(41 lbs.)

† Toasting capacity may vary by product. Toasting of coated products is not recommended.

## DIMENSIONS

TM-10H: 368 W x 419 D x 387 H mm

### Interior Cavity Openings:

TM-10H: 264 W x 88 mm H

### Maximum Product Size:

245 W x 64 mm H

### CORD LOCATION

Left side of back of unit near center. Supplied with 10A plug

## SELECTOR CHART

(Based on serving 2 slices per customer.)

Number of Customers	Serving Time TM-10H
30	12 minutes
60	24 minutes
90	36 minutes
120	48 minutes

## ELECTRIC RATING

Model	Volts	Watts	Amps	Hz
TM-10H	220-240	1940-2300	8.8-9.6	50-60

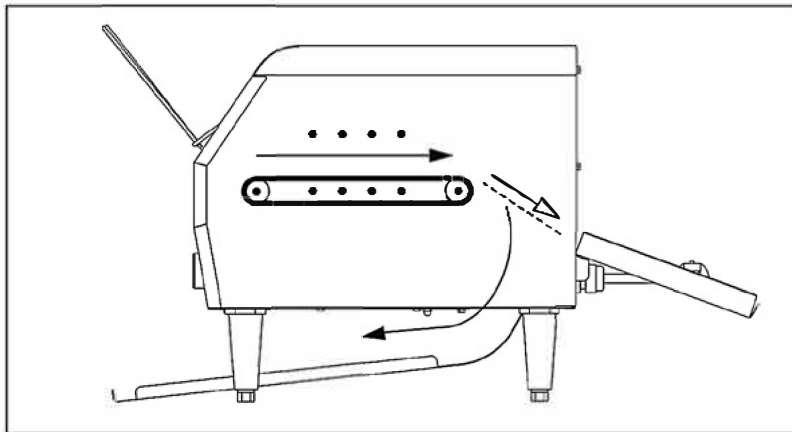

Product Flow