

FCC STATEMENT

NOTE: This equipment has been tested and found to comply with the limits for a Class B digital device, pursuant to Part 15 of the FCC Rules. These limits are designed to provide reasonable protection against harmful interference in a residential installation. This equipment generates, uses and can radiate radio frequency energy and, if not installed and used in accordance with the instructions, may cause harmful interference to radio communications. However, there is no guarantee that interference will not occur in a particular installation. If this equipment does cause harmful interference to radio or television reception, which can be determined by turning the equipment off and on, the user is encouraged to try to correct the interference by one or more of the following measures:

- Reorient or relocate the receiving antenna.
- Increase the separation between the equipment and receiver.
- Connect the equipment into an outlet on a circuit different from that to which the receiver is connected.
- Consult the dealer or an experienced radio / TV technician for help.

This device complies with Part 15 of the FCC Rules. Operation is subject to the following two conditions:

(1) this device may not cause harmful interference, and (2) this device must accept any interference received, including interference that may cause undesired operation.

WARNING: Changes or modifications to this unit is not expressly approved by the party responsible for compliance could void the user's authority to operate the equipment.

COMFIER
Massage Chair

Know more about Comfier



COMFIER TECHNOLOGY CO.,LTD

Address: 573 BELLEVUE RD NEWARK, DE 19713 USA

Tel: (248) 819-2623 (Monday-Friday 9:00AM-4:30PM)

Facebook: www.facebook.com/comfiermassager

Email: supportus@comfier.com

Web: www.comfier.com

*Please provide your order number before contacting customer support



User Manual
CF-9212

▶ COMFIER MASSAGE CHAIR

Thank you for purchasing the **COMFIER** Massage Chair. Before using this chair for the first time, please read through all sections of this User Manual carefully, paying special attention to the Safety Instructions.

PLEASE RETAIN THIS MANUAL FOR FUTURE REFERENCE.

▶ CONTENTS

IMPORTANT SAFETY PRECAUTIONS.....	1
PARTS.....	3
Exterior Structure.....	3
Interior Structure.....	3
Power Supply.....	4
Main Controller.....	5
MESSAGE CHAIR OPERATION.....	6
Controller Operation.....	6
SETUP.....	8
Installation.....	8
Bluetooth Setup.....	10
Moving the Chair.....	11
Massage Chair Placement.....	12
Before Using the Chair the First Time.....	13
Grounding Instructions.....	14
PRODUCT STORAGE AND MAINTENANCE.....	15
TROUBLESHOOTING & TECHNICAL SPECIFICATIONS.....	16
WARRANTY.....	17

▶ IMPORTANT SAFETY PRECAUTIONS

Please pay close attention to the following safety information while using your massage chair. Please carefully read all instructions before using this product.

WARNING

In order to reduce risk of fire, burns, electric shock or injury to others, please abide by the following instructions:

1. Be sure to unplug the unit when it is unattended. Ensure that it is left unplugged when not in use or before installing or removing any parts.
2. Children and any person requiring special care should use this unit under adult supervision.
3. Be sure to use this unit for the purposes described in this manual. Please do not install parts and accessories not provided by the manufacturer.
4. This unit must not be used under these conditions:
 - a) the power cord or plug is damaged;
 - b) the unit is malfunctioning or operating incorrectly;
 - c) the unit is damaged or exposed to water.Contact our service center for inspection and repair.
5. Do not move this massage chair by pulling the power cord or using the cord as a handle.
6. Be sure to keep the power cord away from any source of heat.
7. Do not use this unit when the air outlet is blocked. Please keep the air outlet unblocked and free from hair and dust.
8. Do not drop or insert any objects into any opening.
9. Do not use this product outdoors.
10. Do not use this product in areas where aerosol products are used or oxygen is being released.
11. To power off, please switch off all controls before unplugging.
12. Please do not stand on or in the unit. It can only be used in a seated position.
13. Be sure to supervise children and ensure that they do not use the unit as a toy or for playing.
14. Connect this unit to a properly grounded outlet only. See Grounding Instructions (Page 14).
15. This unit is not intended for use by persons (including children) with reduced sensory or mental capabilities, or those with a lack of experience or knowledge of its operation, unless they have been given supervision or instruction concerning use of the appliance by a person responsible for their safety. Children should be supervised to ensure that they do not play with the unit.
16. If the covering is torn or worn away, do not use the unit and return to service center for replacement of outer cover.

SAVE THESE INSTRUCTIONS

This massage chair is intended for household use only. Please consult a doctor before using the massage chair if it is to be used by a child or persons with any medical condition.

▶ IMPORTANT SAFETY PRECAUTIONS

⚠ CAUTION

Anyone with the following conditions should consult a medical professional before using this device:

- Persons using embedded medical electronic devices such as a pacemaker.
- Women who are pregnant or who have just given birth.
- Persons with sensory loss or numbness.
- Persons with sensitivity to heat.
- Persons with bodily injuries including open wounds on the skin.
- Persons with bone injuries or with weak bones, loss of bone density, or who are otherwise prone to damaging or bruising bones.
- Persons using blood thinners or who bruise easily.
- Persons with skin disorders or who are prone to allergic reactions of the skin (sensitive skin).
- Any illness or injury that may cause you to be adversely affected by heat or massage pressure.

General Safety Precautions:

- Do not use unit if it shows signs of malfunctioning or damage. Do not use if there are any rips or tears in the fabric that may expose the moving parts underneath, as serious injury can result.
- Setup unit properly by following all instructions in the section "Setup." Failure to follow proper setup and use instructions can cause injury or damage.
- Do not use the unit for longer than 30 minutes at one time. Continual use to one specific part of the body should not exceed five minutes. Excessive massage or heat applied to one area can cause injury or discomfort.
- Do not use the heat function for long periods of time, as low-temperature burns may occur.
- If rashes, skin reddening, itching, or other skin discomfort or skin reactions occur, discontinue use and consult a medical professional.
- Do not leave unit unattended while plugged in. Keep chair powered off and unplugged when not in use or when not supervised.
- Do not sleep in the unit while it is in use.
- For use by only one person at a time.
- Do not use accessories while using the unit, including added heat blankets or pads or other heating units, and including any other massage units or electronic devices.
- Wear loose, comfortable clothing when using the chair.
- Remove items that can cause injury during a massage, including: jewelry, hair accessories and hats, belts, glasses, and any other hard items that could be pressed against your skin. Empty all items from pockets, including wallets.
- Do not unplug or flip the power switch when the unit is in use.
- Do not move the unit while it is in use or while anyone is in it.
- Not intended for use by pets, elderly persons, children, disabled persons, drowsy/inebriated persons, or persons with sensory loss.

Have question ?

☎ Tel: (248) 819-2623
Monday-Friday 9:00AM-4:30PM

✉ Email: supportus@comfier.com

▶ PARTS

EXTERIOR STRUCTURE

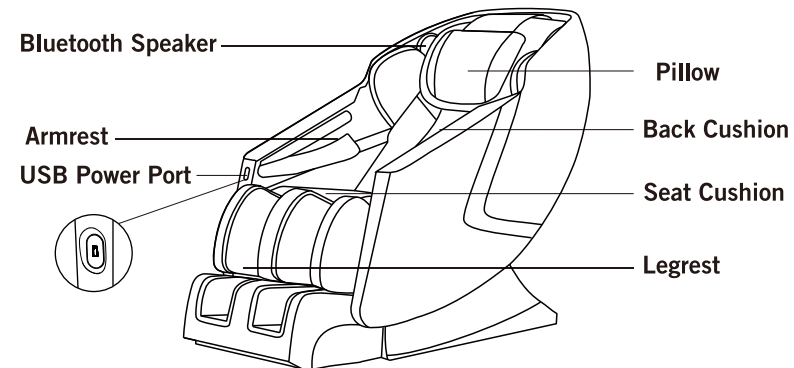

INTERIOR STRUCTURE

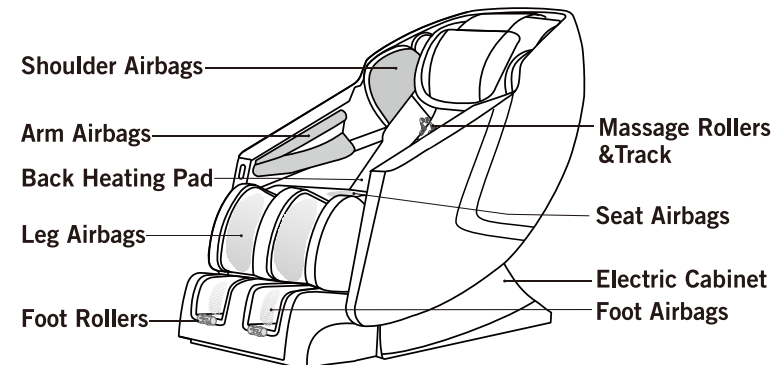

POWER SUPPLY

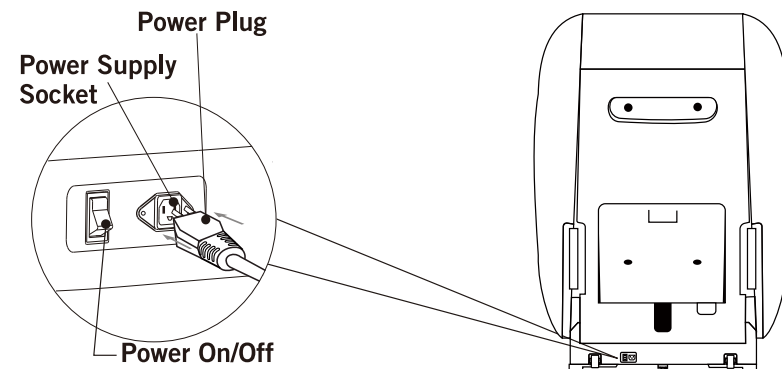

▶ PARTS

MAIN CONTROLLER

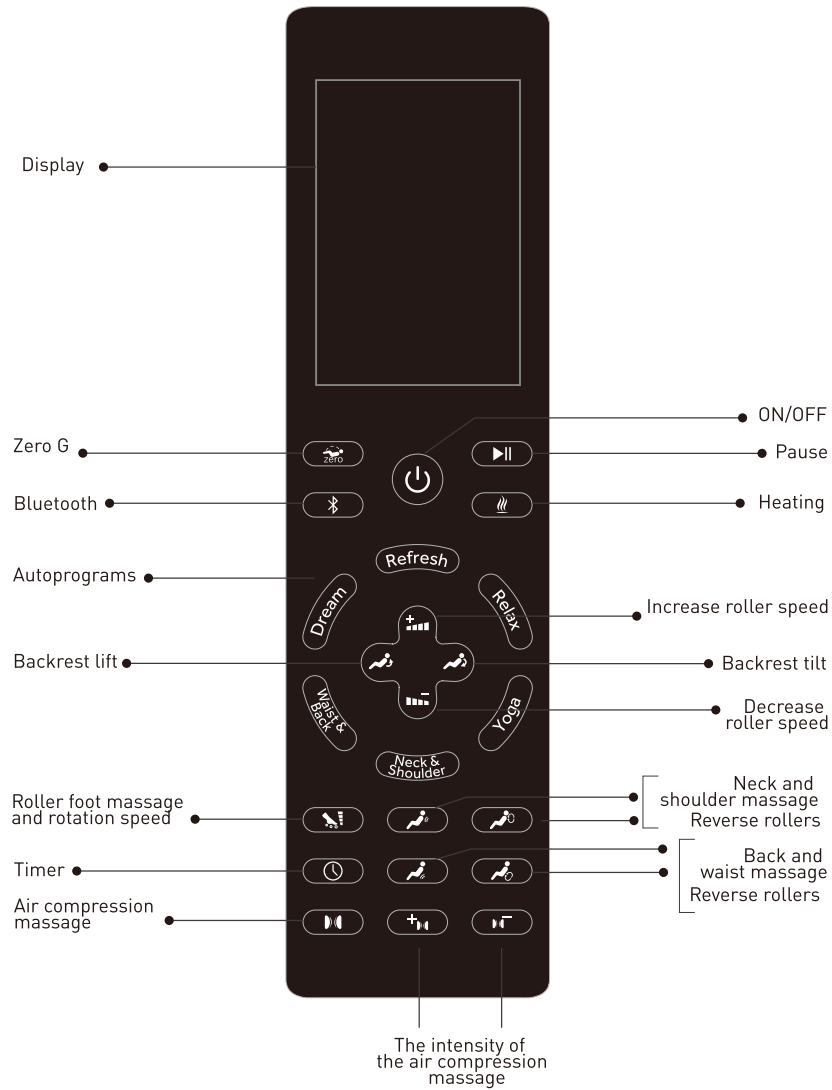

▶ MESSAGE CHAIR OPERATION





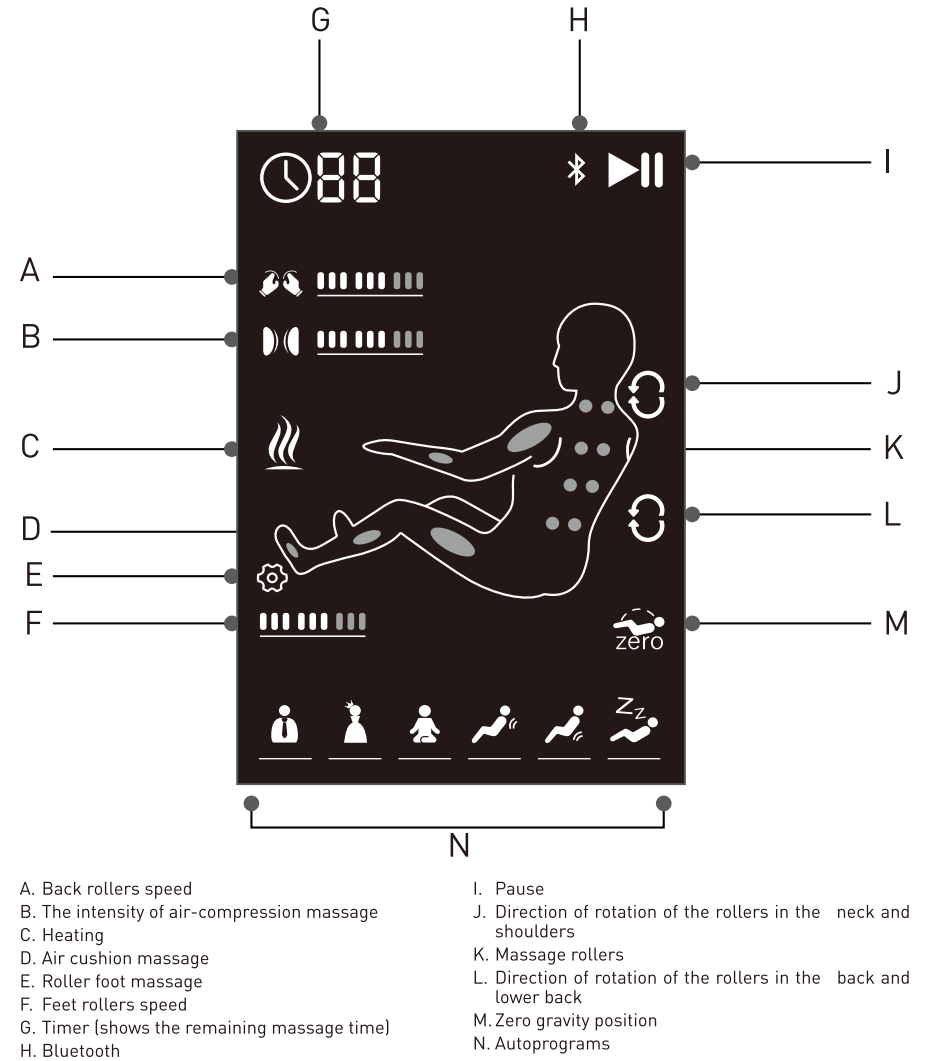













DESCRIPTION OF THE GRAPHIC IMAGES ON THE CONTROL PANEL

The indicators on the screen show what effect is taking place at the moment.



▶ MESSAGE CHAIR OPERATION

CONTROLLER OPERATION

ON/OFF		When the power is on, press this button to turn the massage chair on or off.
Zero G or zero gravity		Press this button to turn the "zero gravity" function on or off. The same button can be used to select the tilt position in zero gravity mode.
Pause		Press this button to pause all massage functions of the chair, then press it again to resume massage.
Bluetooth		Press this button to turn the Bluetooth function on/off. Bluetooth connection From your cell phone's list of Bluetooth devices, select this chair for connection, when you hear the sound, the connection will be established.
Heating		Press this button once to turn on the heating function, the icon # will appear on the screen. Press it again to turn off the heating function, the icon will turn off.
Autoprograms		Press any of these buttons to select one of 6 automatic massage programs: refresh, relax, yoga, neck and shoulders, waist and back, dream.
Rotation speed of the rollers		Press this button to increase the rotation speed of the rollers.
		Press this button to decrease the rotation speed of the rollers.
Backrest tilt adjustment		Press and hold this button to adjust the backrest lift, release the button to fix the current backrest tilt angle.
		Press and hold this button to adjust the backrest tilt, release the button to fix the current backrest tilt angle.
Roller foot massage		Press this button to activate/deactivate the roller massage function and toggle the rotation speed of the rollers.
Timer		Press this button to set the massage time. You can set the massage time of 15/20/25/30 minutes.
NECK & SHOULDERS		Press this button to activate/deactivate the shoulder and neck roller massage.
		In the neck and shoulder massage mode above, press this button to toggle between clockwise and counterclockwise rotation of the rollers.
WAIST AND BACK		Press this button to activate/deactivate the waist and back roller massage.
		In the waist and back mode above, press this button to toggle the rollers between clockwise and counterclockwise rotation.
Air-compression massage		Press this button to turn the shoulder, arm, hip, calf, and foot air cushion function on or off.
The intensity of air-compression massage		Press this button to increase the intensity of the air-compression massage.
		Press this button to decrease the intensity of the air-compression massage.

▶ SETUP

INSTALLATION

1. Remove Chair and all Parts from their Packaging

- ▶ Remove any protective wrapping. Check to make sure that all parts are present.

2. Installing the Legrest

- ▶ Take the nuts and bolts from the accessories bag.
- ▶ Align the screws "E" at screw holes "A" and "B", and tighten the screws.

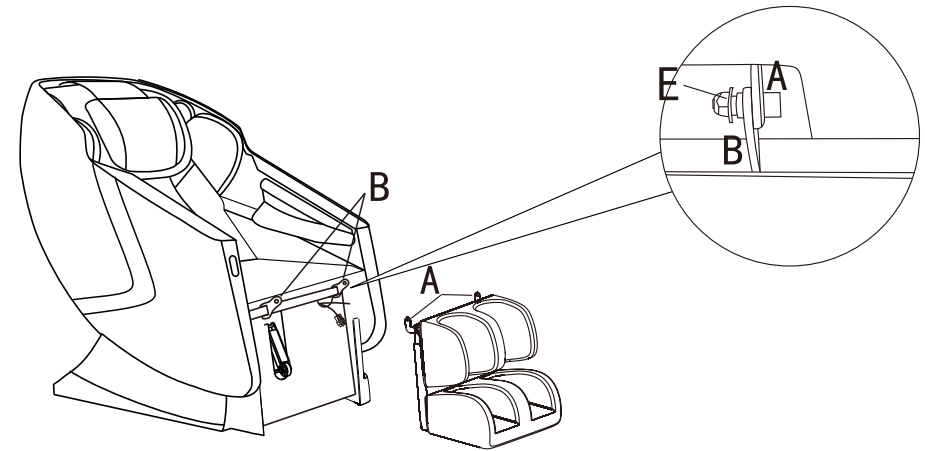

- ▶ Lift the Legrest by reclining the chair. Turn off the power switch and remove the power cord. Attach the corresponding connectors to the ports located on the back of the Legrest.

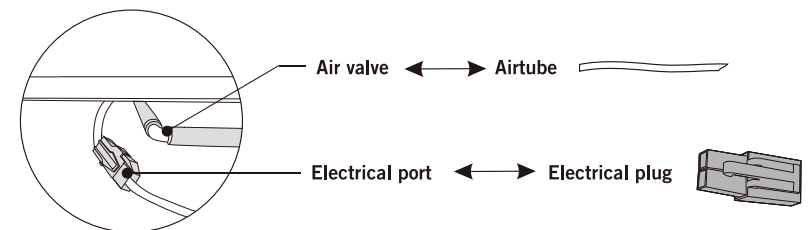

▶ SETUP

3. Install Cushion

- ▶ Prepare the seat cushion and put it in the chair (the air hose faces inward).
- ▶ Connect the cushion air hose to air hose in the seat frame

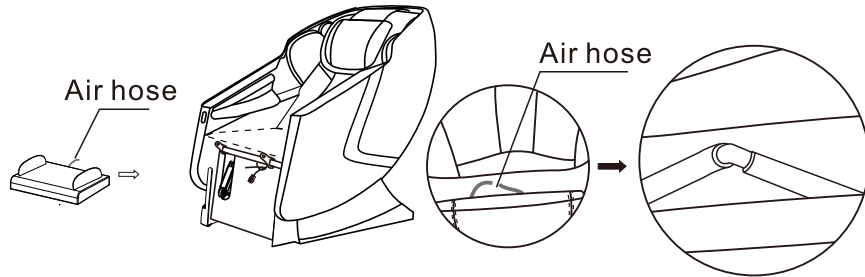

- ▶ Connect the wire of the heater plug from the backrest to underneath of the seat (Fig2)
- ▶ Connect the backrest and the seat by zipper. (Fig 3)

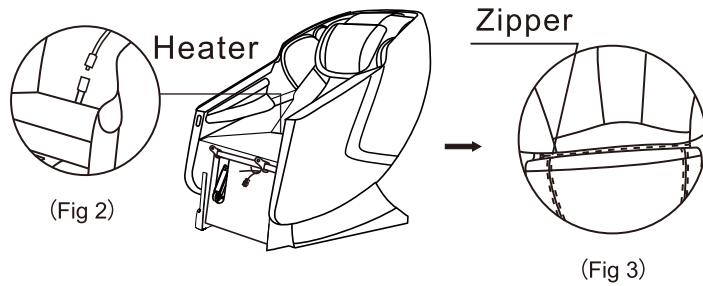

3. Install Backrest Pad and Pillow Pad

- ▶ Attach the upper backrest pad to the backrest with zipper.
- ▶ Remove the cloth on the velcro, then attach the pillow and backrest with velcro.

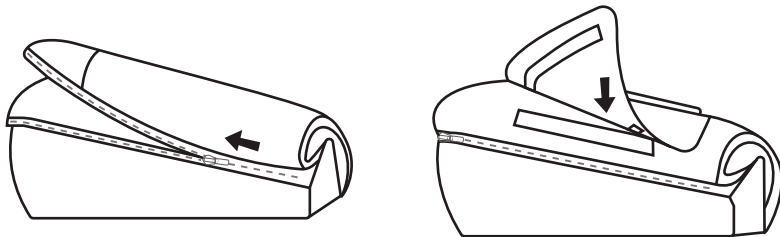

▶ SETUP

5. Power Supply

- ▶ After all parts are assembled, please insert the power cord into the power socket, and then turn on the switch.
- ▶ Press the power button on the remote to start massage.

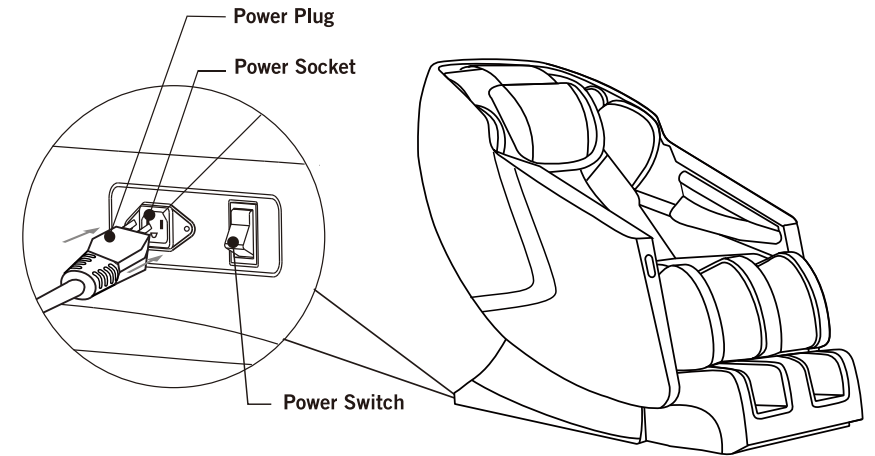

BLUETOOTH FEATURE

This unit comes with Bluetooth capacity for access to audio devices. Make sure that your audio device is compatible with the audio system on this chair. Then play music of your choice while enjoying a luxurious massage.



Pairing your audio device:

- ▶ Make sure that your bluetooth is turned on in your audio device.
- ▶ Search for device and connect.

▶ SETUP

MOVING THE CHAIR

Make sure that the backrest is in its highest upright position. Shut off the power and unplug the power plug from the electrical outlet. Standing behind the back of the chair, grasp its backrest and tilt it downward, so that the front of the chair rises off of the floor. Push the chair to the location you desire.

- ▶ For safety, do not place the chair in a space with excess heat or humidity.
- ▶ Avoid placing the chair in a location with intense direct sunlight, which can cause the leather to fade, discolor, or dry out.
- ▶ Optionally, place a mat or carpet under the base of the chair to protect floors.

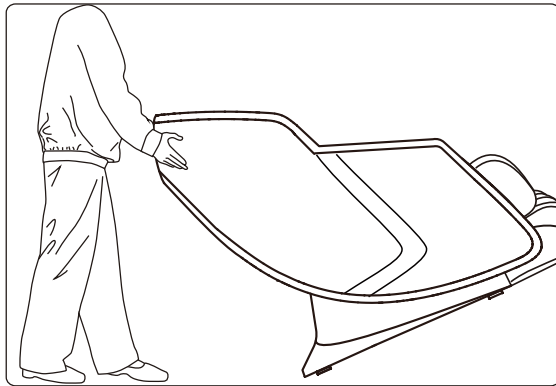

CAUTION

- ▶ Do not attempt to move the chair while someone is still sitting on it. While moving the chair, always grasp its backrest. Do not try to move the chair by grasping its armrests.
- ▶ Before plugging it in, inspect the entire power cord and plug for any possible damage. Make sure that no electrical wires are exposed. Make sure that the power supply switch is turned OFF before inserting the power plug into a wall outlet.

▶ SETUP

MASSAGE CHAIR PLACEMENT

When looking for a location to place your massage chair, keep following in mind:

- ▶ The chair takes up significantly more space when stretched out, than when in an upright position. With the chair upright, allow at least 20 inches of open space behind the backrest, and at least 20 inches of space in front of the footrest.
- ▶ To prevent wearing out the floor beneath the chair, we advise placing some cushioning material, such as a rug or plastic mat, underneath the chair.
- ▶ To prevent possible electrical leakage, do not place the massage chair in or near a damp environment, such as a bathroom.
- ▶ To prevent fire or damage to its leather material, keep the massage chair away from any sources of heat (such as a stove or furnace).

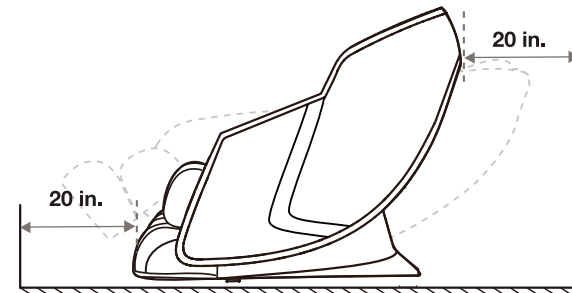

WHERE TO USE THE UNIT

- ▶ Ensure adequate space to recline.
- ▶ Do not expose the massage lounger to direct sunlight or high temperatures, such as in front of heating sources, because this can cause discoloration or hardening of the synthetic leather.
- ▶ Place the unit on a mat to prevent floor damage.
- ▶ When placing a mat under the unit, The size of the mat should be sufficient
- ▶ Install the unit near a power socket.

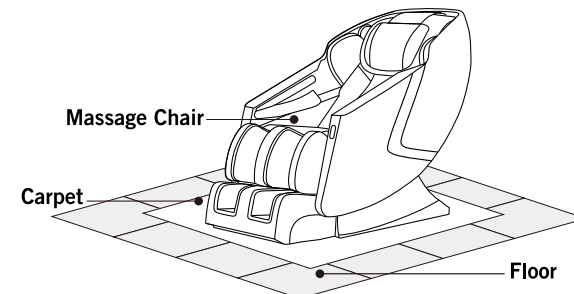

▶ SETUP

BEFORE USING THE MASSAGE CHAIR FOR THE FIRST TIME

- ▶ Make sure there are no objects, people, or pets in the vicinity of the unit.
- ▶ Check that the chair has room to recline. Use the controller to lower the backrest to its furthest outstretched position. Raise the footrest to its highest position. Make sure that sufficient open space surrounds the chair on all sides. Make sure that the leg rest is properly connected to the main part of the chair.
- ▶ Press the power button to return the chair to its original, upright position.

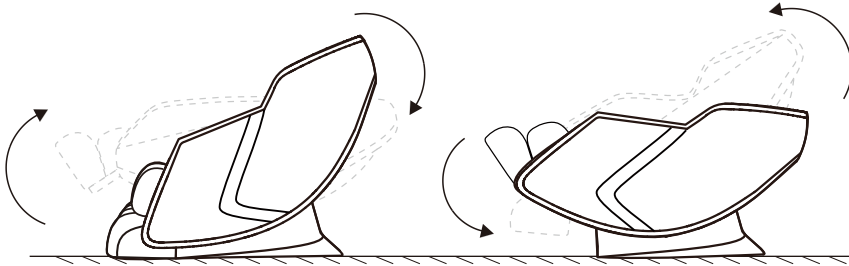

⚠ CAUTION

- ▶ Do not sit on the massage chair while the footrest is rising.
- ▶ To avoid possible damage, do not suddenly load the footrest with heavy weight.
- ▶ Do not allow children to play with this massage chair. If controls are tampered with, accident or injury arising from the power supply box may result.
- ▶ After your massage finishes its cycle, switch off power and remove the power plug from its wall outlet.
- ▶ Avoid operating this chair during rain and thunderstorms.
- ▶ When the chair is not in use, switch off power and remove the power plug from its wall outlet.
- ▶ Avoid dragging this chair across surfaces that can easily be damaged, such as wooden or carpeted flooring.
- ▶ To prevent electric shock, do not operate this chair within damp environments.
- ▶ Do not place this chair near a stove or other significant sources of heat.
- ▶ Do not expose the chair to prolonged sunlight. Damage to its leather cover may result.
- ▶ Do not hold the footrest massage section when moving the unit. If this is not observed, the section may slide as you move the unit, and injuries may occur.
- ▶ Do not drag or push the unit in an installed state. Protect your floor (place a mat or similar) when moving the unit on its wheels to avoid damage to your floor.

▶ SETUP

GROUNDING INSTRUCTIONS

This product must be grounded. If it should malfunction or breakdown, grounding provides a path of least resistance for electric current to reduce the risk of electric shock. This product is equipped with a cord having an equipment-grounding conductor and a grounding plug. The plug must be plugged into an appropriate outlet that is properly installed and grounded in accordance with all local codes and ordinances.

⚠ DANGER

- ▶ Improper connection of the equipment-grounding conductor can result in a risk of electric shock.
- ▶ Check with a qualified electrician or service person if you are in doubt as to whether the product is properly grounded.
- ▶ Do not modify the plug provided with the product. If it does not fit the outlet, have a proper outlet installed by a qualified electrician.
- ▶ This product is for use on a nominal 120-V circuit and has a grounding plug that looks like the plug illustrated in sketch below.

TURNING ON THE POWER

- ▶ Plug the power cord into the port at the base of the chair.
- ▶ Plug the three-pronged power plug into a properly-grounded three-prong power outlet.
- ▶ Flip on the power supply switch, located on the back of the massage chair, at the base of the backrest.

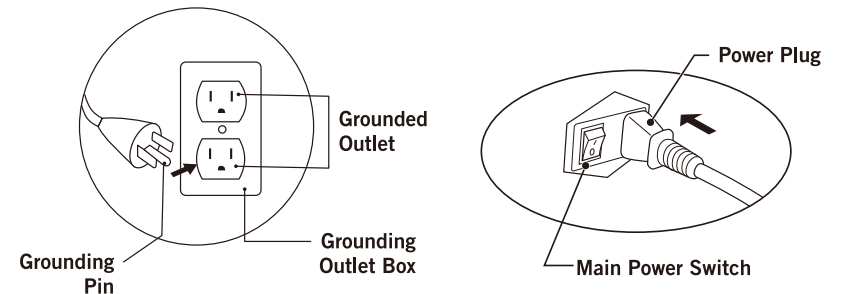

Improper use can result in electric shock or damage to the chair.

▶ PRODUCT STORAGE AND MAINTENANCE

CLEANING

- ▶ Before cleaning, switch off power and remove the power plug from the wall outlet.
- ▶ Dip a soft, cotton cloth in neutral detergent and wring dry. Use it to wipe the pillow cushion, back cushion, armrests, footrests, and any plastic parts of the chair.
- ▶ Use a piece of wet cloth (without detergent) to re-wipe the pillow cushion and back cushion. Place them in a well-ventilated location for drying.
- ▶ Use a soft, dry cloth to re-wipe the armrests, footrests, and any plastic parts of the chair.
- ▶ Use a soft, dry cloth to wipe the controller, and the power supply box.

CAUTION

- ▶ Before any maintenance, always disconnect the power plug from the wall outlet.
- ▶ To avoid electric shock, never touch the power plug with wet hands.
- ▶ When cleaning the back cover of the massage chair, do not allow any detergent to seep into the power supply box.
- ▶ Do not use abrasive chemicals, such as benzene or alcohol, to clean this chair. Damage to the chair may result.
- ▶ Do not apply an iron or any other heated device to the chair.

STORAGE

When not in use, be sure to switch off power and detach the power plug from the wall outlet. Before putting into storage, wipe off all accumulated dirt and dust from the surface of the chair. Cover the entire surface of the chair with a dust cover (not included).

CAUTION

- ▶ Do not store the product under direct sunlight, nor in a location with high temperatures. Doing so may cause the upholstery to fade.
- ▶ Do not allow massage chair to remain in contact with vinyl or wallpaper for extended periods of time as this could lead to discoloration.

MAINTENANCE

Upon detecting any of the following conditions during daily use, immediately turn off power, disconnect the power plug from the wall outlet, and contact an authorized repairman:

- ▶ A burning smell
- ▶ The power cord feels hot
- ▶ Any other abnormal symptoms
- ▶ The cord is plugged in and the power switch flipped on, but no functions operate.

▶ TROUBLESHOOTING & TECHNICAL SPECIFICATIONS

	Problem	Check the Following:	Explanation/Remedies
1	During operation, the controller is working but not the massage chair.	N/A	The massage chair could be overheating. It will automatically cool down before it will resume its normal condition. Please turn OFF the power and allow the chair to cool down for 30-50 minutes.
2	Operation fails to start.	Has the power plug been pulled out of the wall outlet? Is the power switch in the "OFF" position? Has the fuse blown out?	Connect the power plug securely into the wall outlet. Switch power to the "ON" position. Replace the fuse with another of the same type.
3	Seat or calf airbags fail to operate.	Have any of the air tubes been blocked?	Clean out the air tubes inside the chair.
4	During operation, both the controller and the massage chair stop working.	Check if timer is complete.	If the set-time in the timer is complete, please press the timer function again to resume operation. Switch "OFF" the power and switch it "ON" again to activate the chair.

If problems persist after applying the suggestions above, turn off power and remove the power plug from the wall outlet. Then contact the manufacturer for maintenance and repair.

Product model: CF-9212

User weight limit: 220 lbs

Rated voltage: 120 V~

Rated frequency: 60 Hz

Rated power: 100W

Safety design: Class I

▶ WARRANTY

If the product(s) is damaged or defective within a reasonable time, COMFIER offers the warranty as below.

Period	Return for refund	Return for replacement	Who paid shipping?
Within 30 Days	Yes	Yes if undamaged	Comfier
31- 90 Days	Yes after being justified	Yes after being justified	Comfier
91 Days - 1 Year	No	Yes after being justified	Buyer
1 Year - 3 Years	No	Only to buyers who have received extended warranty	Buyer

Comfier warrants the product to be free from defects in workmanship and materials, under normal use, for a period of 12 months from the original invoice date, except as noted below. Comfier products can be repaired or replaced within warranty period or returned for refund within 90 days if the products break down in the period of proper use.

The warranty extends only to consumers, NOT to any retailers or resellers. This warranty is effective only if the product is purchased and operated in the country in which the product is purchased. Warranty claims for product defects, unless extended warranty is registered, expire 12 months from the purchase day. Warranty claims CANNOT be processed for items that have exceeded the warranty period. The warranty does NOT cover the replaced, refurbished product. The warranty does have other limitations as below "Warranty Limitations". To obtain warranty service on Comfier products, follow "Warranty Claim Procedures" below.

Warranty Claim Procedures:

1. Any product the customer believes is defective and seeks for warranty, the customer must provide to Customer Support:
 - a) Valid proof of purchase (see below the definition of valid proof of purchase);
 - b) Pictures and/or description are required to claim defective merchandise;
 - c) Model number and Series Number label attached to each product
2. If the warranty claim is justified by Comfier Customer Support, customer(s) will obtain from Comfier a Warranty/Return Authorization Number (RMA Number)
3. Comfier reserves the right to specify that items be returned to the designated warehouse for inspection or be inspected by our representative in the field or be retained by customer.
4. Any claim for defective merchandise returns must be packed in original packaging
5. The item(s) will be repaired or replaced or a refund credit will be issued once the item(s) are delivered. When returning items with RMA# and a prepaid shipping label provided by Comfier, Comfier takes responsibility for any damage or loss incurred in transit.

Valid proof of purchase under this Warranty:

Order numbers from online purchases made through Comfier official store (www.comfier.com) or Comfier's direct-authorized resellers, currently only at Amazon/eBay/Walmart. For product(s) obtained from other Channels, please contact the customer service of the Channel directly for appropriate solution.

▶ WARRANTY

Warranty Limitations(this warranty does not include):

Normal wear and tear; Any condition resulting from other than ordinary residential wear or any use for which the product was not intended, such as use in rental or contract trade or commercial use; Any condition resulting from incorrect or inadequate maintenance or care; Damage resulting from misuse, abuse, negligence, accidents or shipping damage, exposed to environmental conditions temperatures, water, improper operation,improper installation, improper use of electrical supply; transportation damage; theft,vandalism or;Damage resulting from the attachment or modification of any unauthorized accessories;Fail to show the valid proof of purchase;Lost or stolen products;Items that have expired their warranty period; No quality-related issues (after 30 days of purchase);Free product/ Gift offer by Comfier; unauthorized repairs or modification; Replaced or refurbished product.Dissatisfaction due to buyer's remorse (after 30 days of purchase).

Refund Procedures:

(Refer to <https://www.comfier.com/pages/return-policy>)

Warranty Disclaimer

THE WARRANTY PROVIDED HEREIN SHALL BE THE SOLE AND EXCLUSIVE WARRANTY. COMFIER SHALL HAVE NO LIABILITY FOR, AND EXPRESSLY DISCLAIMS ANY WARRANTY OR AFFIRMATION OF FACT, EXPRESS OR IMPLIED, OTHER THAN AS SET FORTH IN THIS WARRANTY STATEMENT, INCLUDING, WITHOUT LIMITATION

- (1) THE IMPLIED WARRANTIES OF MERCHANTABILITY AND FITNESS FOR A PARTICULAR PURPOSE;
- (2) ANY WARRANTY OR AFFIRMATION OF FACT RELATED TO MISUSE, IMPROPER SELECTION, RECOMMENDATION, OR MISAPPLICATION OF ANY PRODUCT; AND
- (3) ANY WARRANTY OR AFFIRMATION OF FACT THAT THE CATALOGS, LITERATURE AND WEBSITES IT PROVIDES ACCURATELY ILLUSTRATE AND DESCRIBE PRODUCTS.

Comfier reserves all the right for final interpretation of these Terms of Warranty and Return Policy above and the aright to change, modify, add or remove portions of these terms at any time without prior notification.

Extend Warranty for Free

- 1) Enter the following URL or scan the QR code below to find COMFIER facebook page and like it, enter"Warranty" to messenger to extend your warranty from 1 year to 3 years.



<https://www.facebook.com/comfiermassager>

- OR 2) Send message"Warranty" and email us supportus@comfier.com to extend your warranty from 1 year to 3 years.