

OSCAR

Solar air collector

Catalogue

Function, Product,
Advantage, Tips,
About Oscar

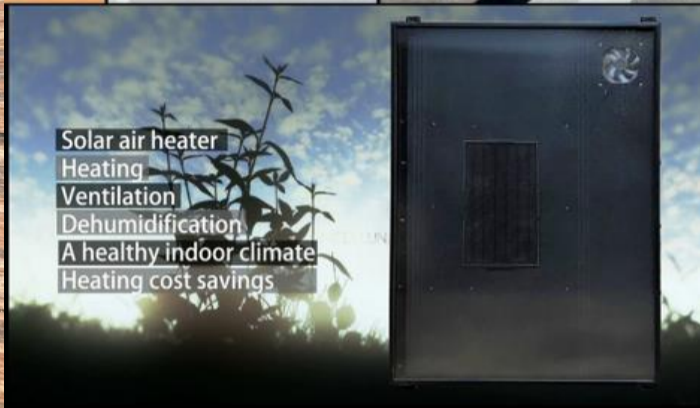

Function introduction

The sun shines on the special heating absorption board and the surrounding air absorbs heat. Nakoair solar air collector/ heater takes in air at the bottom of panels, and through a special construction, the air is heated in the sun catching the most heat and then delivered into the room. The heated fresh air is blown into the house by fan, driven by photovoltaic panel.

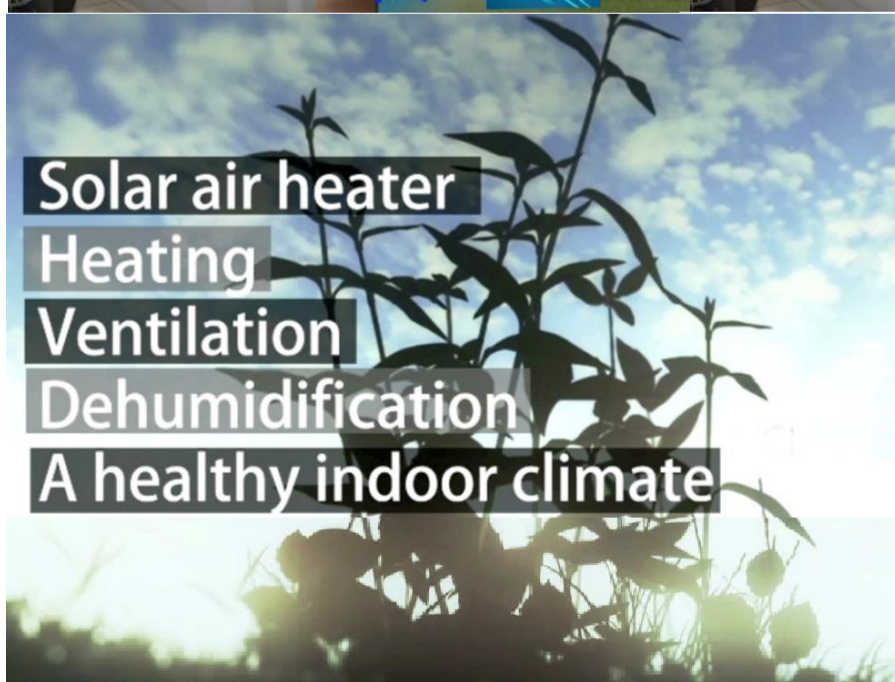
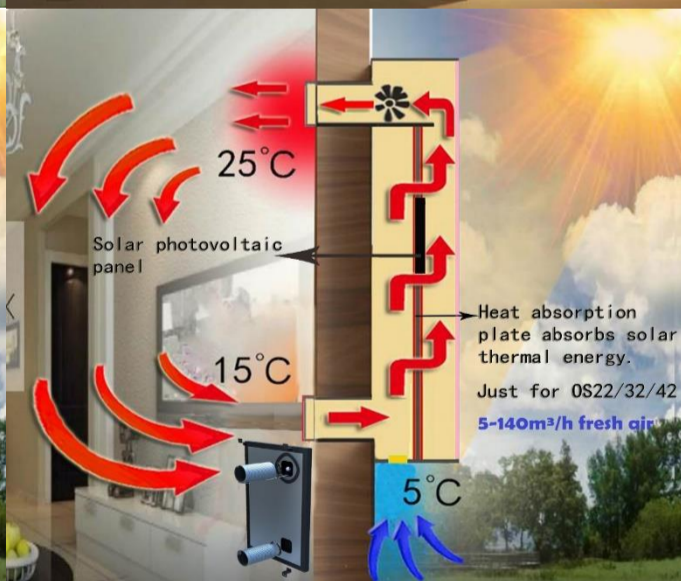
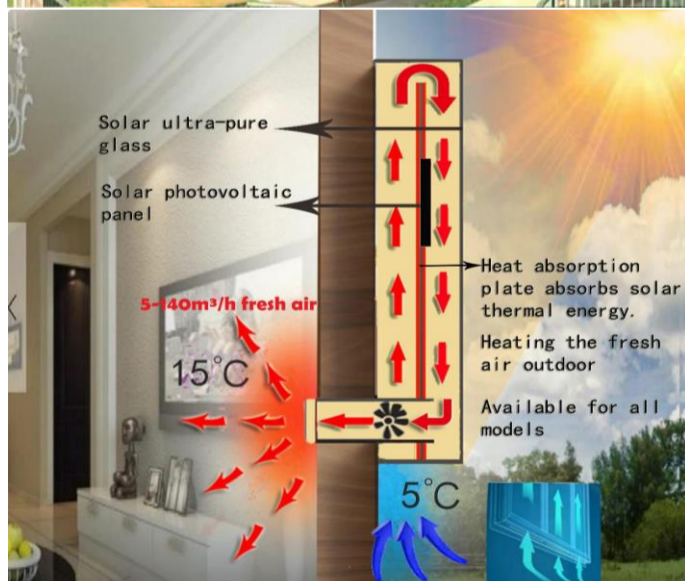
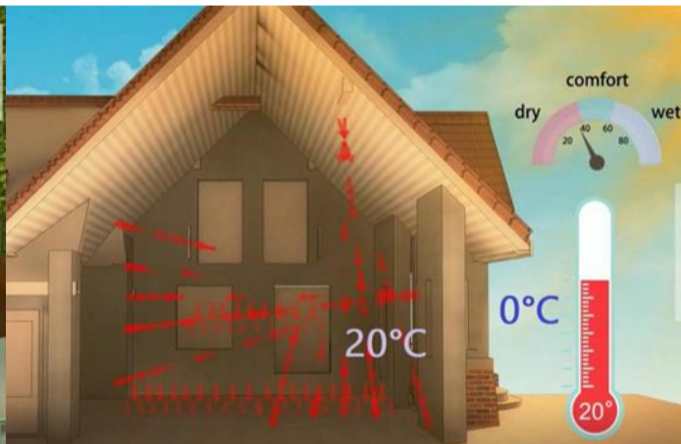
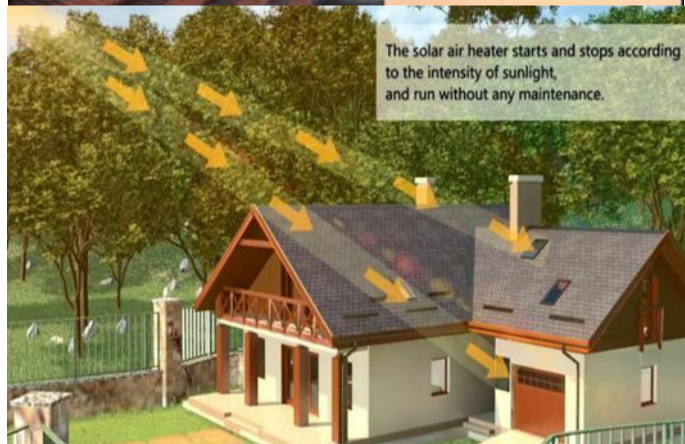

Solar ultra-pure tempered glass
 Solar photovoltaic panel
 Heat absorption plate absorbs solar thermal energy



Solar ultra-pure tempered glass
 Solar photovoltaic panel
 Heat absorption plate absorbs solar thermal energy



Annual Heating Delivered (9 months) ≈ 700 kWh/m²

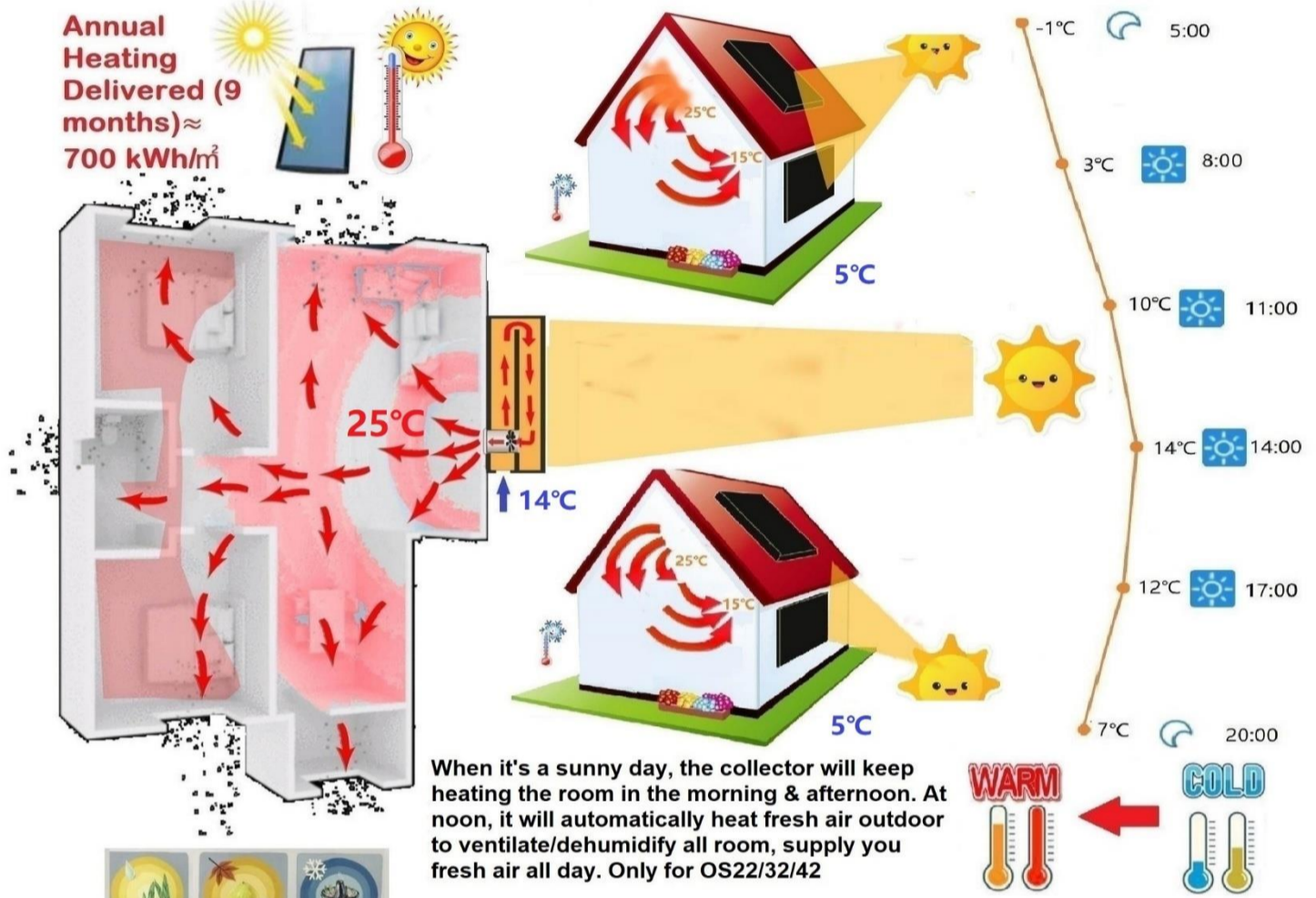

Spring fall winter

Automatic ventilation when outdoor temperature is higher than indoor temperature.

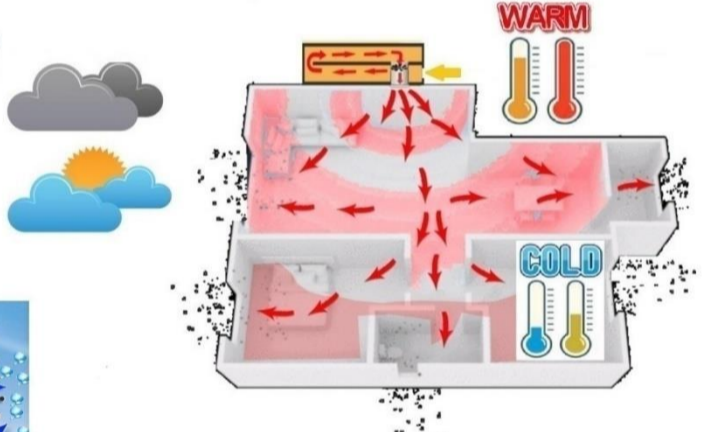
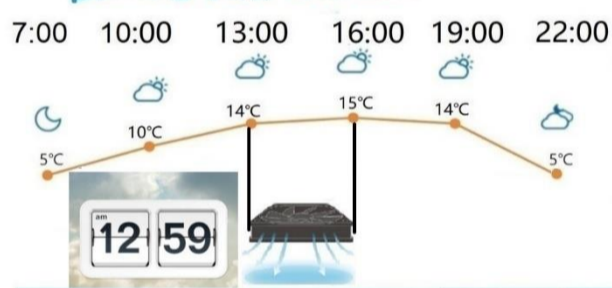

Ventilation for 1-3h, when the outdoor temperature reaches its highest level at noon in spring / autumn / winter.

5V DC
 The annual electricity consumption is less than 10 kWh.

Summer evening

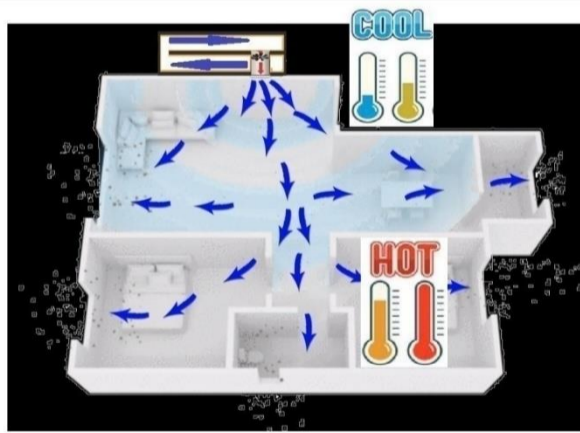

Automatic ventilation when outdoor temperature is lower than indoor

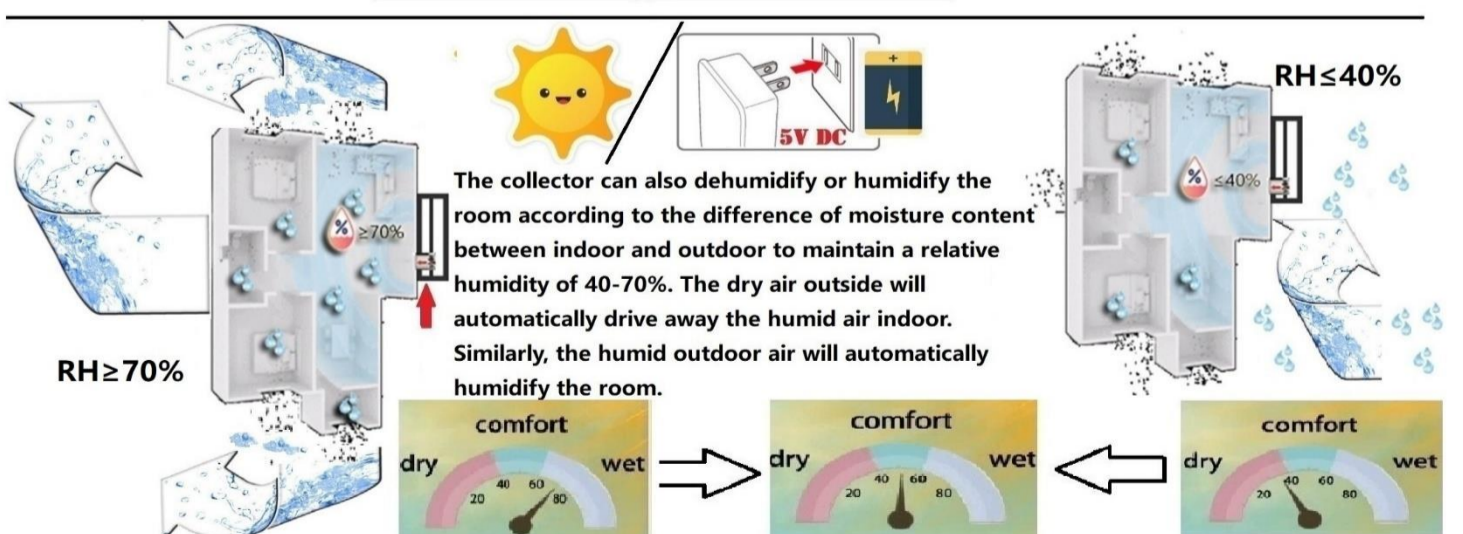

The collector can also dehumidify or humidify the room according to the difference of moisture content between indoor and outdoor to maintain a relative humidity of 40-70%. The dry air outside will automatically drive away the humid air indoor. Similarly, the humid outdoor air will automatically humidify the room.

Ventilation, heating, dehumidification or humidification. Solar collector with LCD thermostat, provides you with a healthy and warm home and automatically processes indoor air. Simple operation, thoughtful air management expert!

Nakoair solar air collectors always provide you with a warm and healthy home!

When it's a sunny day, the collector will keep heating the room in the morning & afternoon. At noon, it will automatically heat fresh air outdoor to ventilate/dehumidify all room, supply you fresh air all day. This function is only applicable for OS22/32/42. Ventilation can be extended at noon in spring / autumn.

Even in rainy or cloudy weather, the collector will provide fresh air to you by automatically switching to electricity, and the power consumption is less than 10kWh per year. When the outdoor temperature reaches its highest level at noon in spring / autumn / winter, or when the weather is cool in the summer evenings, it will ventilate the room to improve the indoor temperature; keep you warm in winter and cool in summer. The collector can also dehumidify or humidify the room according to the difference of moisture content between indoor and outdoor to maintain a relative humidity of 40-70%. The dry air outside will automatically drive away the humid air indoor. Similarly, the humid outdoor air will automatically humidify the room.

● **Heating**

The built-in solar powered fan makes air transport which results in a contribution to heat the building and thus a saving on heating bills. Regular ventilation without power consumption. On a sunny day, the temperature of the injected air is approximately 5-40°C higher than the outdoor or indoor air inlet temperature.

In addition, the air temperature on the sunny side usually rises more than 10°C under the big sun.

● **Ventilation**

The fresh air of solar air heater squeezes the turbid air out of the room, keeping the air fresh and oxygen-rich.

Depending on the models, approx. 5 to 140m³/h dry, warm air is blew into the room. In the case of cloudy days without sunlight, the room can also be properly ventilated. Humid air is drove out of the room through a built-in valve or the cracks and crevices of the building.

Ventilation is a key factor to the state of every building. Stagnant indoor air increases the risk of fungi, rot and other unwanted consequences.

Preserve the value of your vacation home while getting fresh air – for free and all year round!

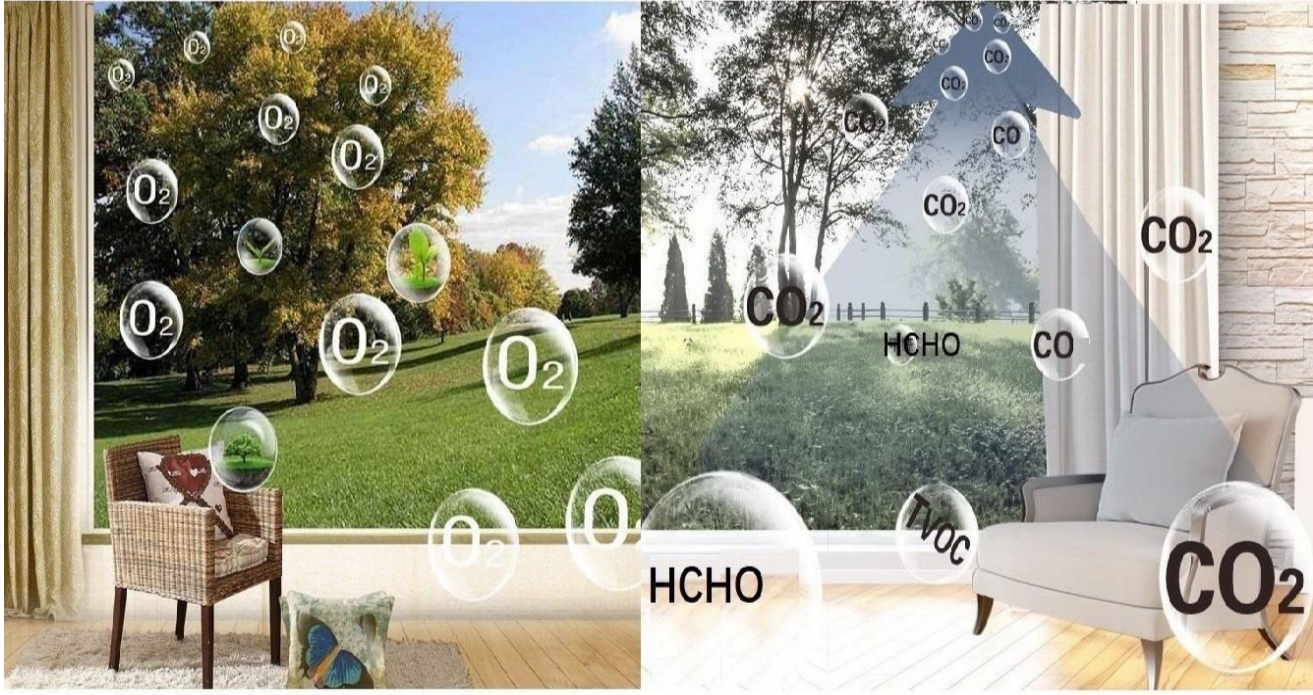

Fresh air of Solar air heater squeezes the turbid air out of the room, keeping the air fresh and oxygen-rich.
Ventilation design standard: minimum fresh air volume per capita: 30m³/h.

FRESH OXYGEN

Increase oxygen, reduce CO₂, and care for health, do not feel oppressed.

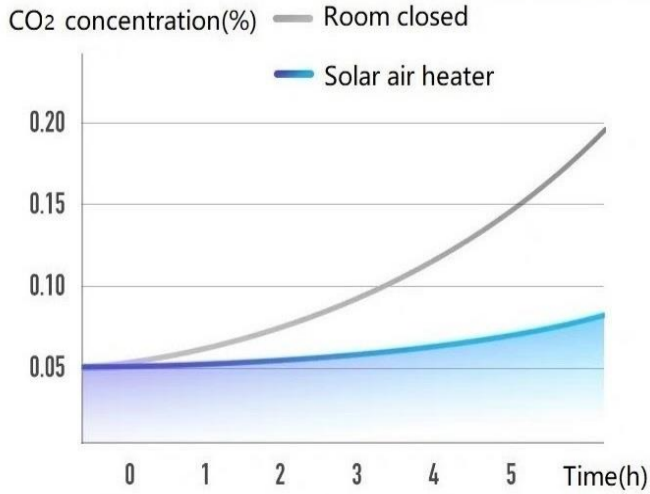

An adult is tested in a 15m² closed room for 6 hours

Dehumidification or humidification

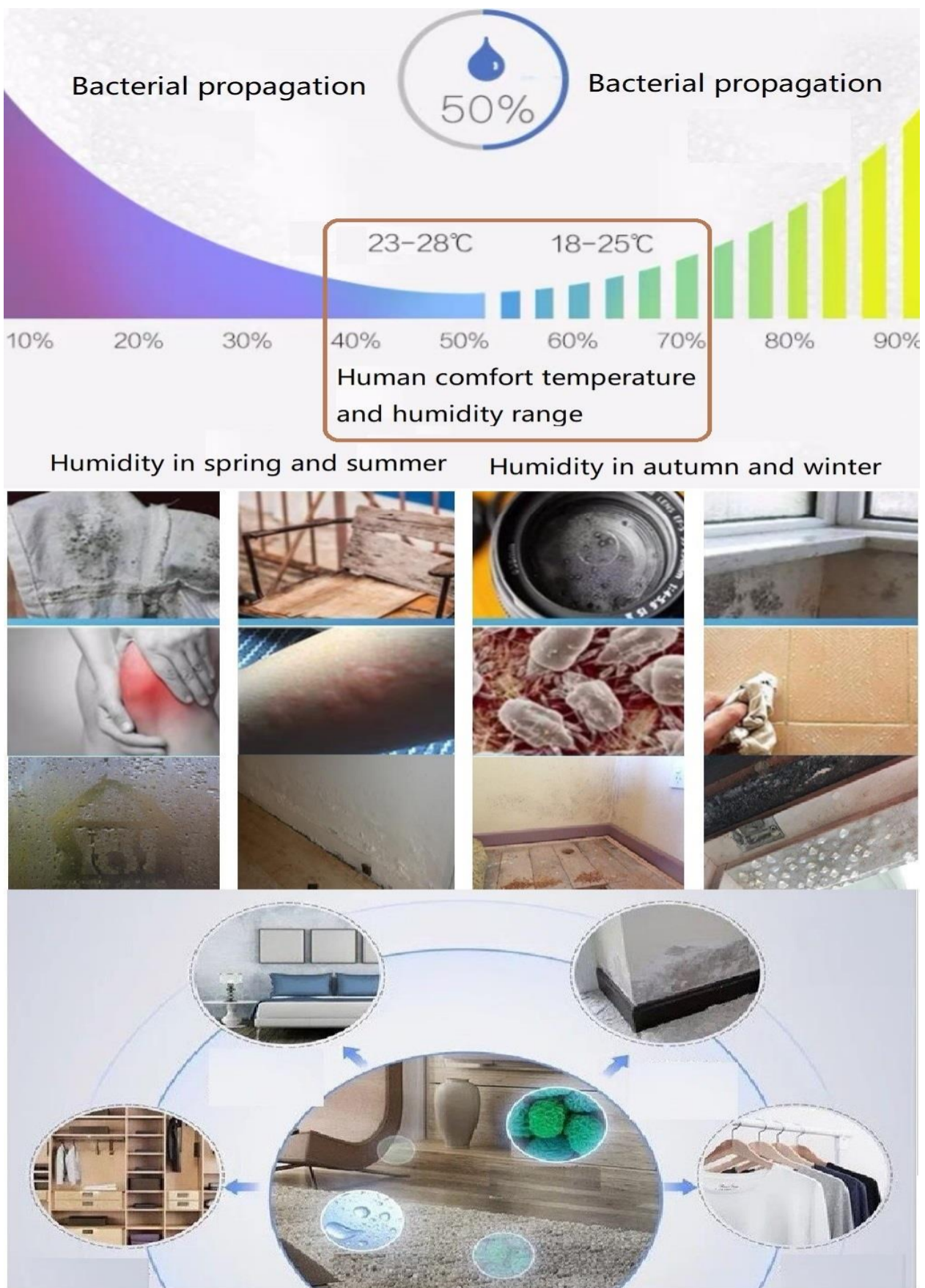

Optimum level (for comfort as well as building quality) is a relative humidity (RH) of 40-70 %.

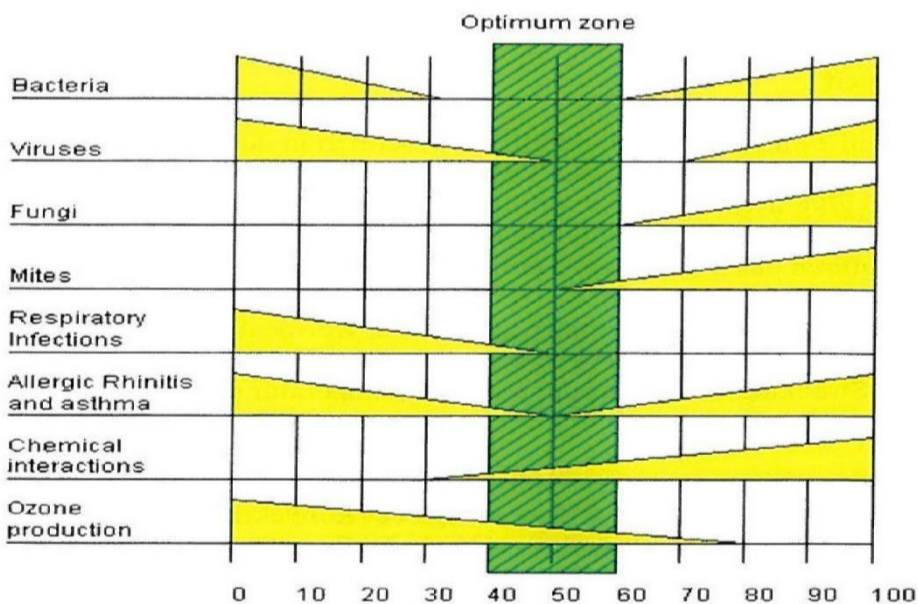

Source: ASHRAE Journal (The American Society of Heating, Refrigerating and Air-Conditioning Engineers)

The OSCAR solar air heater in the basement can fully solve the moisture in the basement and extend the service life of the indoor structure and appliances. Basement problem: damp basement. One of the earliest signs of wetness in the basement was a stale smell. Humidity can quickly damage items stored in the basement, such as textiles, cardboard boxes or furniture. In addition, lack of regular ventilation can cause mold and harmful fungi. To make the room suitable again, it must be regularly heated, mechanically dehumidified and ventilated. Electric dehumidifiers will frost below 15 °C, so the dehumidification effect will be worse. In addition, the dehumidifier requires refrigeration and consumes a large amount of power. This often results in high operating costs.



The dry climate indoor can easily cause virus and bacteria to multiply and spread. In addition, the dry air takes away water from the body, making them feel dry, feverish, depressed, coughing, hoarse, and sore throat.

Applications
 in holiday cabins
 in residential and commercial buildings
 in the cottages and summer residences
 in caravans and tents
 in conservatories
 in cellars and storage areas
 in football and other sports cabins
 in areas without electrification



Product Information



OS32



OS30



OS22



OS20



OS10

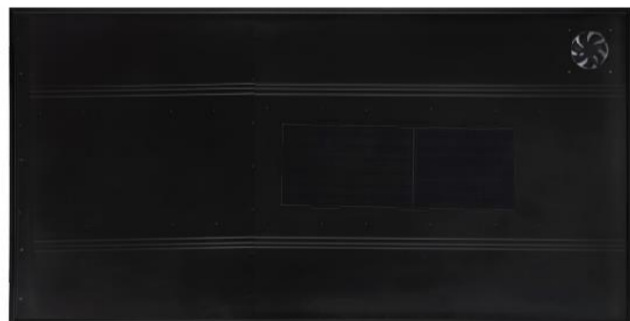

OS40



OS42

OS10/OS20/OS30/OS40:

Heating outdoor fresh air: available in spring, autumn and winter.



OS22/OS32/OS42: 2-in-1 function

Heating outdoor fresh air: suitable for all models.

Heating indoor air circularly mold: can keep heating the room air and increasing the room temperature, and can keep away from any wet or cold or smog air. This mode is the best way to heat the room. Applicable to OS22/32/42.

When the outdoor temperature is too low, just open the air inlet indoor to keep heating the indoor air. Just close the air inlet indoor to introduce and heat the fresh air outdoor.

Nakoair solar air collectors always provide you with a warm and healthy home!

Product detail for aluminum alloy heater

Model	OS10	OS10H	OS20	OS22	OS30	OS32	OS40	OS42
Appro room area	10m ²	15 m ²	40m ²		60m ²		90m ²	
Maximum air volume	42m ³ /h	88m ³ / h	88m ³ / h	98m ³ / h	105m ³ / h	113m ³ /h	128m ³ /h	135m ³ /h
Time for air change	Approximate 2 hours							
Heating efficiency	69%	77%	73%	77%	70%	74%	69%	72%
Sun intensity performance (w/h/set)	265W	300W	520W	550W	800W	840W	1310W	1380W
Total Annual heat supply kWh/m ²	690	770	730	770	700	740	690	720
Estimated energy supplement year	250kWh	280kWh	525kWh	550kWh	777kWh	820kWh	1359kWh	1418kWh
Temperature rise approx.	8° C	5° C	15° C	16° C	25° C	26° C	30° C	32° C
Dehumidification capacity (high humidity)			0.3L/hour		0.5L/hour		0.8L/hour	
Noise level	39db	45db	45db		48db		50db	
Product size (cm)	71x52x6.2	52x71x6.2	101x72x6.2		121x92x6.2		197x100x6.2	
Carton size(cm)	90x57x9	57x90x9	124x78x9		129x98x9		204x106x9	
Roof mounting kit	Not applicable				120x17 x12cm 8.2kg		112x28x16cm 12kg	
Product area	0.37 m ²	0.37 m ²	0.72 m ²		1.11 m ²		1.97 m ²	
Solar photovoltaic panel power	8watt	12watt	12watt		18watt		28 watt	
Fan 2 ball	12V 3.6W 92*92*25mm	SUNON 12V, 3.4 watt 120*120*25mm					SUNON 12V, 5.4 watt 120*120*25mm	
Net weight	7kg	7kg	12kg		15kg		27kg	
Gross Weight	8kg	8kg	15kg	16kg	20kg	21kg	34kg	35kg
Special heating absorption board	Special anodic aluminum oxide, texture nano heat insulation coating, high absorption, low reflection.							
Frame	Exclusively for open air, anti-UV texture coating aluminum alloy							
Coating	Low iron patterned solar tempered glass, up to 92% transmittance							
	White diffuser Flange for indoor wall; Tubes for wall lead-in, gaskets, screws etc.							

The price includes a mechanical thermostat and all necessary mounting accessories. Extra cost will be charged if customer needs LCD thermostat and automatic air outlet. Reducing the air volume can increase the air temperature into the room. Increasing the air volume can increase the heating efficiency and dehumidification effect. If it is a frequently used room such as residential, or a room with high humidity such as a basement, it is recommended to buy a larger one. For frequently used rooms, it is recommended to purchase the OS22/32/42 with LCD thermostat and automatic vent.



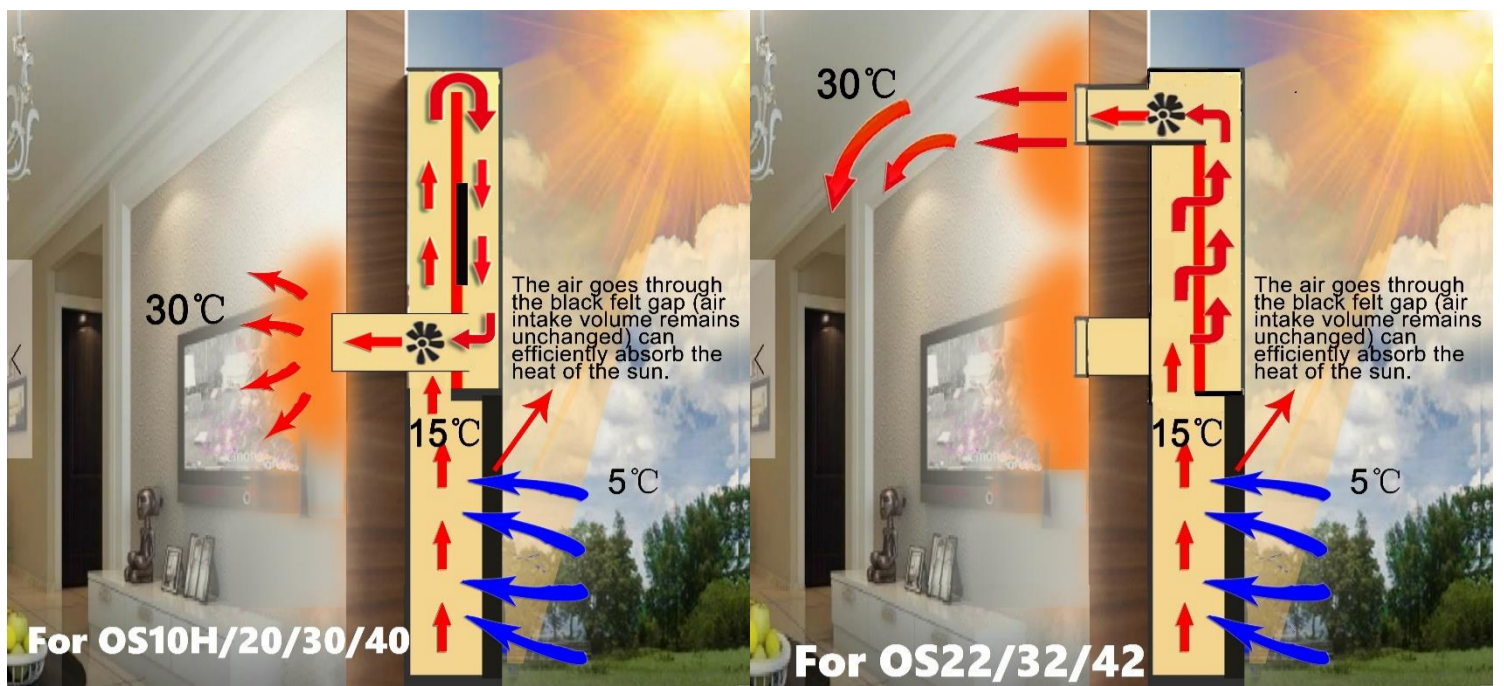

The special felt cover can be spliced with aluminum alloy collector (OS10H/20/22/30/32) and installed on a flat roof or wall. The air through the black felt gap (air intake volume remains unchanged) can efficiently absorb the heat of the sun, thereby increasing the temperature of the outdoor fresh air entering the room. As long as the felt cover is spliced, the temperature of the fresh air entering the room can be increased: F7----about 10°C; F11----about 15°C.

After a long period of outdoor dust and rain test, the air intake volume is reduced by up to 3%. It can effectively filter Dust and become clean after rain washing, no maintenance is required. The service life is more than 5 years.

Felt cover	F7	F11	F11H(horizontal)
Can't be used alone	for OS20/22	for OS30/32	Just for OS32
Appro temperature rise	15° C	25° C	25° C
Max performance(w/h)	520W	800W	800W
Estimated energy supplement	525kwh/unit/year	770kwh/unit/year	770kwh/unit/year
Product area	0.7 m ²	1.1 m ²	1.1 m ²
Product size(cm)	101x72x6	121x92x6	92x121x6
Carton size(cm)	101x10x10	118x12x12	118x12x12
Net weight	2KG	3KG	3KG
Gross Weight	3KG	4KG	4KG

Introduction and images for regulators or switches



Mechanical thermostat:

The standard configuration can only work in the sun, and cannot be connected to electricity. Ventilator will stop working when the room temperature reaches the set value (eg. 25°C).

New LCD thermostat: Ventilation and dehumidification or humidification are available even on cloudy or summer nights. Smart curved touch screen: the perfect combination of art and technology!

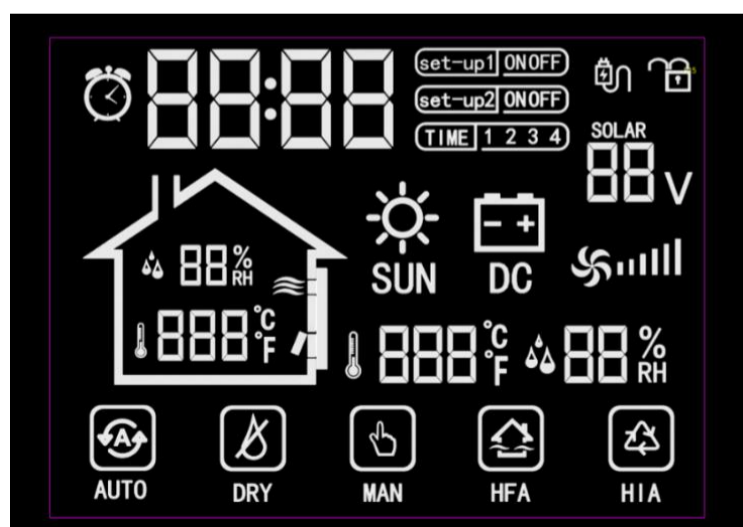

Ventilation, heating, dehumidification or humidification. Solar collector with LCD thermostat, provides you with a healthy climate and automatically processes indoor air. Simple operation, thoughtful air management expert! There are five modes: automatic, humidity control, manual, heating and ventilation, continuous heating of indoor air. Can detect indoor and outdoor temperature and humidity, moisture content in the air. Automatically switch between solar and electrical energy. Ventilate regularly to purify the air every day. As long as the collector does not work, the air vents automatically close, completely isolating the outdoor cold air.

Heating in the sun in the spring/ fall/ winter			
LCD Thermostat	When presetting temperature is higher than indoor temperature.		
Automatic mode	Sunshine-12am	12:00 am--- 3:00 pm	3pm--no Sunshine
Only for OS22/32/42	Keep heating indoor air circularly	Heating outdoor fresh air (Spring and autumn can increase ventilation time)	Keep heating indoor air circularly
For OS20/30/40	Just heating outdoor fresh air in the sun		
In the process of heating indoor air, if the following conditions occur, the device will automatically turn to heat the outdoor fresh air.			
1. Outdoor air (moisture content) is dryer than indoor		and indoor relative humidity $\geq 75\%$	
2. Outdoor air is wetter than indoor air		and Indoor relative humidity $\leq 30\%$	
3. When it is detected that the outdoor temperature is higher than the indoor temperature.			
Humidity control mode	Sunshine-11am	11am--- no sunshine	
Only for OS22/32/42	Keep heating indoor air circularly	Heating outdoor fresh air (Spring and autumn can increase ventilation time)	
For OS20/30/40	Just heating outdoor fresh air in the sun		
In the process of heating indoor air, if the following conditions occur, the device will automatically turn to heat the outdoor fresh air.			
1. Outdoor air (moisture content) is dryer than indoor		and Indoor relative humidity $\geq 70\%$ (60%-75%)	
2. Outdoor air is wetter than indoor		and Indoor relative humidity $\leq 40\%$ (30%-45%) ;	
3. When it is detected that the outdoor temperature is higher than the indoor temperature.			
In the process of ventilation, if the following conditions occur, the fan stops working.			
Outdoor air (moisture content) is wetter than indoor air		and indoor relative humidity $\geq 70\%$	
Manual mode	Can set a time period to heat fresh air or air indoor		
Heating fresh air mode	Just heating outdoor fresh air		
Heating indoor air mode	Keep heating indoor air circularly		
Electricity			
LCD Thermostat	All models can only introduce fresh outdoor air to regulate indoor temperature and humidity.		
Automatic mode	In the Spring/Fall/Winter	In the Summer	
Automatic ventilation	When outdoor temperature is higher than indoor.	When outdoor temperature is lower than indoor.	
Ventilation 1-3h from 13pm, keep the room fresh.	Outdoor 5-15°C (adjustable)	Outdoor 15-23°C (adjustable)	Outdoor 23-28°C (adjustable)
	Ventilate for 1h	2 hours	3 hours
Outdoor air (moisture content) is dryer than indoor		and indoor relative humidity $\geq 85\%$	
Outdoor air (moisture content) is wetter than indoor		and indoor relative humidity $\leq 35\%$	
Will ventilate to regulate moisture content indoor			
In the process of ventilation, if the following conditions occur, the fan stops working.			
Outdoor air (moisture content) is dryer than indoor		and indoor relative humidity $\leq 35\%$	
Outdoor air (moisture content) is wetter than indoor		and indoor relative humidity $\geq 85\%$	
Humidity control mode: Indoor relative humidity adjustment range: 30% -45%; 60% -75%.			
Outdoor air (moisture content) is dryer than indoor		and indoor relative humidity $\geq 70\%$	
Outdoor air (moisture content) is wetter than indoor		and indoor relative humidity $\leq 40\%$	
Will ventilate to regulate moisture content indoor			
Manual mode	Can set 2 time periods freely to ventilation.		
Heating fresh air mode	In the Spring/Fall/Winter	In the Summer	
Automatic ventilation	When outdoor temperature is higher than indoor.	When outdoor temperature is lower than indoor.	
Ventilation 1-3h from 13pm, keep the room fresh.	Outdoor 5-15°C (adjustable)	Outdoor 15-23°C (adjustable)	Outdoor 23-28°C (adjustable)
	Ventilate for 1h	2 hours	3 hours
Note: To obtain reasonable moisture, cold air may enter the room or sometimes prevent heating in the sun, such as excessive moisture after rain.			

Solar Ventilation fan

A Ventilation Kit can be used as an exhauster for the humid air. An exhauster is necessary in the basement or other big buildings, which can't breathe or need extra ventilation. The exhauster will be working at the same time as the solar air collector. Louver outlet with automatic close function, will keep the room heat from losing when fan turns off. Either electricity or solar energy is ok.

Max air volume: 160m³/h.



Solar Exhaust Fan OSF1

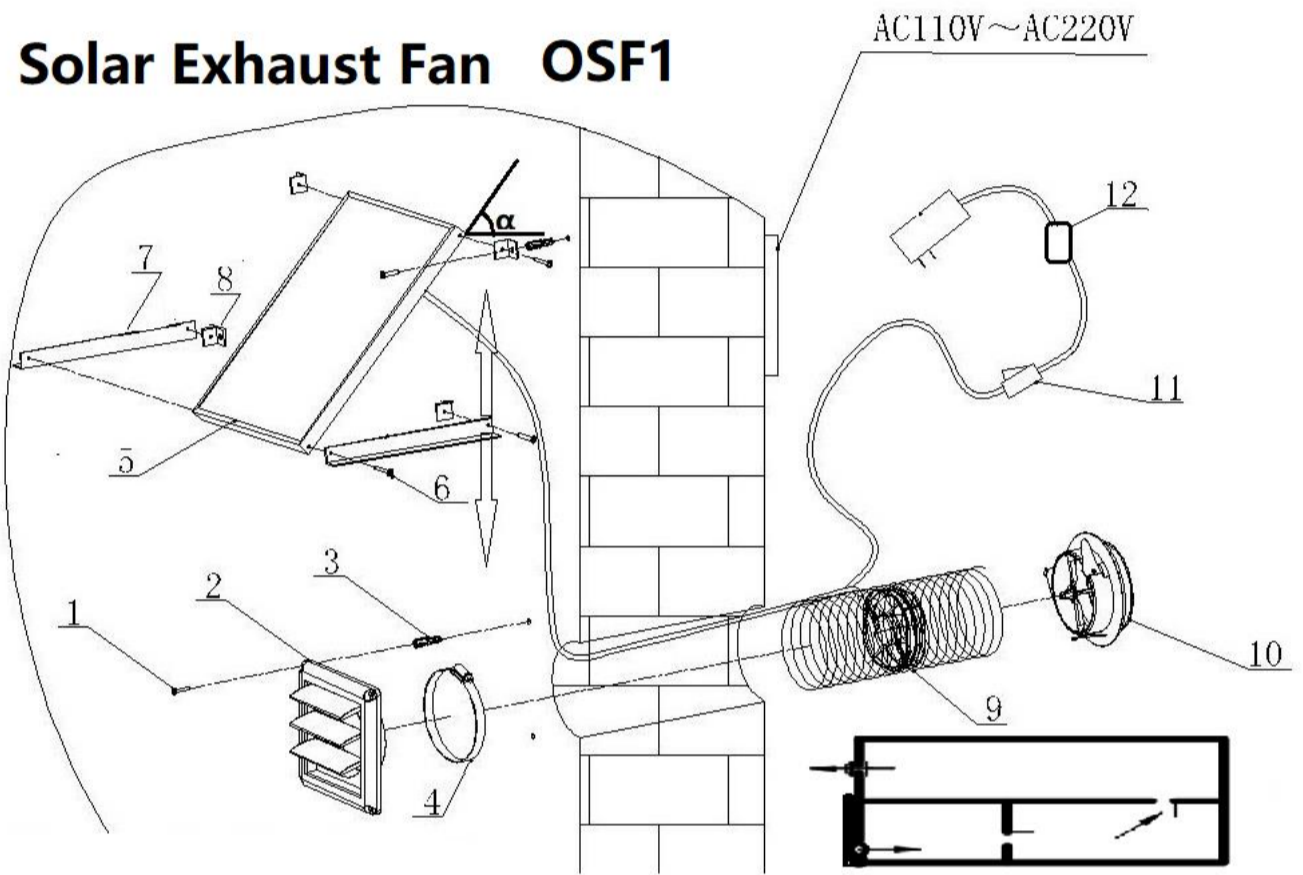

Solar ventilation fan: OSF2

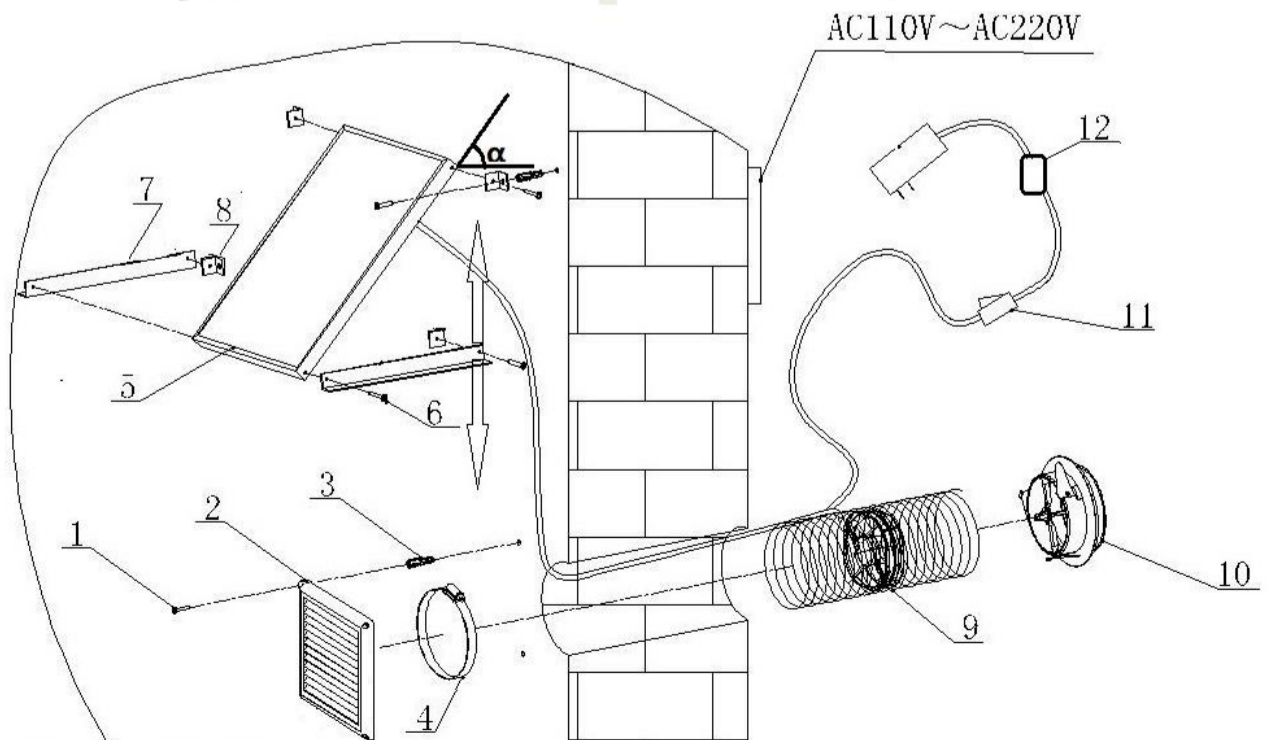
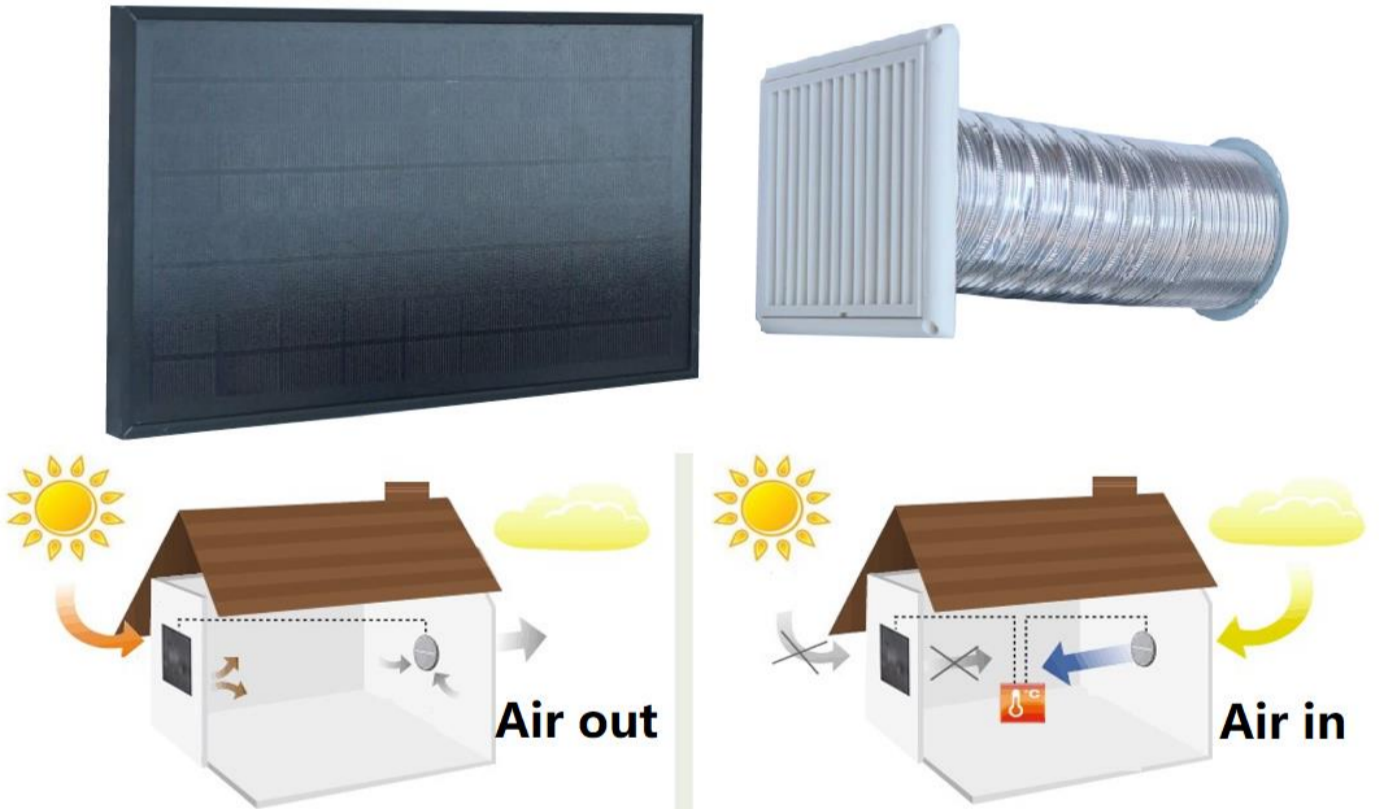

Including: 1 pc, Air outlet and Air inlet; 1 pc, Diameter 125mm Telescopic duct
1 pc, 11W solar panel; 1 pc, 125mm DC fan, Work time: 40000h.

Technical reference



Solar Panel	Width (cm)	Height(cm)	Thickness (cm)	Effective area (m ²)	Weight (kg)	Fan (mm)
OS10	52	71	6.2	0.37	6	ADDA 92*92*25
OS32	92	121	6.2	1.11	15	SUNON120*120*25
OS30	92	121	6.2	1.11	15	SUNON120*120*25
OS22	72	100	6.2	0.72	12	SUNON120*120*25
OS20	72	100	6.2	0.72	12	SUNON120*120*25
SV7	70	100	5.5	0.7	8	SUNON120*120*25

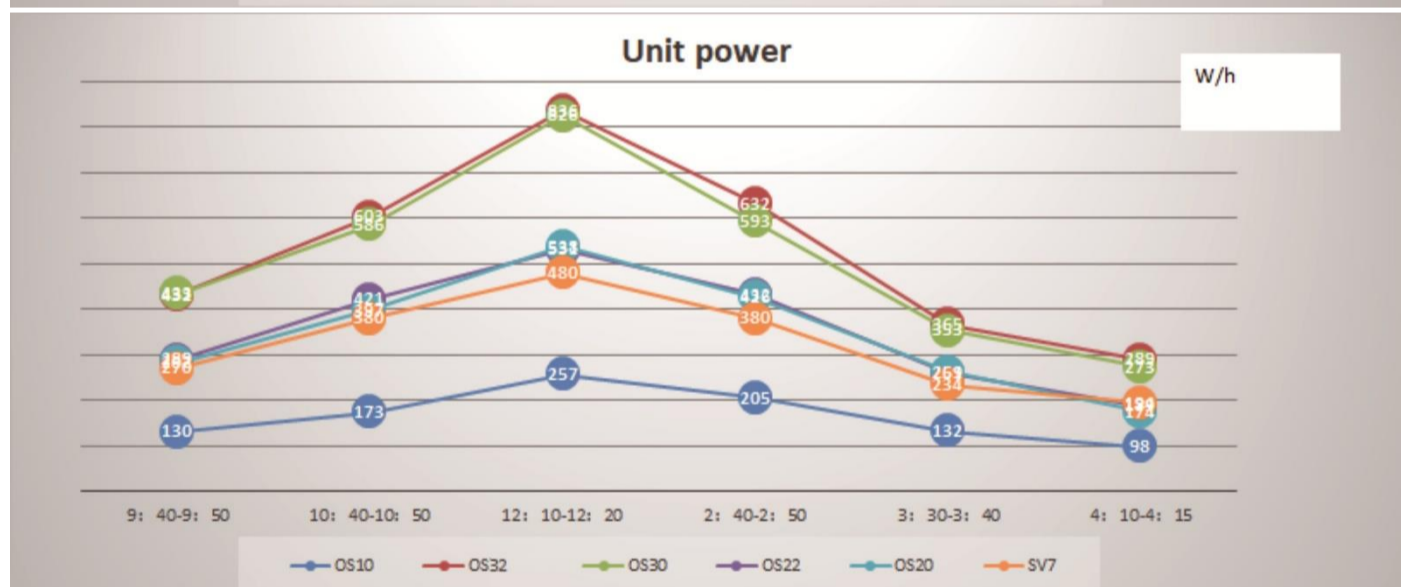
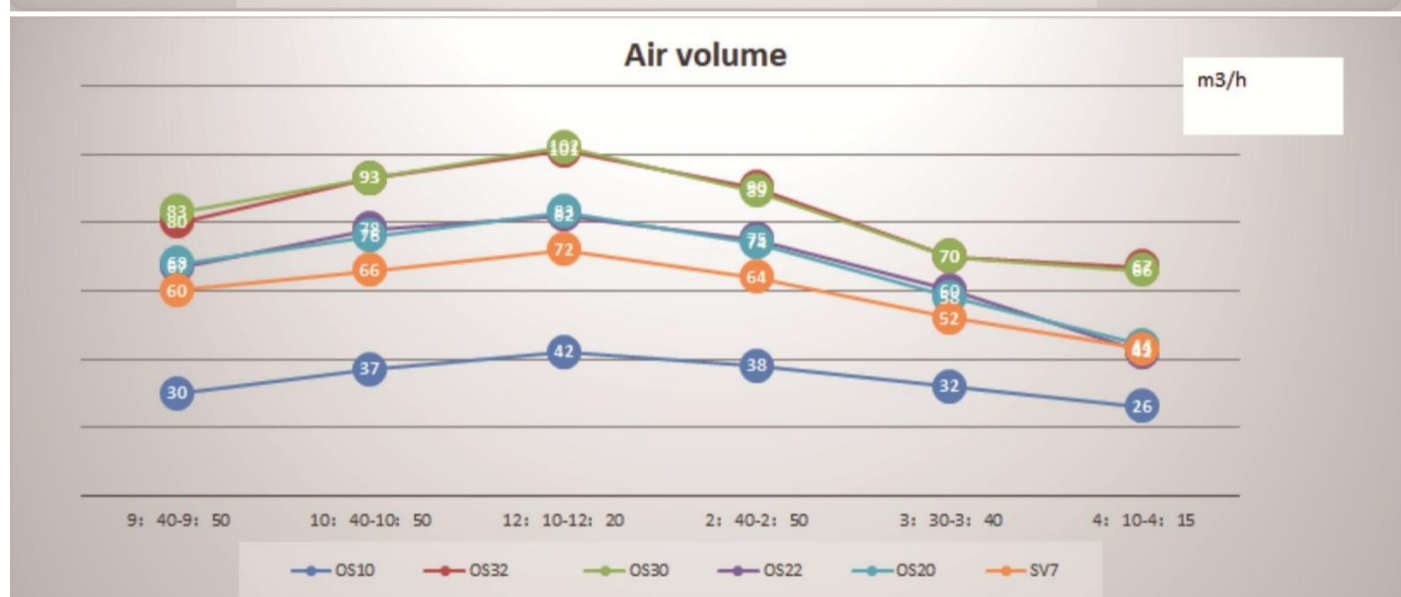
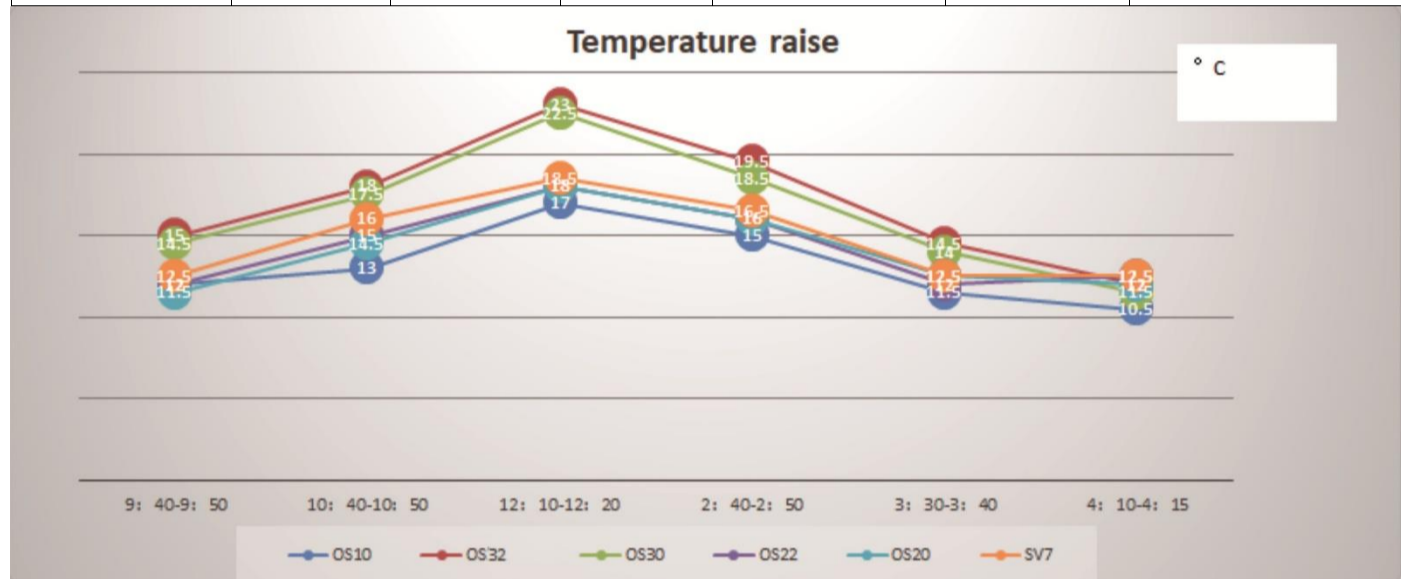

Test video for OS10 VS OS32 VS OS30 VS OS22 VS OS20 VS SV7, made in 2018:

<https://youtu.be/E1ru1enuEnQ>

Passed strict international certification, products are trustworthy. The Solar Keymark, the main quality label for solar thermal



NO.: 011-752867 L

Solar Keymark

www.solarkeymark.org

The Solar Keymark is a voluntary third-party certification mark for solar thermal products, demonstrating to end-users that a product conforms to the relevant European standards and fulfills additional requirements. The Solar Keymark was developed by the European Solar Thermal Industry Federation (ESTIF) and CEN (European Committee for Standardisation) in close co-operation with leading European test labs and with the support of the European Commission. It is widely spread across the European market and beyond. **Note: The difference between the Solar Keymark and the CE-mark The Solar Keymark is a quality label and the CE-mark just attests that the product fulfills minimum legal requirements according to specific European directives.**



TÜVRheinland®
Precisely Right.

TÜV Report No.: 50152939-001/50152941-001

The TÜV Rheinland Group is a leading provider of technical services worldwide. Founded in 1872 and headquartered in Cologne, the Group employs 19,700 people. It generates annual revenues of EUR1.92 billion.

Thermal performance testing for solar air collector; Pressure drop test; Time constant test; Visual inspection; Internal pressure test; Rupture or collapse test; Stagnation temperature; Exposure test; External thermal shock; Internal thermal shock; Rain penetration; Freeze resistance; Mechanical load; Impact

Nakoair solar air collectors always provide you with a warm and healthy home!

resistance test using steel ball; Final inspection. All above listed tests of the standard EN12975-1:2006+A1:2010 and ISO 9806:2017 were passed successfully in accordance with the criteria.



The TUV NORD GROUP brings together the brands TUV NORD, DMT, ALTER TECHNOLOGY and TUViT. Typical testing and TUV services are expanded by offers in the fields of IT, Aerospace and natural resources. More than 10,000 employees work together as an active and vibrant team, equipped with a broad horizon of knowledge and the desire to provide peak performance in their disciplines. The TUV NORD GROUP offers its services in more than 70 countries.

Advantage

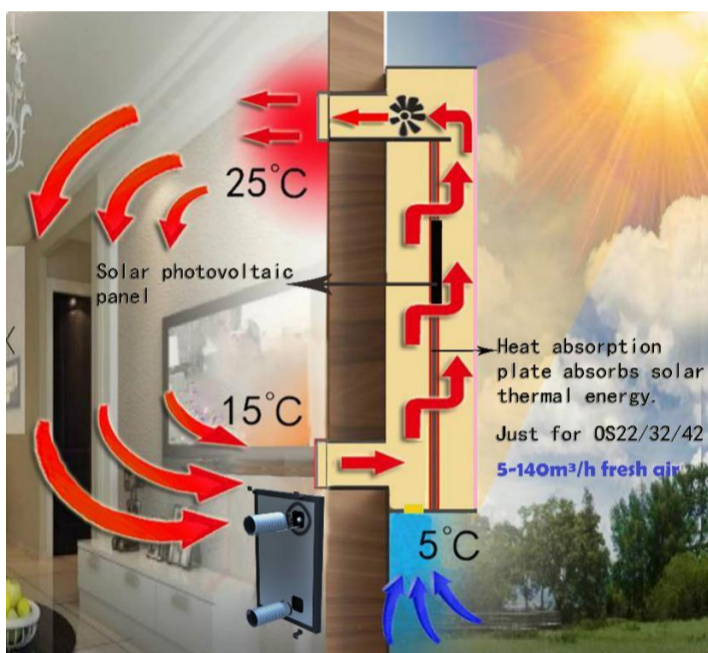
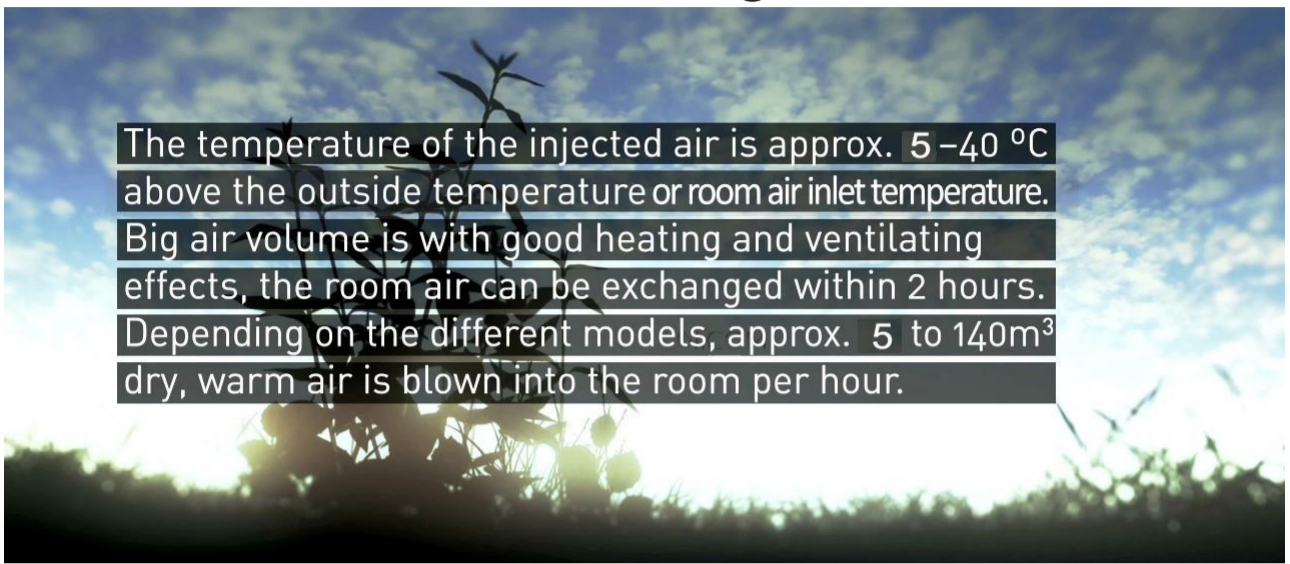

- **Heating indoor air mode**, can keep heating the room air, and keeps away from any wet or cold or smog air. When people at home or when in the winter morning, just open the room air inlet; when people out or at noon, close the room air inlet and introduce fresh air to ventilate and dehumidify.

For other models or other brands, the air speed will decrease when air pressure goes up, therefore, the efficiency of heating absorption will decrease. In case you open the window or some other gap to let air go out, but meanwhile, the heat will also be lost. So internal circulation mode is the most suitable for heating room air in the winter or cloudy day.

- **Special heating absorption board:**

Corrugated special anodic aluminum oxide, texture nano heat insulation coating, high absorption, low reflection. Solar absorbance of selective absorbing coating: 0.92; Hemisphere emittance of selective absorbing coating: 0.12.



- **Solar photovoltaic panels** are produced with well-known brand cell in high quality, high photoelectric conversion efficiency, low conversion efficiency attenuation rate, with life expectancy for 20 years. Collectors can be used to dry crops such as vegetables, fruits and grains. The service life of photovoltaic panels will not be affected even under high temperature and strong light in tropical and subtropical regions.

- Instead of hydraulic fan, **double ball fan** is adopted, with longer lifespan, low temperature resistant. SUNON from Taiwan is the most well-known fan brand in the world.



- Under sunlight, the air inside the OS collector flows along both sides of the heat absorbing plate and can absorb the heat well from the absorbing plate.

Tested in 900W / m² sunlight, when the air volume is the same, the temperature of the OS collector is

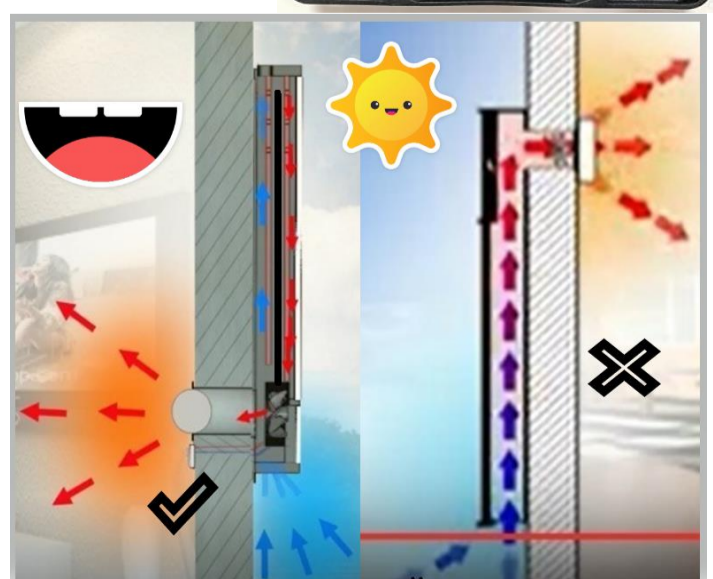

4 °C higher than the collector where air flows only from one side of the heat absorbing plate.

- Air outlet: it can be opened and closed manually or automatically, with 8mm thermal insulation cotton inside, good insulation effect. Automatically turns off when the fan is not running.



- Sealing strips are with high-quality silicone rubber: anti-UV, climate-resistance, better appearance. Frame: exclusively for open air, anti-UV texture coating, anti-UV outdoor screws.

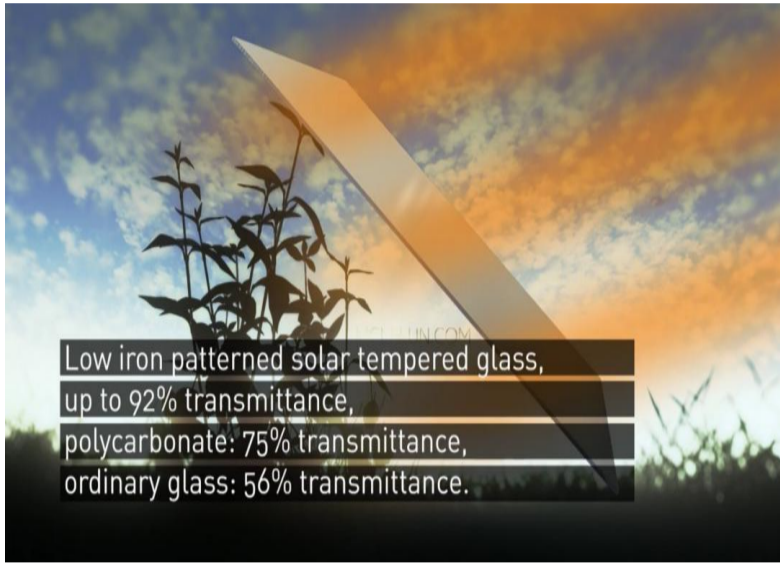

- Low iron solar tempered glass is with big intensity, high elasticity, the transmission is excellent. Lower diffuse reflection can prevent heat loss.

- Fresh air inlet of solar air heater standard PET film: stops cold air, moisture, condensation of air humidity, and back draft (When not working).

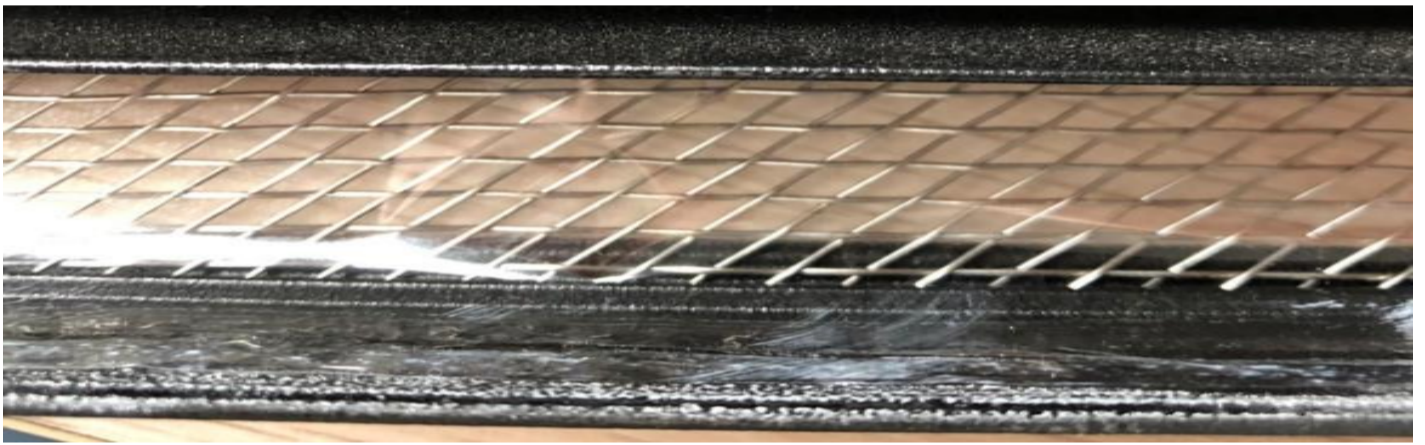

OSCAR Warranty conditions

SUNON fan life expectancy: 70000 hours; 40000 hours warranty. Thermostat, air outlet can be replaced free of charge within 2 years. The lifespan for solar pv panel is 20 years, guaranteed for 10 years. While glass and aluminum materials are with long lifespan.



Easy installation, maintenance and operation

OS32, OS40/42 can be installed in 2 different directions.

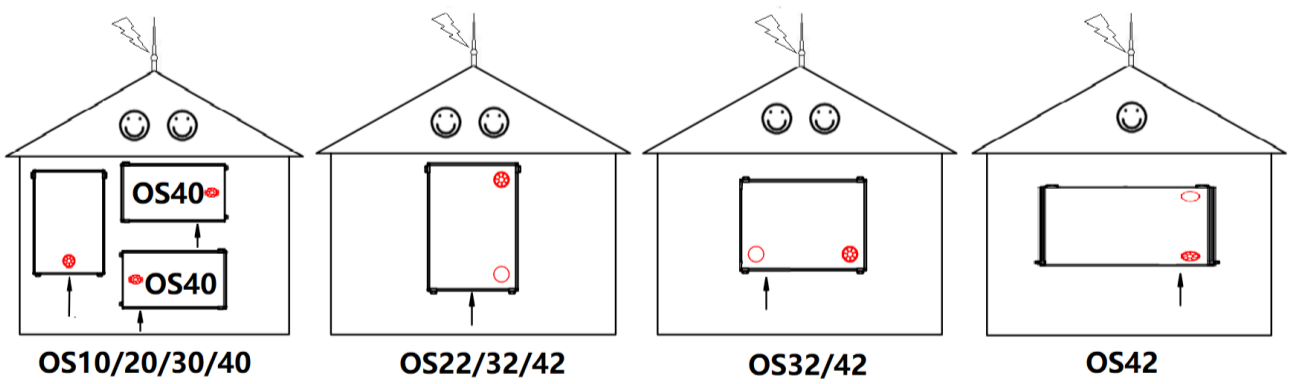

OS32+F11 H (Felt cover for horizontal installation)



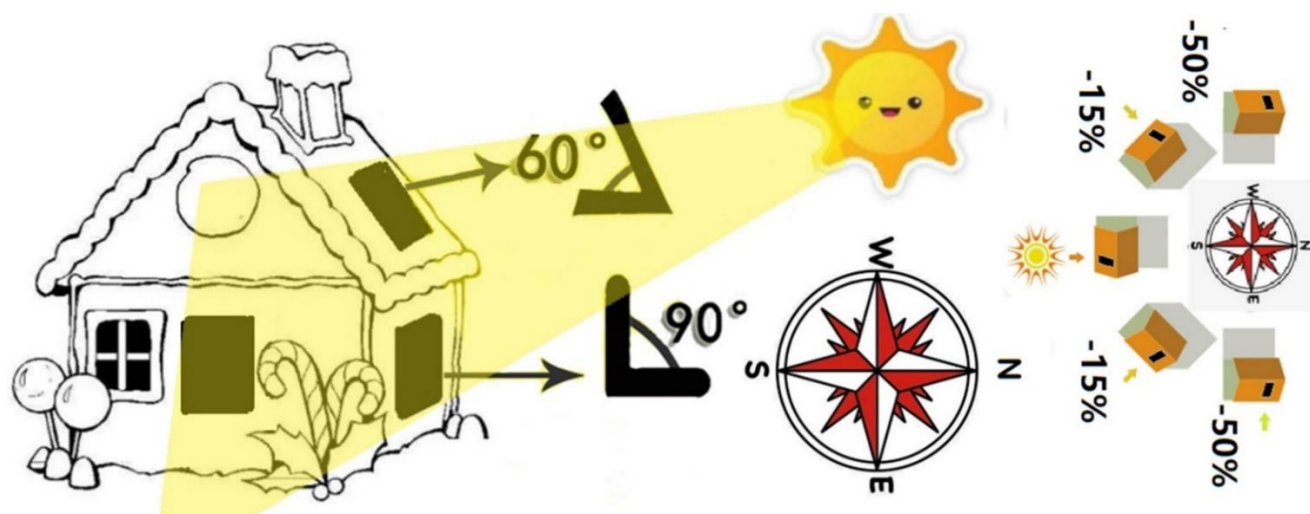

Note that by setting up two panels, e.g. one facing east-southeast and one south-southwest, you can take full advantage of the available sunshine throughout the day.

The solar air heater cannot raise the temperature of supply air or ventilate in these situations: If it's overcast, the sun isn't shining or is shining weakly, during the night, early in the morning or late at night and when the panel is covered by snow or ice or during rain.

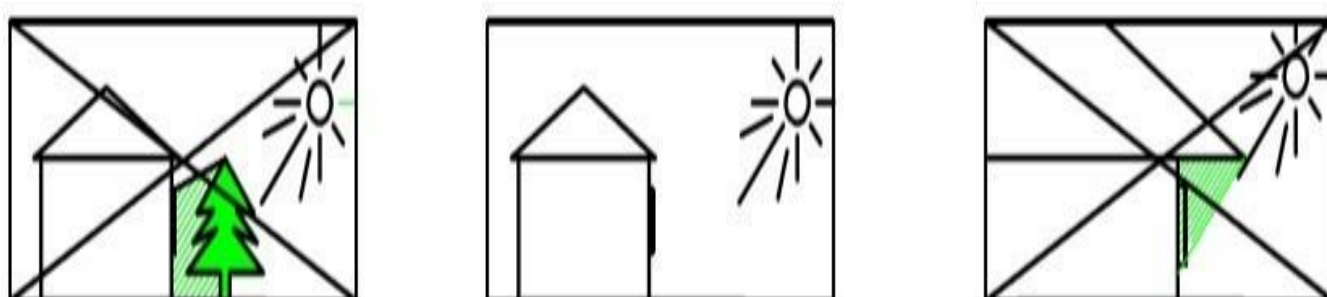

Can be installed on the wall or roof without the help of electrician/ construction worker. Small area, light weight. Installing your solar panel is so easy that you can do it yourselves. Product includes thermostat and all the necessary accessories for installation, such as screws, fixing clips, air ducts, air outlets, manuals, etc. Please distinguish wooden house and brick wall, so the correct electric drill is adopted. You can substitute the spare parts except solar pv panels all by yourself within 30 minutes, with easy tools like scissors, tape, screwdriver, etc.

Wooden house tools:



The new invisible fixed buckle can be selected, and the fixed buckle cannot be seen after installation.

If you want to increase the heating efficiency, please increase the wind speed, the heat loss will be reduced. Please turn down the air outlet, if you need air going to the room with higher temperature; Or feel too noisy.

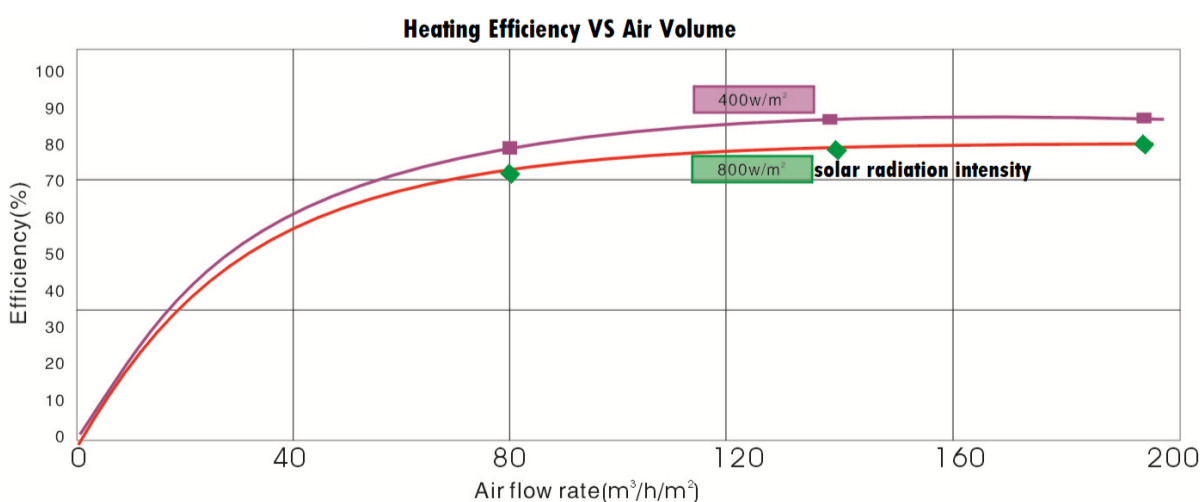

Tips

- Glass panel is with 20 years life span, which is much longer than polycarbonate panels, which are only 10 years, and after sunlight irradiation, it becomes yellow and solar transmittance goes extremely lower.



- The felt gap used in the collector is easy to corrupt and fade after being exposed to open air for long term. If there is a lot of dust in the air, easy to be blocked. Felt gap is large, PM2.5 also cannot be filtered.
- The backside is installed on the wall without interval. Wall with good insulation prevent heat waste. There are several bugs and bias in Delta test. The samples are put against a ladder, without insulation of wall, so the testing temperature is lower than Oscar's actual performance. But some other brands bring in air at the backside, so the airflow can be bigger if there is no wall at the backside, and testing temperature would not decrease.



Company introduction

Oscar Science & Technology Co., Ltd. is a professional manufacturer of solar air collector/ heater, solar ventilator etc.

We have got ISO9001 2015 certificate from German TUV NORD CERT since 2018, No.:44 100 1888 0001; European Solar Keymark certification (ISO9806), No.:011-7S2867 L; TÜV Rheinland test Report No.: 50152941-001 &50152939-001.



A developing and testing lab is well established to test air volume, temperature difference of different models in different conditions, also insulation, UV-resistance, climate-resistance, water-proof to various materials such as coating and silicone.

We have innovatively adopted high-tech material like low iron ultra-pure glass and special texture nano insulation coating etc, and are dedicated to sustainable development and innovations, to ensure good quality and high performance.

Oscar solar air heaters are sold to many countries like UK, Denmark, Germany, Czech, Australia, New Zealand, Canada, America etc. In the past years, with continuous improvement and innovation, and focus on R&D, quality control, the Oscar solar air heater has won a good reputation due to its high performance and competitive price.

Users' comment

“After using OS22 air heater, we have cut our family heating bill by as much as 40%” ----Timur Mukhtarov, Russia

“The performance is unexpected. I actually didn't expect that much heating effect with such low price! When I put my hand at the air outlet, I can feel the heat and airflow pretty much! Thanks to OSCAR!” ----Alan Marutti, Italy

“We have saved 430 gallons last year with Oscar solar heater, which cut 35% of our heating bills. It's really great!” ----Tracey Ahlborn, USA

User A: This product is an excellent idea - who wouldn't want to heat their space for free using only the sun's energy? Garden rooms, holiday cabins, storage rooms, sheds, caravans, houseboats, etc. In other words, a space that is not in constant use, can be left unattended for long periods of time, and is at risk of damp or deteriorating air caused by lack of use.

It works by sitting on the outside wall and using the energy of direct sunlight to heat the air behind a pane of glass. This warm air is then blown through a pipe into the interior of your home

Nakoair solar air collectors always provide you with a warm and healthy home!

using an electric fan that is also available powered by a small photovoltaic system is mounted behind the glass pane. The entire process is controlled by a box on the inner wall that measures the relative temperature and indoor humidity. Brilliant!

In the right circumstances the whole concept is excellent and I've had fun experimenting with the unit. I wouldn't want them fitted all over my house feeding to all the rooms but they would for the above cottages, garden structures or sheds they are ideal and a perfect way to keep these spaces moisture free and much fresher and healthier. If my grandma had one of these fitted in her caravan her holiday guests would not have been exposed to the stale air and mold carpets and curtains on arrival. Ah who have favoured childhood memories!

It is important to know that care should be taken when placing these units and not all situations will be suitable. If your room is north facing and the structure is surrounded by trees this will not work. It needs direct sunlight and more the better, and that means an open, south-facing orientation. So consider the daily shade path of the trees.

User B: The materials and workmanship in general are of good quality, I like it.

I put it in a shed where I keep the garden tools because it always has moisture and things rust.

It's very convenient for me because I don't have electricity there.

It's important to have a sunny wall for the solar panel to work, that's the most important thing, otherwise it won't work or be ineffective.

It's been a week since I put it on and I'm watching it and it works, you can tell the fan turns on and off depending on the time of day.

The truth is that the room was very wet but if I realize that it removed the cold and damp that I have always noticed. I've had the door and a wet sheet cupboard with water droplets before, and now I don't notice it anymore.

The truth is that I liked it and that it solves ventilation and dehumidification problems. I don't think it will have enough power to heat a large room to a comfortable temperature, but it will safely dissipate moisture and cold. Perhaps a larger model, should it also heat the room when the sun is good, because under the sun the outside air temperature could have risen by more than 10 °C.

User C: The first task of this solar air heater is to use the solar panels to heat the air that is "blown" into the room by the small fan.

The part is suitable for rooms that have no heating but need ventilation, so that no mold or similar forms develop.

I use it for the garage, I don't have heating there because I didn't think it was necessary.

Nevertheless, ventilation should be provided during the day in winter, preferably with slightly warmer air, to prevent frost.

I put it in front of the window, as soon as the sun starts shining, the Nakoair Solar air heater starts blowing air into the garage.

So if you have an apartment, garage, basement or a room whose window side gets a few rays of sunshine, you can confidently use this solar air heater.

However, if there are no sunbeams from the side, then this is of no use.

I am very satisfied because it fits very well, both in size and sun exposure.



No.44 100 1888 0001



011-752867 L

Solar Keymark

www.solarkeymark.org



TÜVRheinland®
Precisely Right.

TÜV Report No.: 50152939-001/50152941-001

OSCAR solar air collectors always provide you with a warm and healthy home!

Avoid humidity Avoid stale smell Avoid mould and fungus

Contact us

Oscar Science & Technology Co., Ltd.

Email: info@nakoair.net

Web: www.nakoair.net

Address: Albert-Schweitzer-Str.1 Tor 20 55459 Grolsheim Germany



Friendship Links:

Nakoair solar air collectors always provide you with a warm and healthy home!

<https://www.solarair.cz/>
<https://solarniventilace.cz/cz/>

<https://solarventi.de/>
<https://solarventi.dk/>



Nakoair solar air collectors always provide you with a warm and healthy home!