

WAHSON

Mesh Back Stackable Chair, Set of 5

WS-1108-5PCS

User's Manual for 1 piece

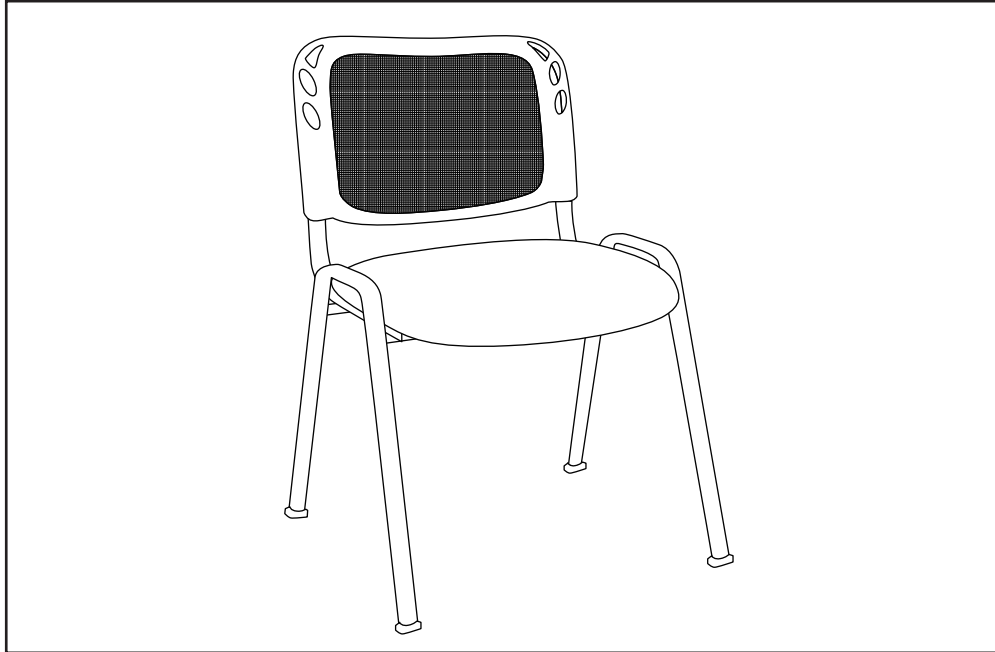

Contents

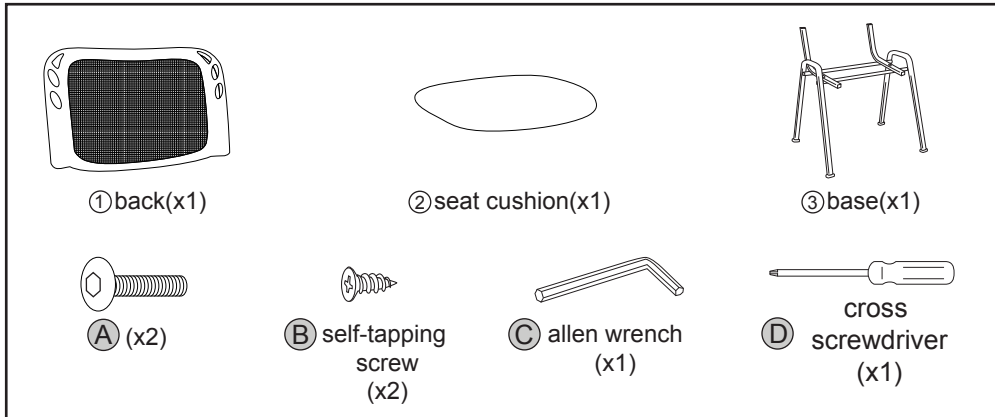

Assembly Instructions

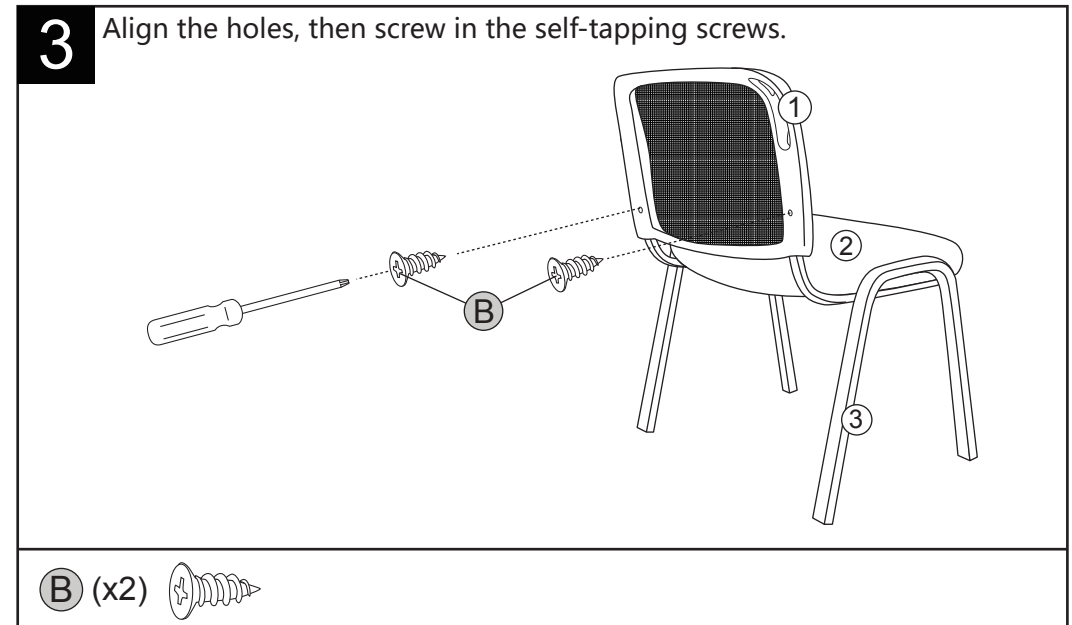
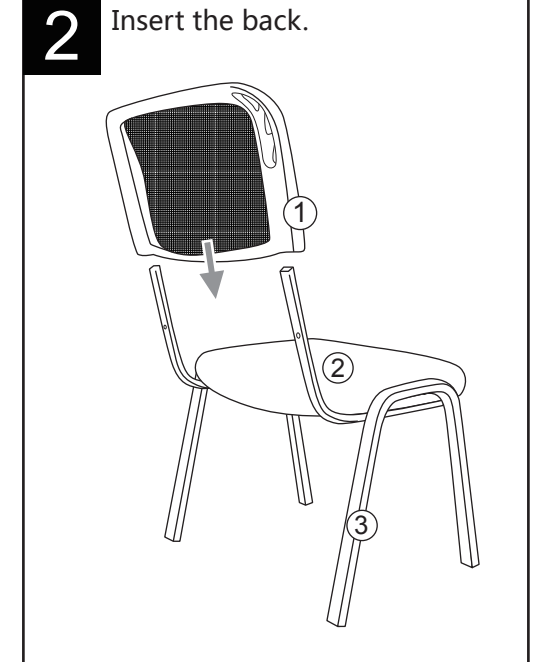
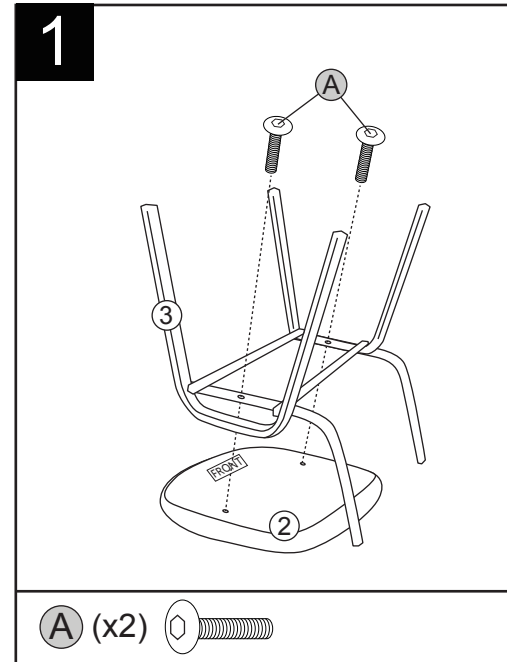

Safety and Compliance

- Use care when handling.
- Please read the instructions completely before assembly.
- Remove all parts from the carton and ensure all parts are included prior to assembly.
- Assemble the chair on the carton or carpet to prevent scratching the chair.
- Be careful not to cross-thread screws.
- Do not use power tools

Cleaning

- To clean, wipe with a soft, slightly moist cloth.
- Never use corrosive detergents, wire brushes, abrasive scourers, metal or sharp utensils to clean the product.

Maintenance

- Check the components regularly to make sure all screws are tightened.

Feedback

Love it? Hate it?

Let us know with a customer review.

Wahson is committed to delivering customer-driven products that live up to your high standards. We encourage you to write a review sharing your experiences with the product.

Please visit: [amazon.com/review/review-your-purchases#](https://www.amazon.com/review/review-your-purchases#)



For further services:
care@wahsonchair.com

Warranty

The Wahson Company promises to repair or replace any Wahson product or component that is found to be defective in material or workmanship within two (2) years from the date of original purchase so long as you, the original purchaser, still owns it. This is your sole and exclusive remedy. This warranty is subject to the provisions below. It applies to product manufactured after January 1, 2017.

Limitations:

- Upholstery on chairs is warranted for one year from date of purchase.
- Damage caused by the carrier in-transit is handled under separate terms.

Exclusions:

This warranty does not apply and no other warranty applies to:

- Normal wear and tear, which are to be expected over the course of ownership.
- Modifications or attachments to the product that are not approved by The Wahson Company.
- Products that were not installed, used, or maintained in accordance with product instructions and warnings.
- Products used for rental purposes.

Seating Usage:

Normal commercial use for seating is identified as the equivalent of a single shift, forty- (40) hour workweek.

To the extent that a seating product is used in a manner exceeding this, the applicable warranty period will be reduced in a pro-rata manner.

A word about color variations, fabrics and finishes:

The Wahson Company does not warrant the color-fastness or matching of colors, grains, or textures of covering materials.

To obtain service under this warranty:

please take the following steps:

1. Contact us by mailing to care@wahsonchair.com. Be prepared to provide the order number of the product in question.
2. The Wahson Company customer service representative will gather all pertinent information regarding the claim. (Please allow a reasonable amount of time for inspection and review.)
3. If The Wahson Company affirms that the product in question is eligible under the conditions of the warranty as stated above, the customer service representative or another representative of the Company will determine whether to provide replacement parts, authorize repairs, or replace the product.

wahsonchair.com