

## How to Install

### Important

**Note: All unfitted glass is fragile**

To prevent product failures ensure that:

- All fitting steps are correctly completed
- A space of a least 2mm is left between the product and all surfaces.
- Only use neutral cure silicone adhesive (BS EN ISO 11600). Silicone adhesive purchased from Royston Glass is a neutral cure product. Other silicones, adhesives and mirror adhesives may over time degrade the finish of the glass installation and negate relevant product guarantees.

### Tools Required

- Tape measure
- Sealant gun
- Silicone adhesive - only use low modular neutral cure silicone (BS EN ISO 11600)

### Checklist

- Do you have everything you need to start the job?
- Check that the splash back fits.
- Is it the right colour?
- Ensure that your worktop is fitted securely.
- Check that your worktop is level.
- Clear all dust from the worktop.
- Ensure that your hob is fitted in accordance with the manufacturer's instructions and that the clearance between the hob and splashback complies with the appliance manufacturer's instructions.
- Make sure that your extractor is securely fitted in accordance with the manufacturer's instructions.

### Installation

- **Safe Glass Handling** - remember all glass must be handled with care. We recommend that eye protection and suitable gloves are worn. Drilling and cutting should not be undertaken.
- Ensure surface is non porous, dry and dust free.
- Hold up the back of the splashback to the worktop/wall to check fit. Use spacers to achieve a good fit.
- Take the splashback away making sure to keep all corners safe from hard surfaces. **Apply silicone adhesive 10mm in from the edge of the splashback the whole way around the perimeter of the splashback on the painted side of the glass.**
- Place the bottom edge of the splashback on the spacers, then push the splashback to the wall and apply firm pressure evenly over the whole surface area.
- **Remember glass cannot be cut following the toughening process therefore any plug sockets etc must be requested at the initial ordering stage.**

### After Care

- Do not use abrasive cleaners. For best results use hot water with mild soap detergent.

### Do Not

- Fit the splashback directly onto a hob.
- Place the splashback on its edge on any hard surface during the fitting process.
- Use the product until the silicone has cured (follow the manufacturer's instructions).



**1** First check the dimensions.

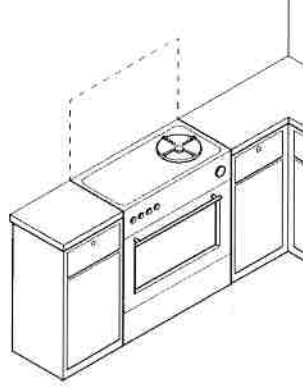

**2** Ensure the surface being fixed to is flat, nonporous, dry and dust-free.

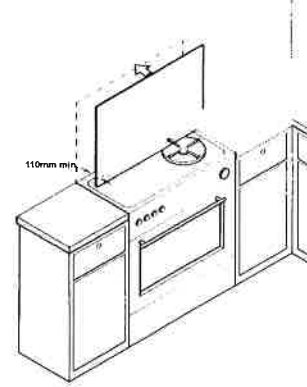

**3** Hold up the back of the splashback to the worktop/wall to check fit. Use spacers to achieve a good fit.

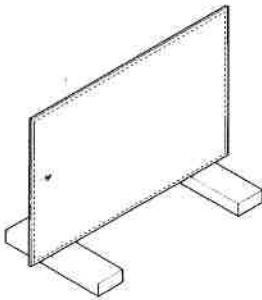

**4** Take the splashback away making sure to keep all corners safe from hard surfaces. Apply silicone adhesive to the perimeter of the glass 10mm in from each edge. Sit the splashback on top of the spacers.

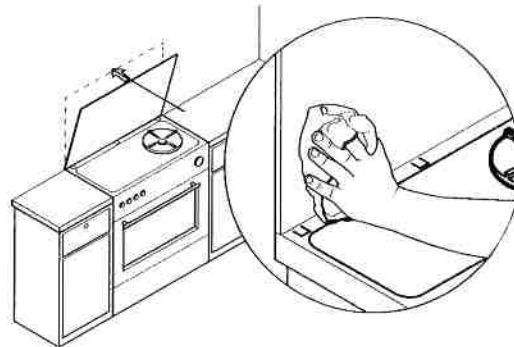

**5** Place the bottom edge of the splashback on the spacers, then push the splashback to the wall and apply firm pressure evenly over the whole surface area.

Ensure that a 2mm space is left. Finally remove spacers.

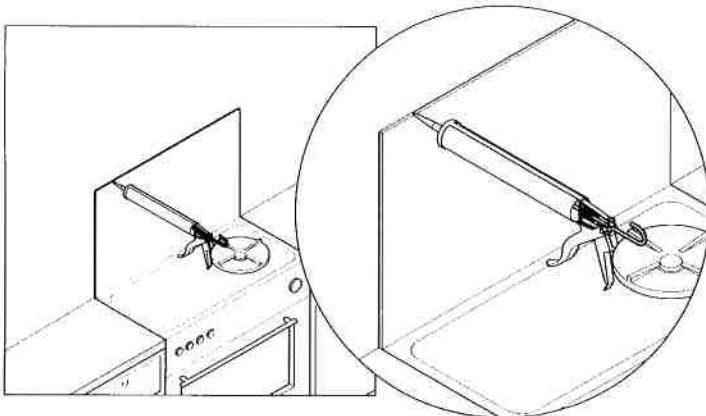

**6** Seal the edges of the splashback with a bead of silicone sealant not less than 2.5mm in thickness

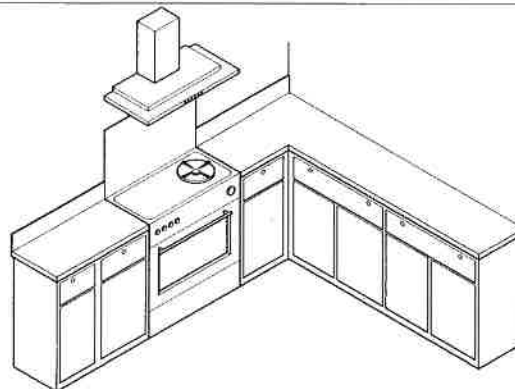
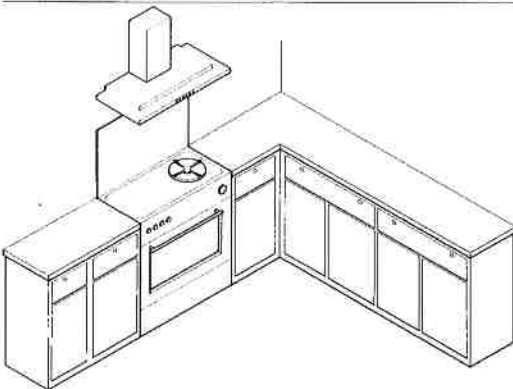

**7** Complete the surrounding wall covering.