

u h u r u



Uhuru Design is the Brooklyn-based New American furniture design firm specializing in bespoke residential and high-end commercial furniture. Founded in 2004 by Rhode Island School of Design graduates Jason Horvath and Bill Hilgendorf, Uhuru gained attention for its sustainable approach, utilizing reclaimed and found materials through a narrative design process. This design approach generated collections currently in the Smithsonian and Brooklyn Museums, positioning Uhuru at the forefront of New American Design and popularizing the “Brooklyn” aesthetic. Uhuru scaled from bespoke residential to mass office furniture, evolving with the growing New York and West Coast startup scenes. Uhuru focuses on delivering accessible New American Design to mission-driven clients across residential, hospitality, fast casual, office, co-working, architecture, and interior design landscapes.



MINIM OFFICE
STATIONARY WORKSTATIONS



STATIONARY WORKSTATIONS

We believe that a commitment to craft, style, and authenticity is just as important in the workplace as it is in the home. Our MINIM workstations are built upon customizable elements, such as base styles, table dimensions, and curated finishes that combine to create numerous possibilities and to meet the demands of any team. Stationary workstations are the foundation of our fixed height desking and benching system, trusted by leading brands and interior designers.



SPLIT BASE



BROAD BASE



SQUARE BASE

LEG PROFILES

Surface
D 29.5" | 750 mm

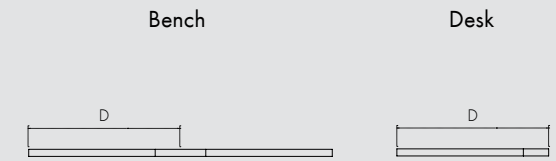

Split
BW 38" | 967mm
H 29.5" | 750mm
DW 23.5" | 597mm
H 29.5" | 750mm

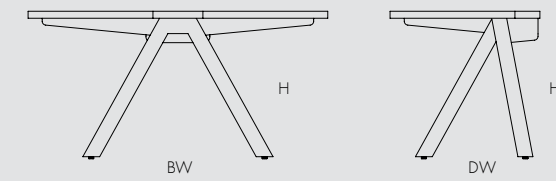

Broad
BW 31.5" | 799mm
H 29.5" | 750mm
DW 25" | 637mm
H 29" | 750mm

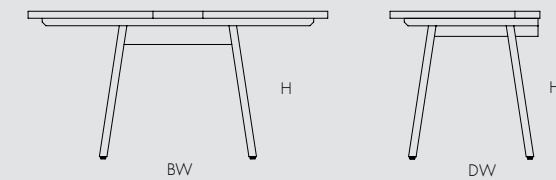

Square
BW 59.5" | 1511mm
H 29.5" | 750mm
DW 29" | 743mm
H 29.5" | 750mm

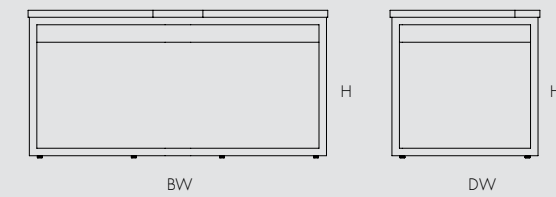



CONFIGURATIONS

Standard Bench

W 47.25" | 1200mm
 W 59" | 1500mm
 W 71" | 1800mm

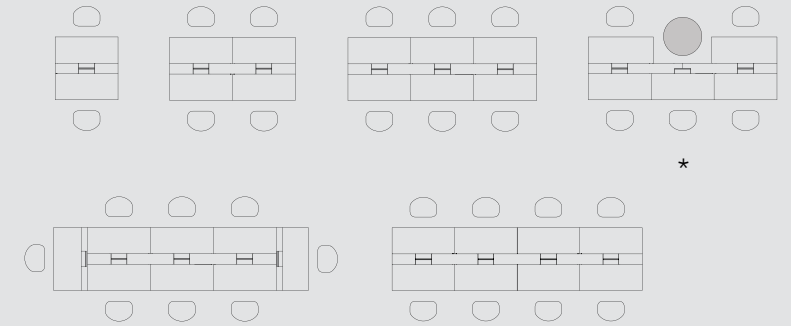

*Surface can be removed to adapt to your space.

Standard Desk

W 47.25" | 1200mm
 W 59" | 1500mm
 W 71" | 1800mm

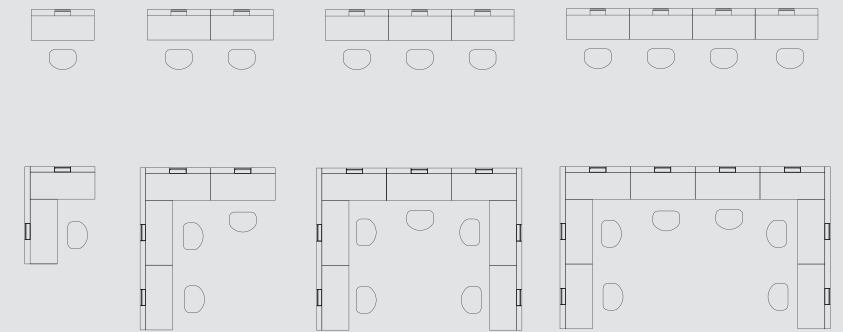



POWER + DATA

MINIM OFFICE comes equipped with two removable panels on each intermediate leg to accommodate wires from power and data floor cores. Designed to direct and conceal wires into the workstations, the center channel is designated for data and the outer channels for power. Once fed through the leg, the wires can navigate through the troughs for easy installation.

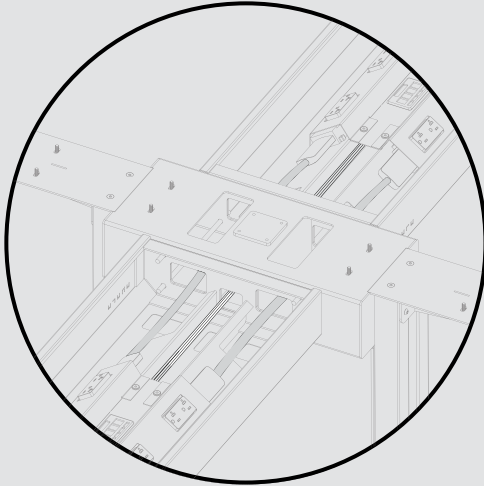
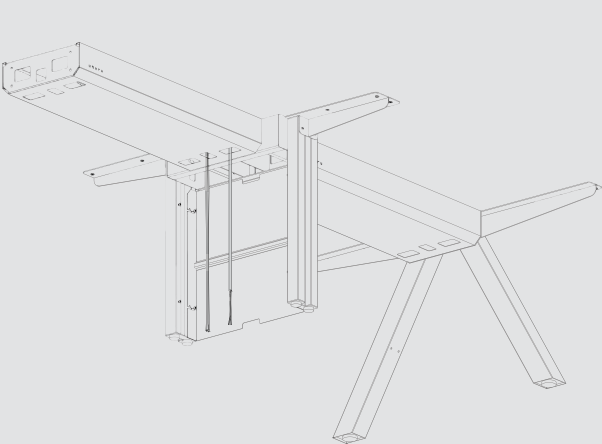

If running electrical from a wall, our system is equipped with three holes at the bottom of each trough; the center for data and the outer two holes for power. Wires can then be fed under the leg and up through the trough cut-outs for easy installation.

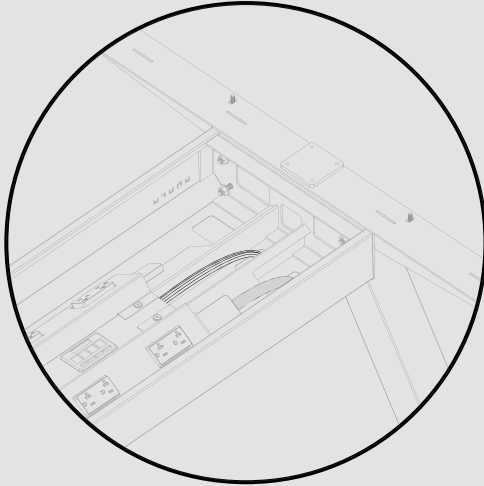
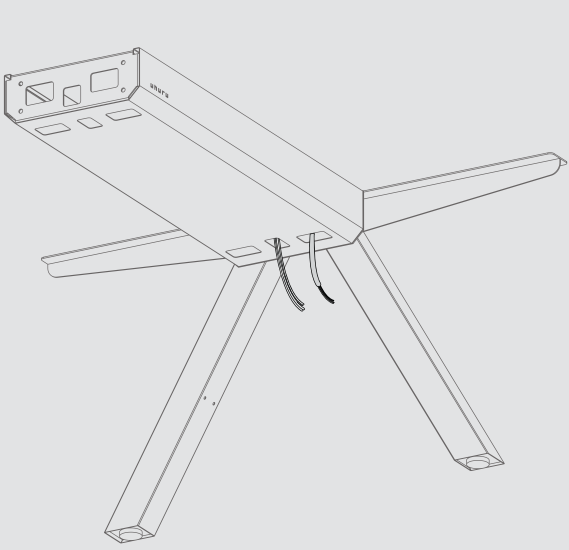



FINISHES

Top



1

2

Laminate

- 1 White
- 2 Black



3

4

5

Wood

- 3 Natural Oak
- 4 White Washed Ash
- 5 Walnut

Base

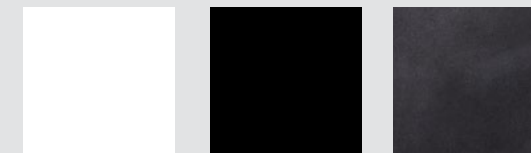

1

2

3

Metal

- 1 White
- 2 Black
- 3 Uhuru Black

Storage



1

2

Lacquer

- 1 White
- 2 Black

Divider

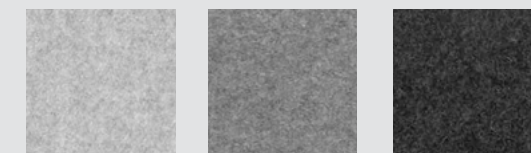

1

2

3

Felt

- 1 Stone
- 2 Grey
- 3 Charcoal

ACCESSORIES

Dividers

Felt Divider and Post

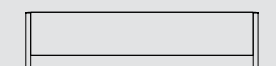

Accessories

Side-to-Side Divider

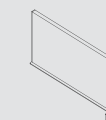

Low Pedestal Cushion

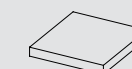

Modesty Panel

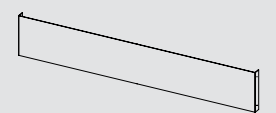

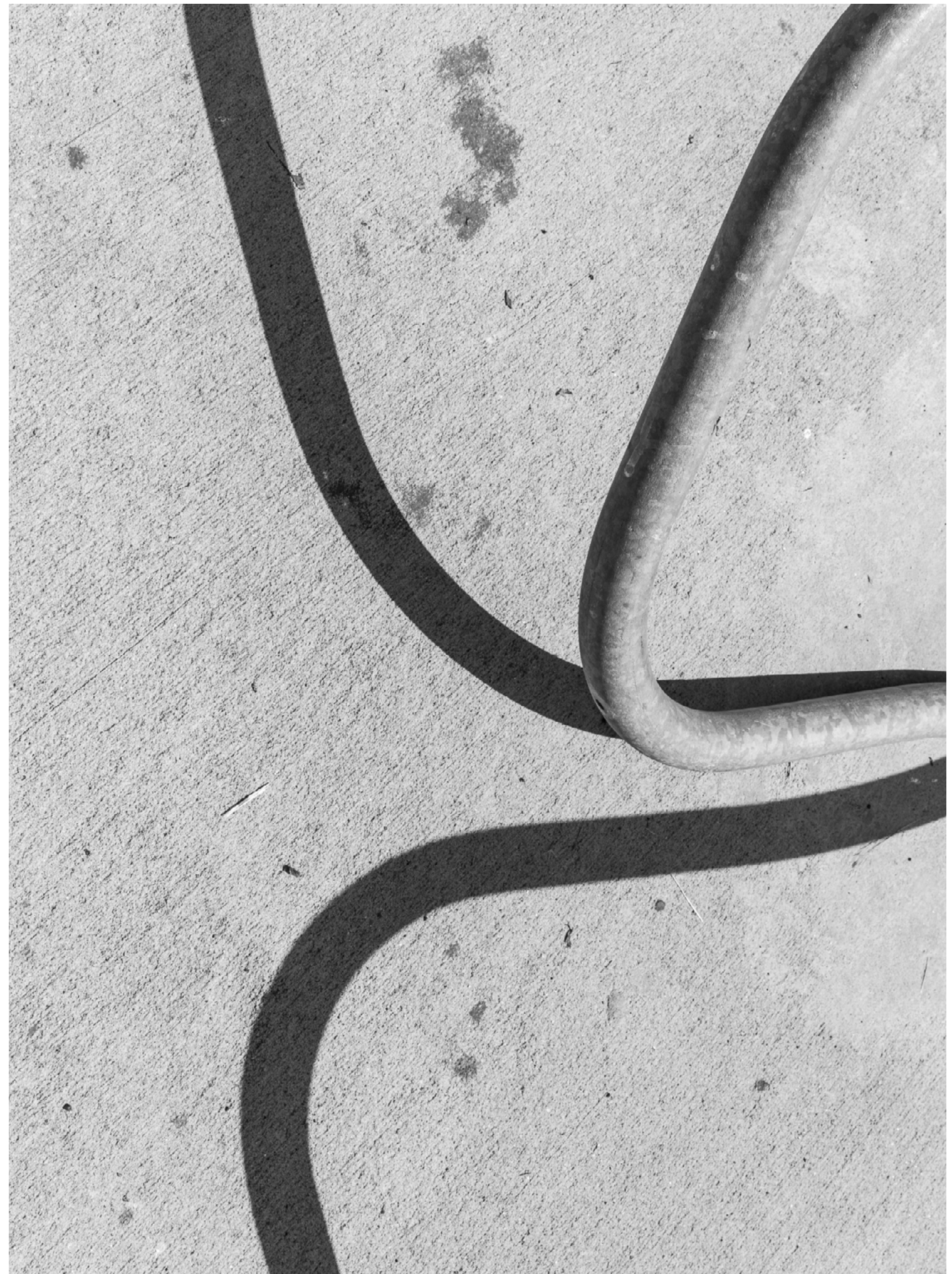



MINIM RISE
SIT | STAND WORKSTATIONS



SIT | STAND WORKSTATIONS

How do you design a sit stand workstation with timeless appeal? We tackled this concept with carefully considered proportions and authentic materials that define our collections. MINIM RISE, our sit stand system, incorporates an industry leading electronic lift system into its sturdy steel base, seamlessly concealed beneath a variety of work surface options. RISE's lasting design aesthetic and unique ability to integrate both fixed height and sit stand functionality into one system is what distinguishes it from the rest. RISE has the unique ability to switch out lifters so your team can decide to incorporate sit stand capabilities at a later time. The RISE system is available in 3 desk widths, configurable up to 12 desks per cluster, and customizable in standard wood and metal finishes.



SIZES

MINIM RISE Bench

W 47.25" | 1200mm
W 59" | 1500mm
W 71" | 1800mm

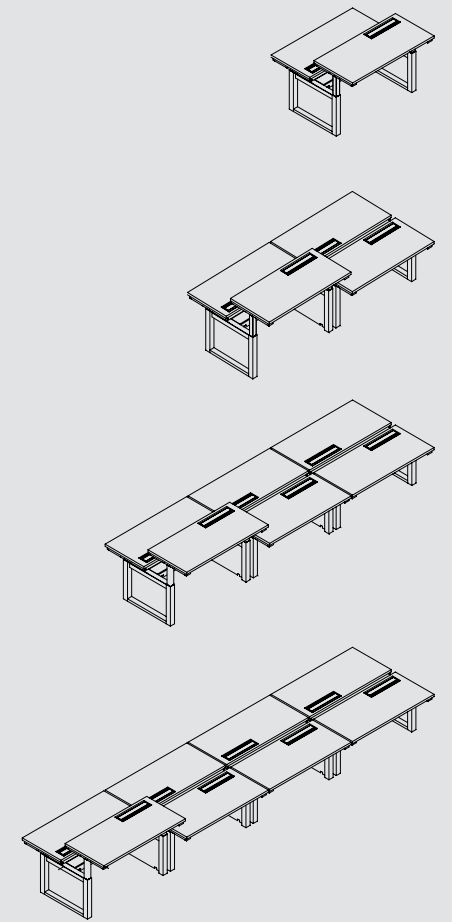

MINIM RISE Desk

W 47.25" | 1200mm
W 59" | 1500mm
W 71" | 1800mm

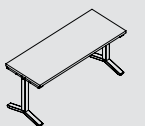



PRIVATE OFFICE



PRIVATE OFFICE

Uhuru's private office configurations are optimized for individual use in enclosed workspaces. Each office can be customized with any combination of workstation, return, and storage options to fit the floor plan. Styled after our Signature Collection, our private office options create an oasis within the workplace.





PRIVATE OFFICE | OPTIONS



DESK + FULL KINKED PANEL + RETURN + OVERHEAD



DESK + SINGLE LOW+ DOUBLE LOW



DESK + MODESTY PANEL + DOUBLE LOW WITH RETURN TOP



TOTEM STORAGE



TOTEM STORAGE

Inspired by minimalist sculpture and modular forms, our Totem Rolling Pedestals are designed to tuck underneath workstations and sit on hidden wheels. Its built-in surface tray keeps supplies handy, while the top drawer is great for small personal items. The bottom drawer is compatible with letter and legal filing, and is spacious enough to stow backpacks or other personal items. The Totem Rolling Pedestal comes in a range of sizes that make the collection an ideal and sculptural choice for deskside storage.

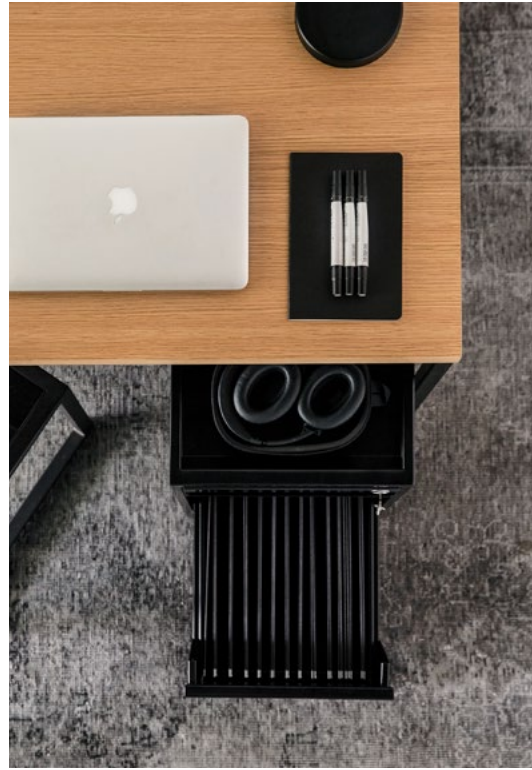

TOTEM SLIM IN BLACK



TOTEM SLIM IN WHITE



TOTEM SLIM ROLLING PEDESTAL





TOTEM SLIM IN ROSE + TOTEM STANDARD IN OCEAN

TOTEM STORAGE OPTIONS

Totem Standard Rolling Pedestal

L 19.5" D 15.75" H 20.5"
L 495mm D 400mm H 521mm

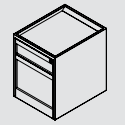

MOBILE BOX/FILE

Totem Slim Rolling Pedestal

L 19.5" D 12.75" H 24"
L 495mm D 325mm H 607mm

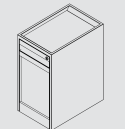

MOBILE BOX/FILE

* We offer Totem Storage in customized dimensions that contribute toward satisfying Feature #89.3 Adaptable Spaces under the WELL Building Standard®

FINISHES

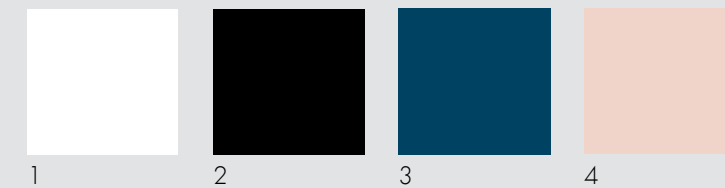

Powdercoated Steel

- 1 White
- 2 Black
- 3 Ocean
- 4 Rose



MINIM STORAGE



MINIM STORAGE

MINIM storage has a multi-dimensional selection of options, curated for personal, team, and shared storage. Mix and match to organize a storage wall in a private office, combine units to create accessible storage in an open plan workspace, or showcase greenery desk-side with planter extensions. MINIM Storage is designed to incorporate seamlessly into our desk and benching systems or stand on its own.





LATERAL FILE, 3-HIGH 01



LATERAL FILE, 3-HIGH 02



DOUBLE LATERAL FILE, 2-HIGH 02



DOUBLE LATERAL FILE, 2-HIGH 0

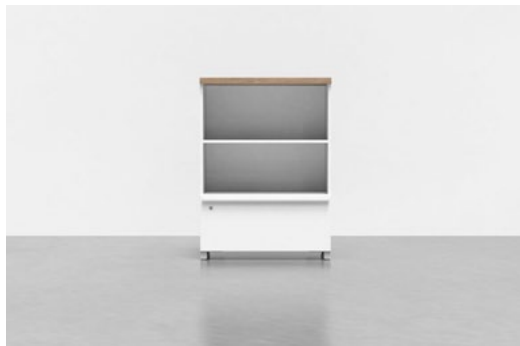

LATERAL FILE, 3-HIGH 03

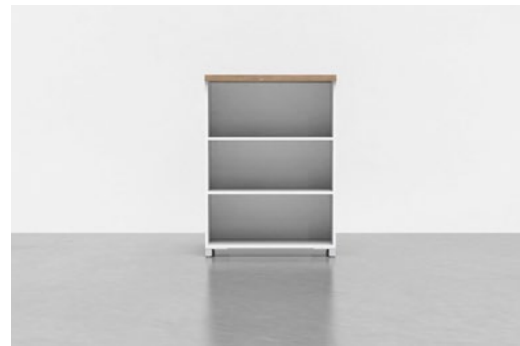

LATERAL FILE, 3-HIGH 04



ROLLING PEDESTAL



LOW PEDESTAL



LATERAL FILE, 2-HIGH 01



LATERAL FILE, 2-HIGH 02

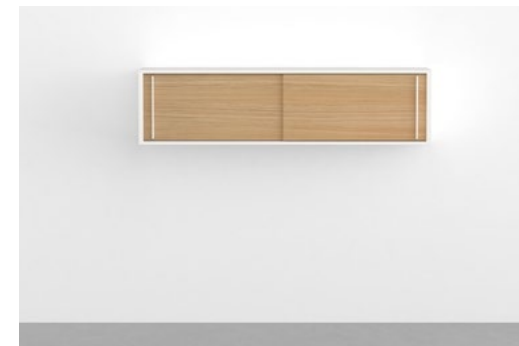

OVERHEAD CABINET



EXTENSION CABINET 01

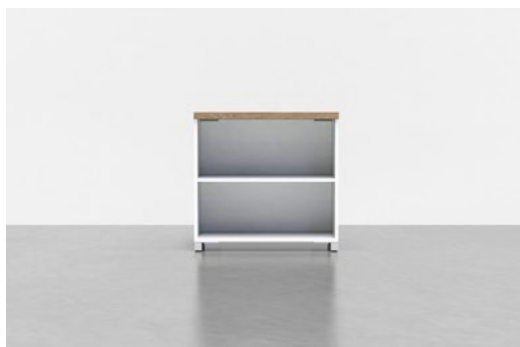

LATERAL FILE, 2-HIGH 03



DOUBLE LATERAL FILE, 2-HIGH 01

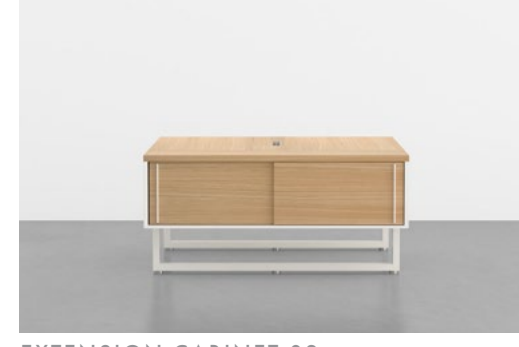

EXTENSION CABINET 02



PLANTER EXTENSION CABINET



SIZES

Lateral File, 3-High

L 29.5" D 18.75" H 41.6"
L 750mm D 476mm H 1056mm

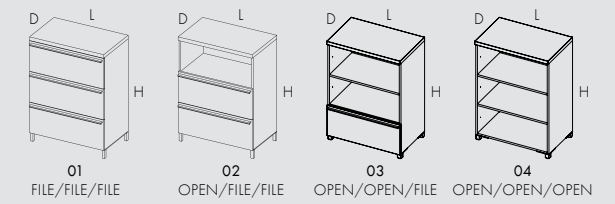

Lateral File, 2-High

L 29.5" D 18.75" H 29.5"
L 750mm D 476mm H 750mm

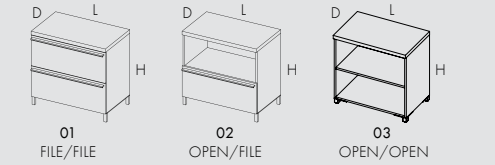

Double Lateral File, 2-High

L 59" D 18.75" H 29.5"
L 1500mm D 476mm H 750mm

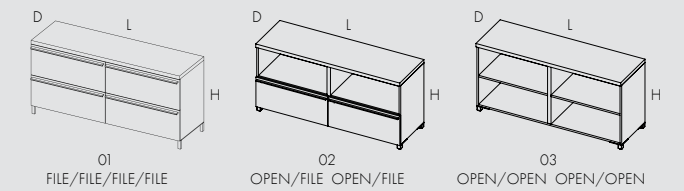

Rolling Pedestal

L 15" D 20.75" H 25"
L 381mm D 527mm H 635mm

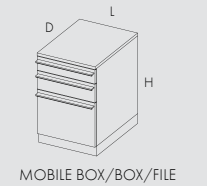

MOBILE BOX/BOX/FILE

Low Pedestal

Drawers available on right or left side.

L 36" D 15.75" H 20"
L 914mm D 400mm H 508mm

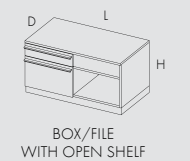

BOX/FILE WITH OPEN SHELF

Overhead Cabinet

L 47.25" D 15" H 15"
L 1200mm D 381mm H 381mm

L 59" D 15" H 15"
L 1500mm D 381mm H 381mm

L 71" D 15" H 15"
L 1800mm D 381mm H 381mm

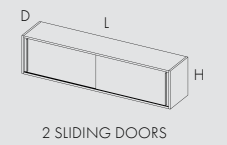

2 SLIDING DOORS

Extension Cabinet

Only available for the bench system. Extension with planter also available.

L 59" D 15" H 16.375"
L 1500mm D 381mm H 416mm

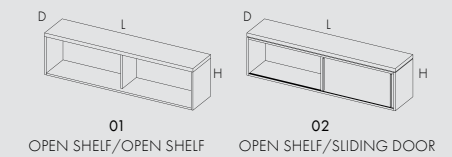

01 OPEN SHELF/OPEN SHELF

02 OPEN SHELF/SLIDING DOOR

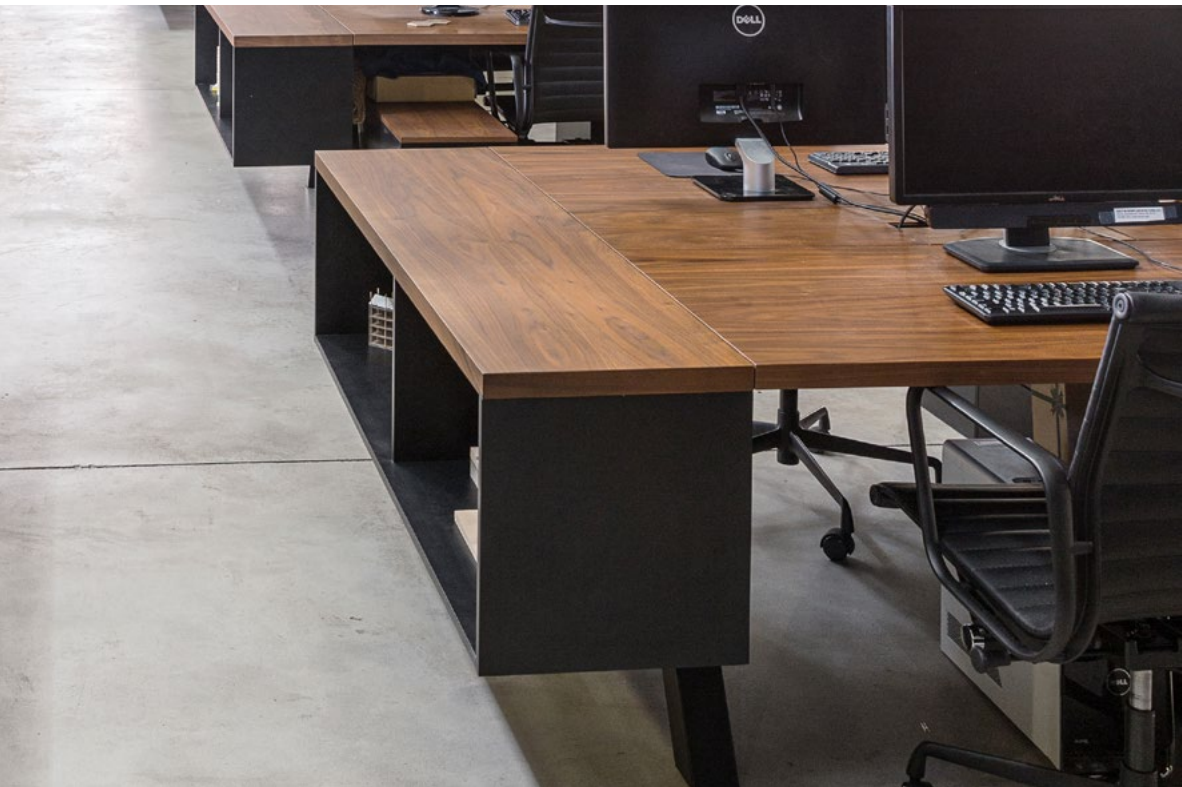

FINISHES

Top



1 2



3 4 5

Laminate

- 1 White
- 2 Black

Wood

- 3 Natural Oak
- 4 White Washed Ash
- 5 Walnut

Body



1 2

Lacquer

- 1 White
- 2 Black

Base

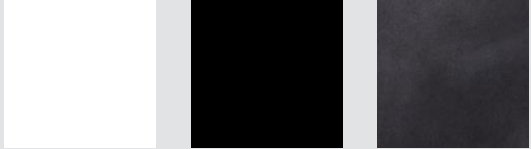

1 2 3

Metal

- 1 White
- 2 Black
- 3 Uhuru Black



CONTRACT SOLUTIONS

Every project we take on is unique—from the team, to the discovery process, to the design. This tailored approach to each project allows us to create exceptional, brand-specific furniture solutions for our clients. At Uhuru, we want your brand to stand out. Whether you're looking to adapt a standard design, find a manufacturing solution, or develop your furniture standards, we're here to help you realize those goals.

CONTRACT SOLUTIONS

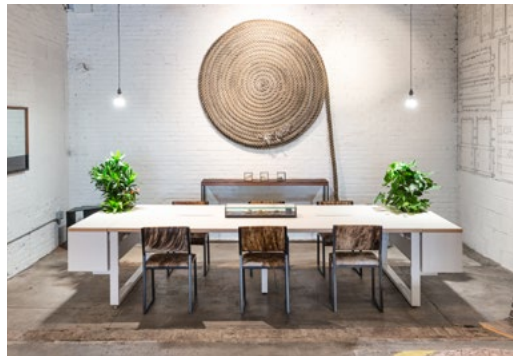

MODIFIED STANDARD PRODUCT

Modify the color, profile, finish or upholstery of an Uhuru piece to make your own exclusive design. Additionally, our MINIM Workplace collection offers products with customizable elements, easily adaptable for any office configuration or interior aesthetic.

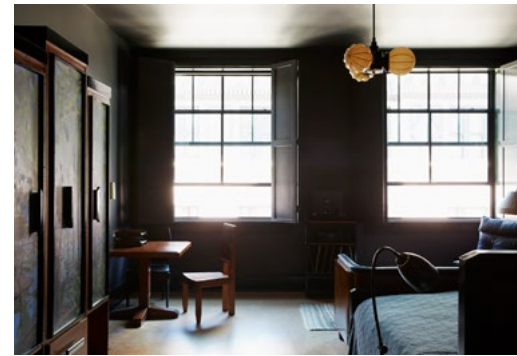

CUSTOM MANUFACTURING

We started out as makers, and have over fifteen years of experience manufacturing OEM designs and providing custom furniture solutions. With an expert team and supply chain, we have the right domestic and overseas resources to manufacture small to large volume projects.



BRAND STANDARDS

Informed by your larger vision, we create products, furniture, and fixtures that align with your company's mission. This collaboration is great for brands with several locations looking to achieve a cohesive interior and furniture design language.



CAFE

Over the past fifteen years, we have conceptualized, designed, and built exclusive lines of tables, chairs, and banquettes for cafes to fine dining restaurants including Shake Shack, Dos Toros, Sweetgreen, Lillia, among others. We start with a brand's design vision and build tailored packages of communal dining and seating options. We provide design engineering to ensure that our restaurant furniture stands up to high-traffic usage.

CLIENTS + PARTNERS

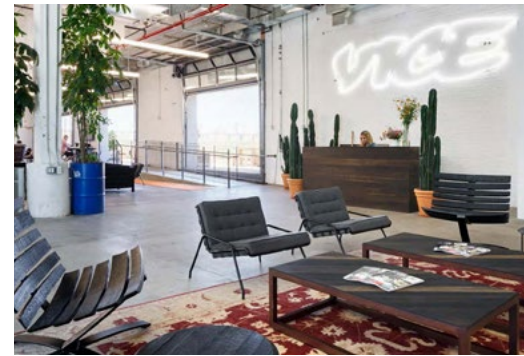

WE WORK WITH MISSION DRIVEN BRANDS

CO WORKING

Industrious Office
Knotel
WeWork
A/D/O

FINANCE

Dow Jones
JPMC
American Express
Fidelity
Federal Reserve
Two Sigma
Wells Fargo
Battery Ventures
Designworks Investments
Bank of America

TECH

Google
Slack
Snapchat
Hello Fresh
Genentech
Avaya
Nantronics
Pinterest
Squarespace
Spotify
Twitter

HOSPITALITY

1 Hotels
Ace Hotel
Hilton
Grand Hyatt
Starwood
Marriott
Hoxton
Stumptown
Equinox
Top Golf
Yellowstone Club
Kimpton
Sister City
Aloft
Sweetgreen
Shakeshack
Soundview
Starbucks
OTG
Bareburger
Lilia
Spring Natural
Soho House
Irving Farm
Rucola
Dos Toros
Essex Market

CREATIVE

Steelcase
Motivate Co
O+A
Paradigm Talent Agency
Hodinkee
Warner Music
Grailed
IPG
Translation Media
Cross Media
Nexon
Engine Shop
Disney
Kargo
Designit Wipro
Pioneer Works
Vice Media
A24
NBC
Fitz and Co
Dietl
Project Worldwide
Pace Gallery
Wanted Design
James Cohan Gallery
Reform Alliance
Wieden + Kennedy

CONSUMER GOODS

Away
Heatonist
Shinola
Sony
Bergdorf Goodman
Nuts.com
Adidas Y3
Lululemon
Weight Watchers
Glossier
Fresh Beauty
Carson Street Clothiers
Kit & Ace
FjallRaven
Converse
Nike
Saks Fifth Avenue
Paypal
Tommy Hilfiger
WelleCo
Mitsubishi
Unilever
Tiffany & Co.
Devacurl
Calvin Klein
Patagonia
MLB





U H U R U

185 Van Dyke St.
Brooklyn, NY 11231
718 855 6519

01 23 20

Copyright © 2020 Uhuru Design

UHURUDESIGN.COM

info@uhurudesign.com