

BT MEN

Volume Two

lookbook





BT MEN

Volume Two

lookbook

www.brooklyntweed.com

CONTENTS

OUTPOST	6
COLLECTION	8
	10 Longfellow Cardigan
	14 Albion Pullover
	16 Bradbury Raglan
	20 Crag Hat
	24 Sawyer Henley
	28 Carbon Pullover
	32 Oshima Pullover
	34 Denali Pullover
	38 Snare Cap
	40 Rift Pullover
	44 Dunaway Scarves
	48 Jackdaw Pullover
	50 Shield Cardigan
ALL IN THE NEIGHBORHOOD	54
PATTERN INFORMATION	62
OUR YARNS	90
DESIGN TEAM	106
CREDITS	108





OUTPOST

Putting together a men's collection is always a special treat for me. Although BT serves a customer base that's primarily female, my journey as a designer really began with menswear, generating patterns I wanted to knit and wear myself whenever my search for specific garment designs to suit my own wardrobe tastes proved unfruitful.

For our second installment of BT Men ([we published our first back in July 2013](#)), I envisioned shooting the garments on real guys rather than professional models—friends of friends, more realistic stand-ins for the partners, brothers, sons and of course(!) male knitters who will wear these designs for work and play.

I liked the idea of a shoot that felt easy, relaxed and fun—qualities I like to keep in mind when dressing myself. These ideas also aligned with our inspiration for this collection: utilitarian garments with a stylish flair for every day (and every kind of guy) that are crafted with thoughtful, subtle

details. We asked our “first-time models” to bring items from their own closets that we could pair with the knits, and to play an active role in the styling process—keeping their own comfort and personal style in mind throughout. Our five “real guys” all ended up being naturals in front of the camera and I love how their personalities come through in the images.

We hope this approach helps you choose just the right sweater or accessory for yourself or for the men in your life and gives you a chance to have some fun along the way.

Thanks for your continued support of what we do here—we hope you enjoy this fun collection!

All my very best,

A handwritten signature in black ink that reads "Jared".

Jared Flood





Collection



LONGFELLOW
Michele Wang





ALBION

Michele Wang





BRADBURY

Julie Hoover

CRAG

Jared Flood







SAWYER

Julie Hoover





CARBON

Véronik Avery





OSHIMA
Jared Flood



DENALI
Norah Gaughan

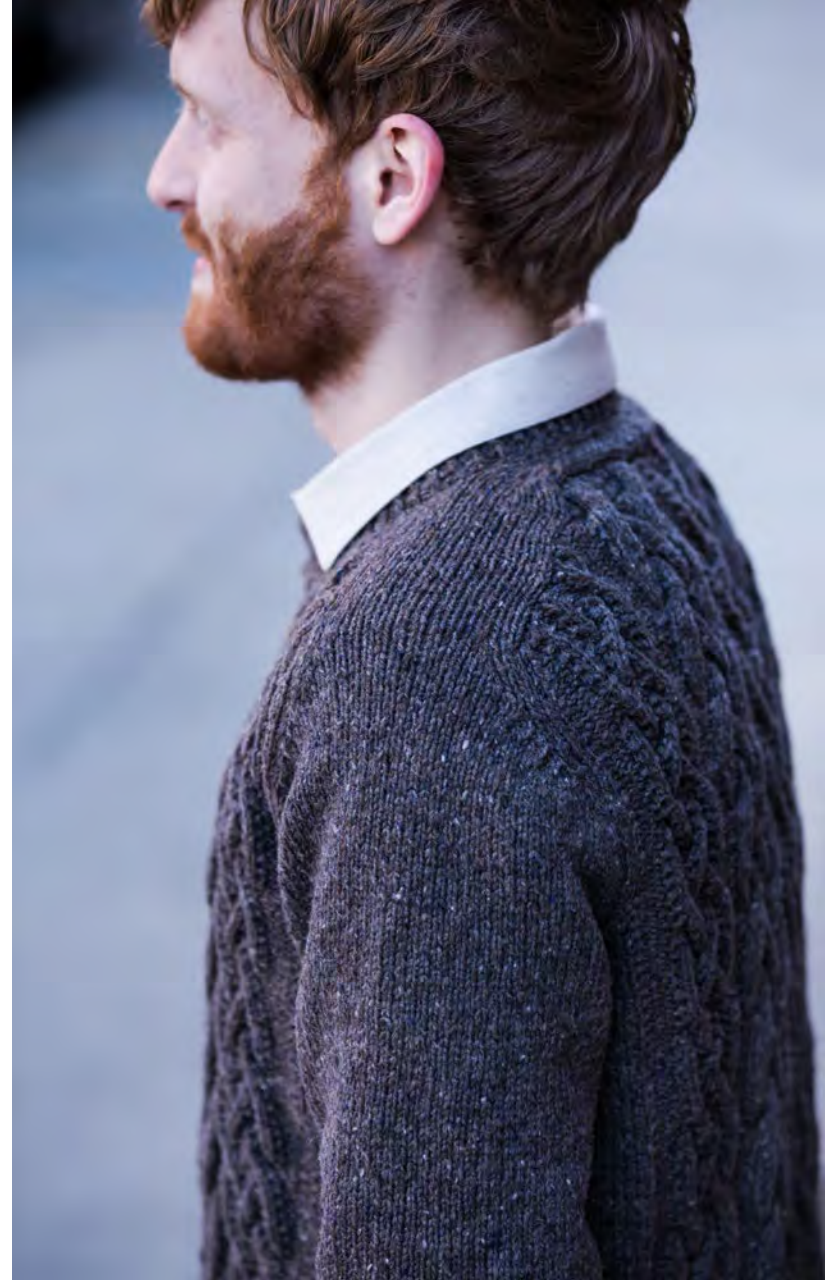



SNARE

Norah Gaughan





RIFT
Jared Flood





DUNAWAY

Julie Hoover





JACKDAW
Norah Gaughan





SHIELD

Véronik Avery



ALL IN THE
NEIGHBORHOOD

Our Shoot in Jersey City's Historic Downtown



When we began mapping out our second BT Men photoshoot, we knew we wanted to set the stage right in our own backyard—the historic downtown neighborhood of Jersey City, NJ.

Jersey City has been home to Brooklyn Tweed Headquarters since 2013. As we sought more space than was available in our old Brooklyn neighborhood of Greenpoint, we discovered this hidden jewel just across the Hudson from lower Manhattan. It has been a wonderful place to grow our business and an inspiring community to be a part of for the past two years.

Jersey City is the second-largest city in the state, a harbor town and industry hub that shares New York City's fertile diversity and colorful immigrant history. Though only a

single hop on the subway from downtown Manhattan—closer to the bright lights than most of the trendy Brooklyn neighborhoods—Jersey City somehow managed to stay sleepy and more financially accessible for artists and small businesses even as the gentrification of Brooklyn and Queens has powered forward at an astonishing pace.

In recent years, inevitably, the area has been discovered and is suddenly blooming; new restaurants and creative ventures are sprouting on every block around the Brooklyn Tweed offices and the redevelopment energy is palpable. It's been an exciting time to live here, and as we gear up for another big move this spring—west, to Portland, Oregon—we wanted to bottle some Jersey City flavor while we still could to pay homage to this wonderful neighborhood we've come to call home.



We reached out to the owners of *Porta*, a new modern Italian restaurant in a big, rustic setting just down the street from our headquarters. They loved the idea of hosting a shoot and let us have the run of the building to create the images for this collection. We shot on a Saturday morning before the venue opened to customers and then moved downstairs or up to the rooftop bar when hungry people began flowing in for weekend brunch. It was a relaxed and fun day (and there was plenty of the most delicious pizza at hand whenever we needed a break).

We also took the camera and our five models out to walk some of our favorite side streets. We're going to miss the graceful pre-war brownstones that have served as the backdrop for many Brooklyn Tweed images, the diverse group community that makes up our neighborhood, and the beautiful history of this place as a gateway for so many American families during the 19th and 20th centuries.

Thanks for a great run, Jersey City.



Pattern
Notes





LONGFELLOW
cardigan



Yarn: Loft
Color: Hayloft



designed by Michele Wang

About the Design

Oh, professor! This slim V-neck cardigan is knit flat in Loft and seamed. Dapper pockets begin with linings worked separately and then knit onto the fronts (making it easy to add a secret contrast color inside the pocket if you wish). A pocket edging in 1 x 1 rib keeps the pockets from gaping open. Set-in sleeves ensure a tailored fit and tubular ribbed edge treatments provide a beautiful and durable finish.

[PURCHASE PATTERN >](#)

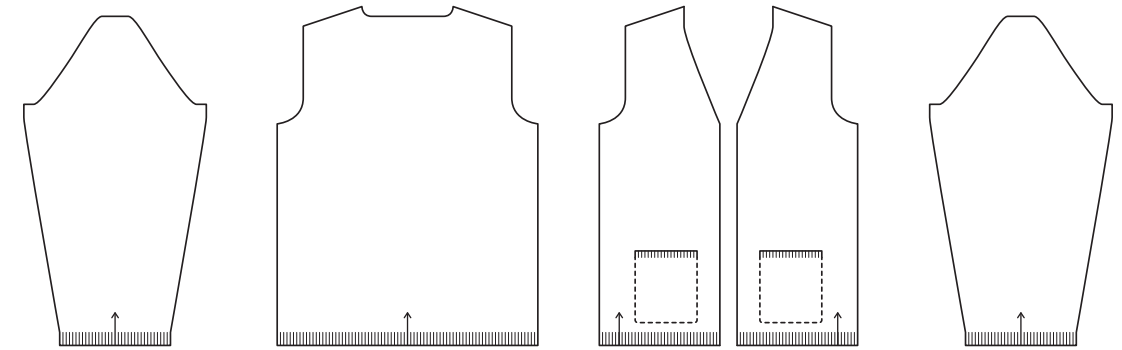

Finished Dimensions

35½ (39¾, 44, 48¼, 52¼, 56½)" circumference at chest (buttoned)

Intended Ease: + 1-3"

Sample shown is size 39¾" with + ¾" ease on model

Gauge

23 stitches & 34 rows = 4" in stockinette stitch with Size A needle(s), after blocking

Design Details

- slim v-neck cardigan
- five-piece seamed construction
- pieces are worked flat from the bottom up and seamed
- button band is picked up and worked after seaming
- long set-in sleeves and v-neck



ALBION

pullover



Yarn: Shelter
Color: Almanac



designed by Michele Wang

About the Design

Sailor style refined for the modern man. Albion is a Guernsey pullover in Shelter, featuring bands of directional chevrons worked in purl stitches for a current and classic effect. Albion knits up quickly in the round from the ribbed hem and cuffs to underarm; the yoke and set-in sleeve caps are worked flat with garter stitch selvages and seamed together. Choose a subdued neutral he can wear over brightly patterned shirts or go playful with a bold hue like Hayloft.

[PURCHASE PATTERN >](#)

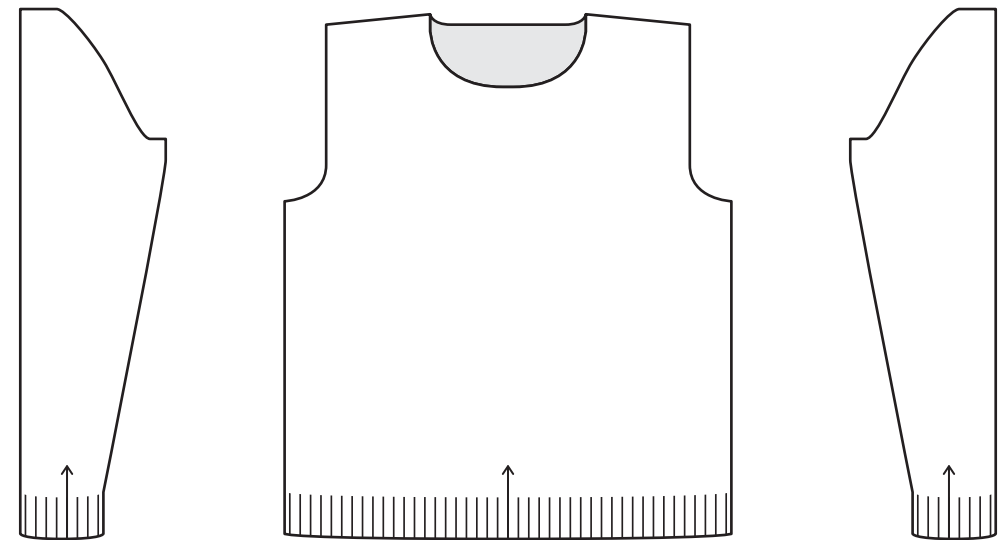

Finished Dimensions

39 (43, 46¾, 50¾, 54¾, 58)" circumference at chest

Intended Ease: + 3-4"

Sample shown is 43" with + 4" ease on model

Gauge

20½ stitches & 33 rows/rounds = 4" in stockinette stitch with Size A needle(s), after blocking

20½ stitches & 37½ rows/rounds = 4" in Front or Back Chart Pattern with Size A needle(s), after blocking

Design Details

- modern Guernsey pullover
- three-piece seamed construction
- body and sleeves are worked in the round from the bottom up, then split at the armhole to work back and forth
- all-over guernsey textured patterning on body
- stockinette on sleeves and yoke
- long set-in sleeves and crew neck

About the Design



Savvy stripes: as good at the drafting table as they are for lazy Sundays at the coffeehouse with a favorite dystopian novel. Worked in pieces and seamed, Bradbury is precisely tailored through the shoulders for a neat and comfortable fit. The raglan seams are exposed for a constructed look at the yoke, and a block of the lighter color emphasizes the breadth of the shoulders. We chose a high-contrast color pairing for graphic impact; try a subtle shift between warm and cool neutrals or pair closely related shades for an entirely different feel.

BRADBURY pullover

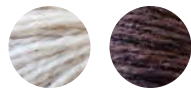

Yarn: Loft

Colors: Fossil & Pumpernickel



designed by Julie Hoover

[PURCHASE PATTERN >](#)

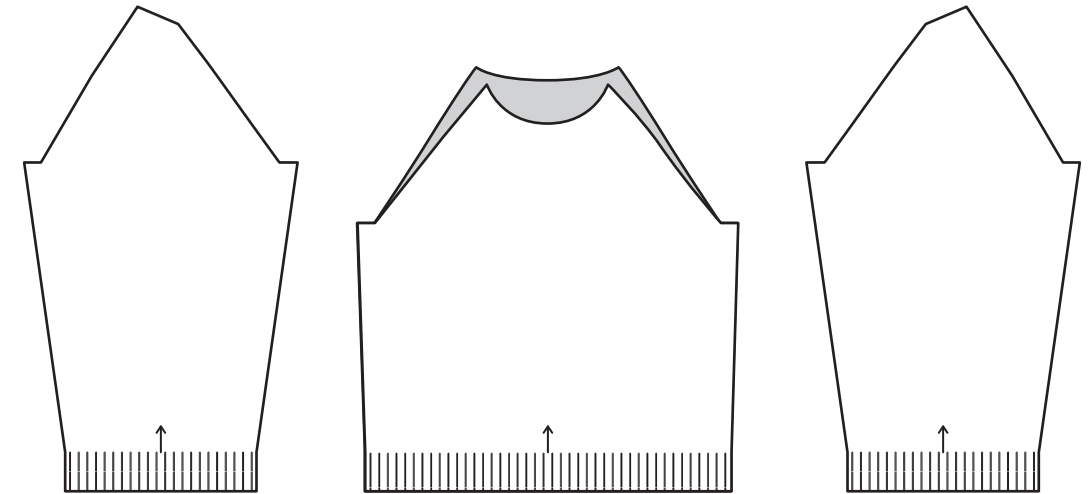

Finished Dimensions

39¼ (43½, 47¾, 51¾, 56, 60¼)" circumference at chest

Intended Ease: + #3-5"

Sample shown is size 43½" with + 4½" ease on model

Gauge

23 stitches & 34 rows = 4" in stockinette stitch with Size A needle(s), after blocking

Design Details

- striped raglan pullover
- four-piece seamed construction
- pieces worked flat from the bottom up and seamed
- stripe sequence on body and sleeves
- long raglan sleeves and crew neck

About the Design



Rhythmic all-over cables in Shelter produce a handsome, classic cap that's quick and satisfying to knit. After a short band of 1 x 1 rib, the hat breaks into a geometric motif of interlocking tiered cables. Perfect for knitters who have tried some basic cables and feel ready for a little more challenge, this design is predictable and easy to memorize. Crag's deep texture means the pattern won't be lost in dark colors, so this one is a good choice for guys who favor black, charcoal, and navy shades.

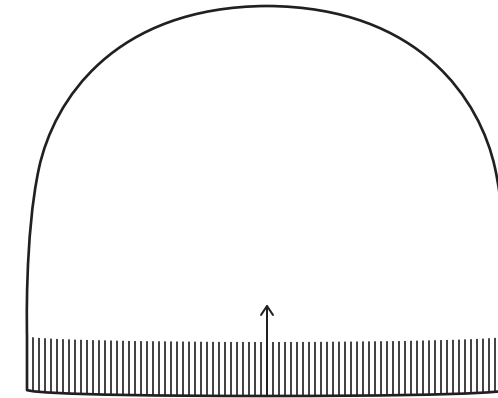

CRAG hat



[PURCHASE PATTERN >](#)

Yarn: Shelter
Color: Stormcloud



designed by Jared Flood

Finished Dimensions

21¾" circumference (to comfortably fit average adult head sizes 20-23"); 9¼" length

Gauge

26½ stitches & 30 rounds = 4" in Crag Chart pattern with Size A needle(s), after blocking

Design Details

- allover cabled cap
- worked in the round from brim to crown
- allover cable patterning and ribbed brim



About the Design

For the untrammelled outdoorsman or urban minimalist, this is Brooklyn Tweed's take on a perennial masculine favorite, the thermal Henley. Sawyer is worked in Shelter with a plush and textural fabric created by knitting into the row below. Set-in sleeves and seamed construction make this a long-wearing classic. Choose a tried-and-true menswear shade like Artifact or Almanac, go moody with Stormcloud, or inject some warm color into his wardrobe with Wool Socks (pictured) or Fauna.

SAWYER pullover



Yarn: Shelter
Color: Wool Socks



designed by Julie Hoover

[PURCHASE PATTERN >](#)

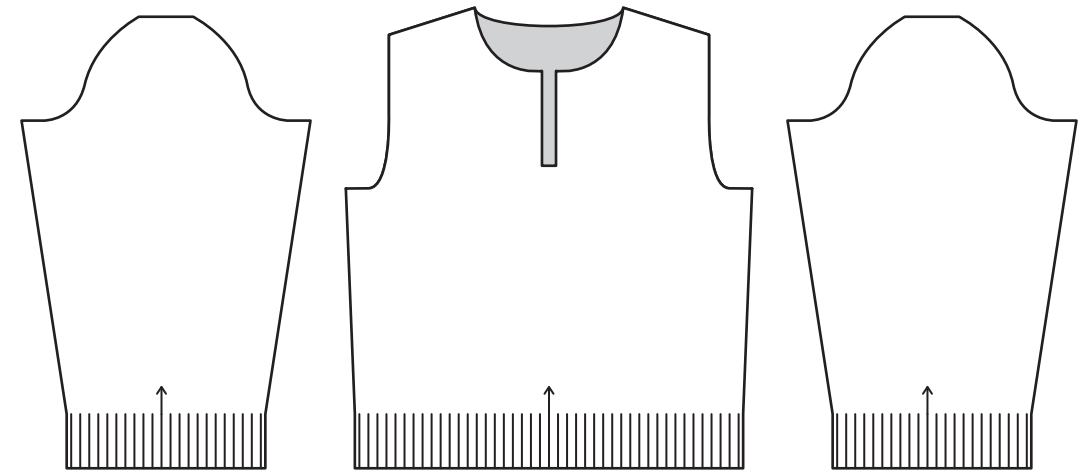

Finished Dimensions

40 (44¼, 48½, 52¾, 57, 61¼)" circumference at chest

Intended Ease: + #4-6"

Sample shown is size 44¼" with + 5¼" ease on model

Gauge

15 stitches & 40 rows = 4" in Thermal Texture Stitch with Size A needle(s), after blocking

Design Details

- thermal texture Henley with collar
- four-piece seamed construction
- pieces are worked flat from the bottom up and seamed
- all-over tuck-stitch and texture patterning
- long set-in sleeves and Henley neck



About the Design

Tech meets tradition. Futuristic stranded colorwork distinguishes this pullover, knit in two colors of Loft. The pixelated motif of interlocking diamonds creates a gradient shift from dark to light, highlighting broad shoulders (and knitting skills). Carbon is worked in the round with steeks at the armholes, and the folded contrast hem provides a canvas for an optional secret message (a charted alphabet and numerals are included in the pattern). The set-in sleeves are worked circularly to armholes, with flat caps that are sewn in once the steeks have been cut.

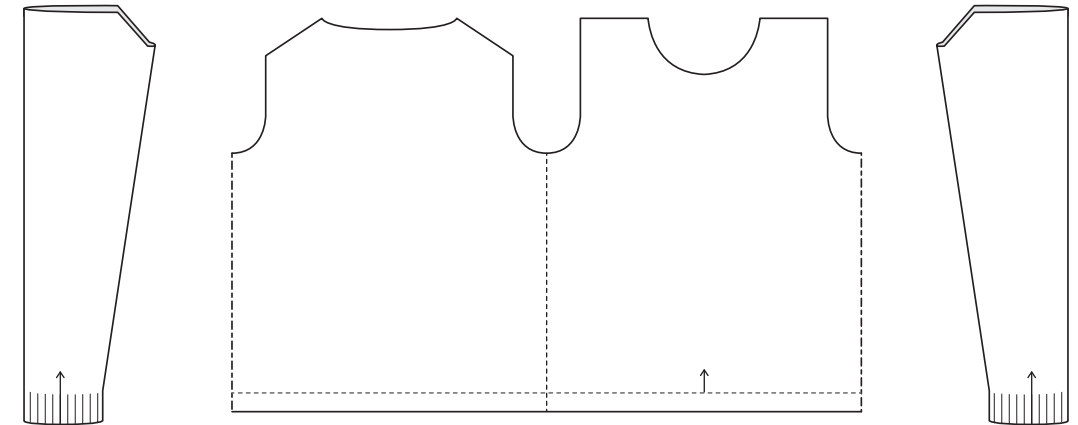

CARBON pullover



[PURCHASE PATTERN >](#)

Yarn: Loft
Colors: Soot & Sweatshirt



designed by Véronik Avery

Finished Dimensions

38½ (42¾, 47, 51¼, 55¼, 59½)" circumference at chest

Intended Ease: + 3-5"

Sample shown is size 42¾" with + 3¾" ease on model

Gauge

23 stitches & 38 rounds = 4" in stockinette stitch with Size A needle(s), after blocking

23 stitches & 34 rounds = 4" in Carbon Chart pattern with Size B needle(s), after blocking

Design Details

- pullover with colorwork yoke
- three-piece seamed construction
- body is worked in the round to the shoulder, with steeks at armhole and front neck
- sleeves are worked in the round to the underarm, then split to work back and forth
- stranded colorwork chart worked over top half of body
- alphabetical and numerical charts provided for optional colorwork message in turned hem
- long set-in sleeves and crew neck



OSHIMA

pullover



Yarn: Shelter
Color: Woodsmoke



designed by Jared Flood

About the Design

For dreamers and designers, a pullover that's equal parts strong and sensitive. This masculine version of [Jared's popular Oshima pattern](#) (designed for women in our [BT Fall 13 collection](#)) uses double-stranded Loft to create a cozy brioche yoke. Decreases for the armholes and neck opening are set in from the edges to form echoing curves like rake lines in a zen garden. The sweater is knit in the round from hem and cuffs to underarm, then the yoke and sleeve caps are worked flat. The fronts extend over the shoulders to seam to the back, adding architectural interest to the rear view as well. Fine details like fashioned decreases and tubular edges bespeak lasting quality.

[PURCHASE PATTERN >](#)

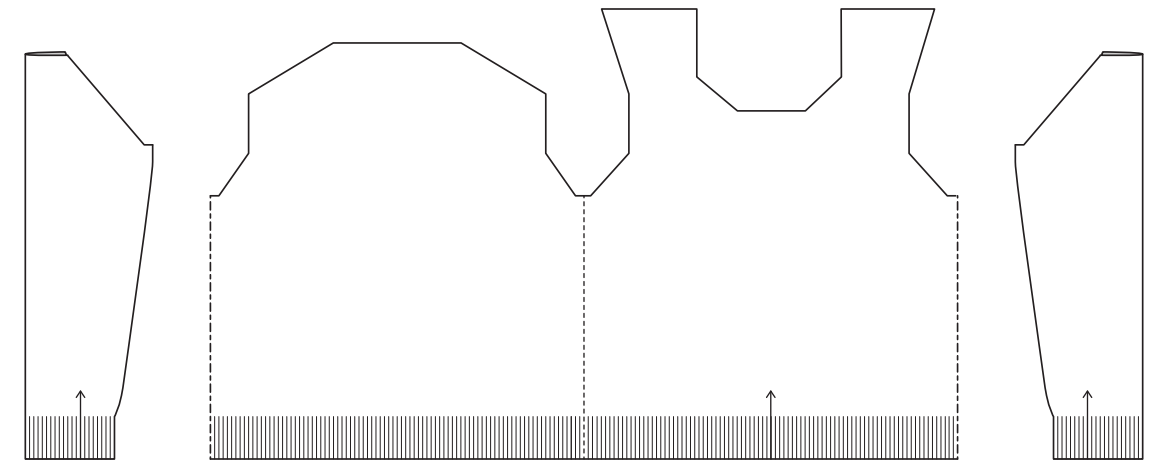

Finished Dimensions

40 (43½, 48, 51½, 56, 59½)" circumference at chest

Intended Ease: + 4-5"

Sample shown is size 43½" with + 4½" ease on model

Gauge

16 stitches & 24 rows/rounds = 4" in stockinette stitch with Size A needle(s) and yarn held double, after blocking

14 stitches & 44 rows/rounds = 4" in Brioche Stitch with Size B needle(s) and yarn held double, after blocking

Design Details

- brioche yoked pullover
- body and sleeves are worked in the round to the underarm, then split to work back and forth
- brioche rib and patterning on yoke
- long set-in sleeves and crew neck



DENALI

pullover



Yarn: Shelter
Color: Truffle Hunt



designed by Norah Gaughan

About the Design

Trailblazing good looks. A field of bone and braid cables distinguishes this modern Aran pullover in Shelter. Intentionally unmirrored, the cables broadcast a sense of syncopation. The design features thoughtful shaping through the hybrid shoulders and pleasing transitions in fabric, from busy cables to calm stockinette to twisted rib edgings. Worked flat and seamed, Denali offers just the right blend of action and mellow knitting for an adventurous intermediate.

[PURCHASE PATTERN >](#)

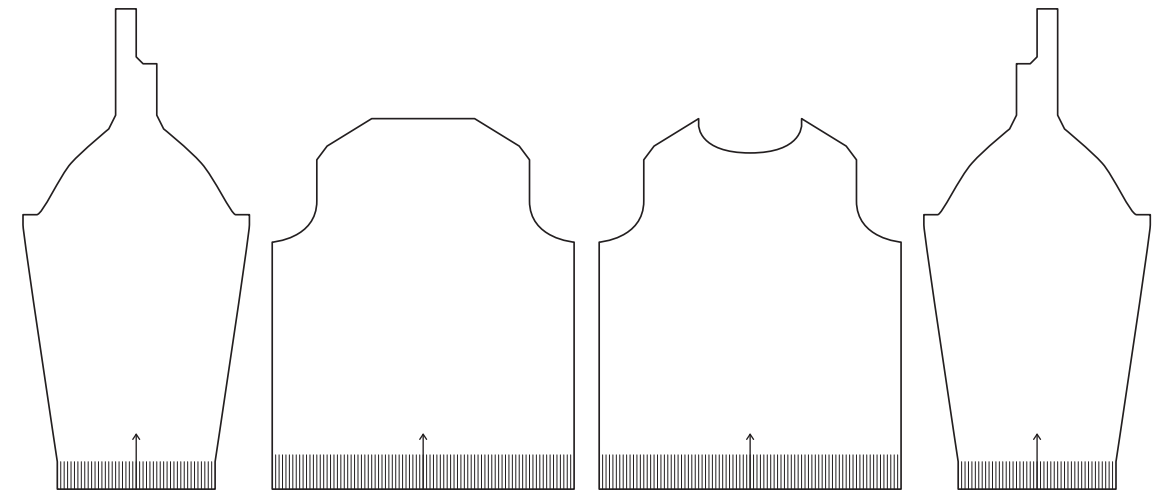

Finished Dimensions

39½ (43¼, 47¼, 51, 55¼, 59)" circumference at chest

Intended Ease: + 3-5"

Sample shown is size 43¼" with + 4¼" ease on model

Gauge

19 stitches & 28 rows = 4" in stockinette stitch with Size A needle(s), after blocking

27 stitches & 32 rows = 4" in cabled panel pattern with Size A needle(s), after blocking

Design Details

- cabled pullover with saddle shoulder
- four-piece seamed construction
- pieces worked flat from the bottom up and seamed
- allover large-scale cable patterning on body; stockinette on sleeves
- long saddle-shoulder sleeves and crew neck

About the Design



Get your cable fix with this one-skein cap in Shelter. A deep edging of twisted rib buds into an ornate cable motif that decreases to form a sunburst at the crown. The fabric is stretchy enough to fit most adult heads. Handsome in any color, this design is great for using up insurance skeins from larger projects or for playing with new shades you've been wanting to try. Snare is worked entirely from charts.

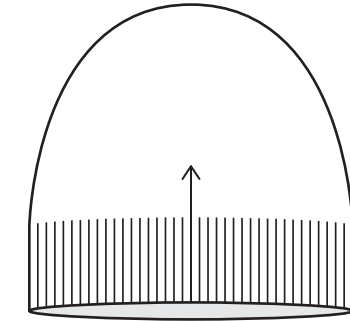

SNARE hat



[PURCHASE PATTERN >](#)

Yarn: Shelter
Color: Tent



designed by Norah Gaughan

Finished Dimensions

20¾" circumference (to comfortably fit average adult head sizes 20-23"); 9" length (7" length with rib folded up 2")

Gauge

23 stitches & 32 rounds = 4" in Snare Chart pattern with Size A needle(s), after blocking

Design Details

- twisted-stitch brimmed cap
- worked in the round from brim to crown
- allover twisted-stitch and ribbed patterning



RIFT

pullover



Yarn: Shelter
Color: Snowbound



designed by Jared Flood

About the Design

What Brando would have pulled on over that famous white T-shirt if *Streetcar* had been set farther north. Distinctive shoulders elevate this staple pullover: the sleeves are a classic set-in shape, but a ribbed motif worked from large charts creates a handsome raglan effect. Rift is knit in Shelter, worked in the round until the underarms. A generous crew neck worked with a sewn bind-off allows for a comfortable fit over collared shirts and provides a minimalist finish to coordinate with the shoulder details. Turned-back cuffs and hems in single rib lend a casually sporty touch. This sweater is designed for everyday wear, so choose a color that will work with any outfit.

[PURCHASE PATTERN >](#)

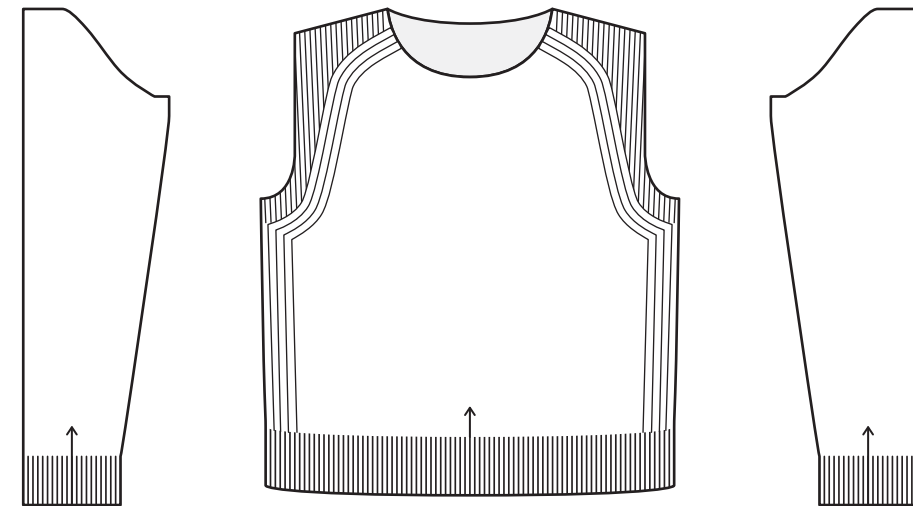

Finished Dimensions

39¼ (43¼, 47¼, 51¼, 55¼, 59¼)" circumference at chest

Intended Ease: + 3-5"

Sample shown is size 43¼" with + 4¼" ease on model

Gauge

20 stitches & 30 rows/rounds = 4" in stockinette stitch with Size A needle(s), after blocking

Design Details

- faux raglan pullover
- body and sleeves are worked in the round to the underarm, then split to work back and forth
- shaping is worked at sides and in yoke to create faux-raglan lines in rib
- body and sleeves are worked in stockinette
- long set-in sleeves and crew neck
- yoke sections worked from charts (individual charts for every size have been provided)



About the Design

This reversible scarf in slipped garter rib is a perfect project for less experienced knitters and for guys who like simple, uncomplicated style. Instructions are given for tubular edging if you're up for the challenge, but also for substituting an easier method of your choice. Knit Dunaway in Loft or Shelter – 2 skeins of Loft make a lightweight, smaller scarf; 6 skeins of Shelter make an oversized cozy muffler for the worst of the winter weather.

DUNAWAY scarf

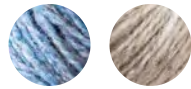

Yarn: Loft or Shelter
Colors: Faded Quilt & Woodsmoke



designed by Julie Hoover

[PURCHASE PATTERN >](#)



Finished Dimensions

Version I: 7" wide; 56" long

Version II: 8½" wide; 84" long

Gauge

Version I: 25 stitches & 46 rows = 4" in Garter & Slipped Rib Pattern with Size A needle(s) and Loft, after blocking

Version II: 21 stitches & 36 rows = 4" in Garter & Slipped Rib Pattern with Size A needle(s) and Shelter, after blocking

Design Details

- reversible garter rib scarf
- worked flat from end to end
- Version I worked in Loft, Version II worked in Shelter
- allover slipped rib and garter patterning



About the Design

Pairs well with single malt or craft beer. This handsome pullover for men who appreciate the finer things is as engaging on the needles as it is about town. Worked flat in Loft of simple shapes, Jackdaw features an original stitch motif: sections of garter rib break the surface, cross, and vanish again into a sea of twisted rib. Drop shoulders and a wide shawl collar make the most of a masculine frame, and turned-back cuffs add a touch of youthful charm. This is a long-haul project, so knit it for someone who's good company over the miles.

JACKDAW pullover



Yarn: Loft
Color: Sweatshirt



designed by Norah Gaughan

[PURCHASE PATTERN >](#)

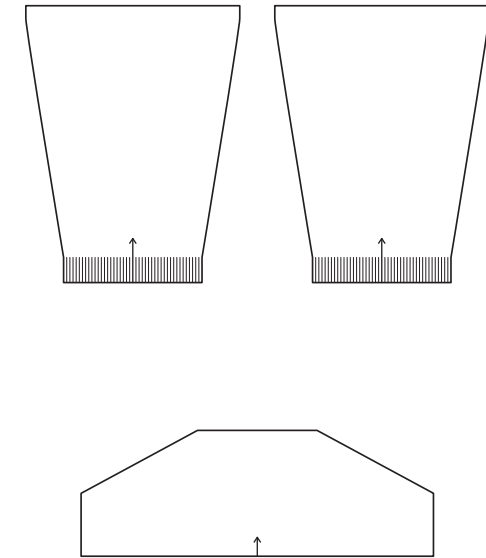
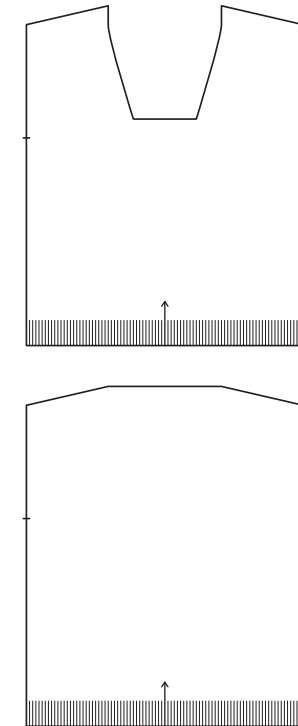

Finished Dimensions

39¼ (43¾, 48¼, 52¾, 57½, 62)" circumference at chest

Intended Ease: + 4-5"

Sample shown is size 43¾" with + 5¾" ease on model

Gauge

28 stitches & 40 rows = 4" in Jackdaw Chart pattern with Size A needle(s), after blocking

32 stitches & 40 rows = 4" in 1x1 Half-Twisted Ribbing with Size B needle(s), after blocking

Design Details

- allover cabled pullover with shawl collar
- four-piece seamed construction
- pieces are worked from the bottom up and seamed
- shawl collar is picked up and worked after seaming
- allover cable and rib patterning
- drop-shoulder long sleeves and shawl collar v-neck



SHIELD

cardigan



Yarn: Shelter
Color: Long Johns



designed by Véronik Avery

About the Design

James Dean goes to Amsterdam. This brioche masterpiece is part cardigan, part bomber jacket—a debonair outer layer for the transitional seasons. Large faux cable motifs swirl from hem to shoulders and deep pockets add vintage appeal. Modified drop shoulders ensure a neat fit despite the roomy styling, and extra-long sleeves are designed to be turned back at the cuffs. Knit in Shelter, the Shaker Rib produces a cozy double-thick fabric, so be sure to allow at least 3" of ease.

[PURCHASE PATTERN >](#)

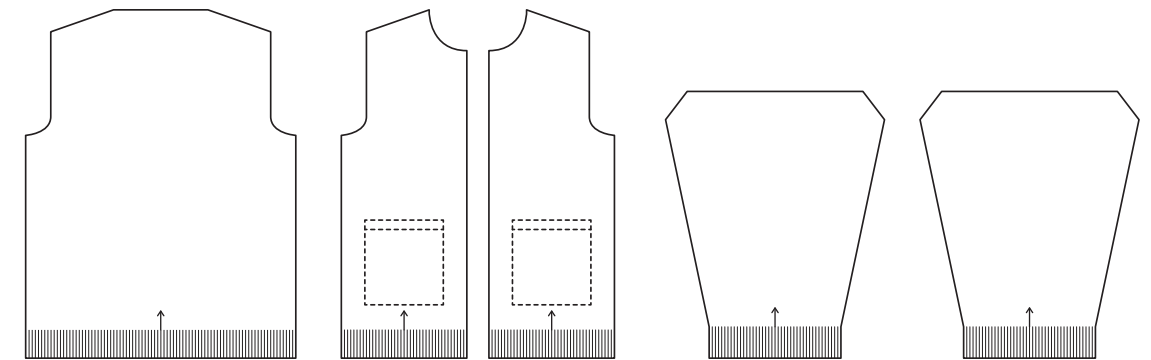

Finished Dimensions

39 $\frac{3}{4}$ (42 $\frac{3}{4}$, 47, 50, 54 $\frac{3}{4}$, 57 $\frac{3}{4}$)" circumference at bust

Intended Ease: + 3-5"

Sample shown is size 42 $\frac{3}{4}$ " with + 3 $\frac{3}{4}$ " ease on model

Gauge

21 $\frac{1}{2}$ stitches & 34 $\frac{1}{2}$ rows = 4" in Single Shaker Rib with Size A needle(s), after blocking

21-stitch panel from Right or Left Faux Cable Chart measures approximately 4" wide with Size A needle(s), after blocking

Design Details

- Shaker Rib faux cabled cardigan
- five-piece seamed construction
- pieces are worked flat from the bottom up and seamed
- all-over Shaker Rib patterning, with faux cabled bands running from hem to shoulder on front and back
- long set-in sleeves and stand-up collar

A man with dark, curly hair and glasses is shown in profile, looking out a window. He is wearing a grey cable-knit sweater. The background is a blurred view of a street with buildings and a car. The text "Our Yarns" is overlaid on the left side of the image.

Our
Yarns



WYOMING SOURCED TARGHEE-COLUMBIA FLEECE



Brooklyn Tweed yarns are born in the shadow of the Bighorn Mountains of north central Wyoming, where ranchers have raised sheep for 150 years.

Our wool comes from three Johnson County ranches that husband Targhee-Columbia sheep, a distinctly American cross of two breeds with their origins in the wide-open spaces of the West. Both are large, sturdy animals able to withstand the harsh winters and terrain of their rangeland homes. The Targhee produces a finewool with Merino-like softness; Columbia wool is stouter and lends durability and character. The combination is ideal for the lofty, warm, woolen-spun yarns Brooklyn Tweed set out to create, yarns that are soft enough to wear against the skin but also long wearing and imbued with distinctive personality on the needles.

Each Targhee-Columbia sheep will yield about 43 skeins of Loft or Shelter from a single shearing.

The fleeces travel from Wyoming to the Bollman Company in San Angelo, Texas for scouring. Bollman is a proud old company with nearly 150 years' experience in preparing wool for many purposes, including use in their signature Western hats. They handle our fleeces gently, cleaning them thoroughly but never subjecting them to the harsh chemical treatment called carbonization, which obliterates plant matter but can also damage the wool itself. As a result, our finished yarn still contains a few flecks of Wyoming flora—evidence that it comes from sheep that spend active lives in the great outdoors. We think it's worth picking out the occasional speck of hay during the knitting to preserve the purest qualities of the Targhee-Columbia fiber.



The clean wool is shipped to Pennsylvania, where G. J. Littlewood & Sons—now in their fifth generation and one of the last American survivors in the commercial dye business—create the sixteen solid colors that form the base of the Brooklyn Tweed heathered palette.

Once dyed in eye-searing colors—we start with very bright solids to retain purity of color once they're blended—the wool is baled in six-foot cubes and shipped north to Harrisville, New Hampshire.

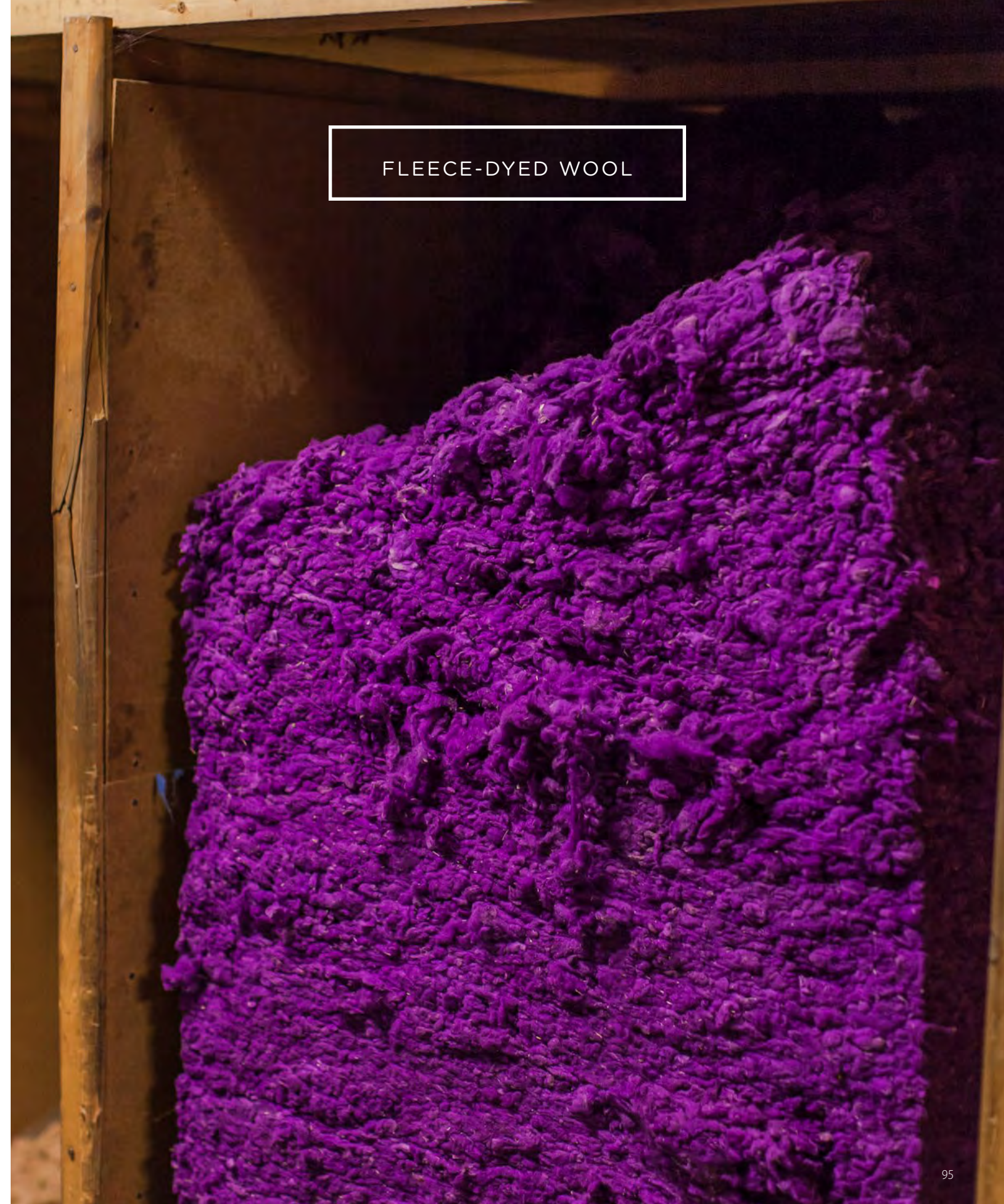

FLEECE-DYED WOOL



SPUN IN NEW HAMPSHIRE





Harrisville Designs operates in a 200-year-old mill designated as an historic landmark. The design collective was established in 1971 as a bold move to preserve a dying American craft and educate the public about one of New England's foundational industries. Here Brooklyn Tweed yarns are blended into their 32 custom heathered shades, carded, spun, plied, skeined, and finished.

The "woolen" process utilized by the mill means the yarn is spun immediately after carding rather than running the fibers through a comb or pin-drafter to smooth and straighten them. This creates a jumbly, airy cloud of wool, feather light

and wonderfully warm because so much air is trapped between the fibers. We retain that loftiness by spinning the wool quite gently, adding a little less twist than you'll find in most commercial yarns.

The result is a quietly rustic, slightly thick-and-thin yarn that's a bit more delicate than the high-twist, multi-ply structures to which many knitters are accustomed.

Once the yarn is knit and wet blocked, the stitches relax and cozy up to their neighbors to form a light, soft, and cohesive fabric that wears beautifully. Any pills that form are easily removed without damage to the surrounding fibers, so

you can keep a garment knit from Loft or Shelter looking handsome for many years.

Brooklyn Tweed is committed to producing 100% American wool yarns. We aim to offer our customers high quality knitting wools with distinctive characteristics. It gives us great pleasure to share the story and the experience of Brooklyn Tweed yarns with knitters around the world.



SHELTER

worsted weight

100% Wyoming-grown Targhee-Columbia Wool

140 yards per skein

The distinctive character of Targhee-Columbia wool shines in our versatile medium-weight yarn. Shelter is woolen spun, meaning the fibers remain in a lofty jumble that traps air and offers remarkable warmth and lightness. Its two plies are gently twisted to preserve that buoyant quality, so Shelter is a little more delicate than most commercial yarns. Woolen-spun yarns are also more adaptable in gauge, as they can compress to a dense sport weight or bloom to cohere as a gauzy fabric when worked on large needles. Shelter has a dry, soft hand and a faintly rustic nature; woolen spinning sometimes results in slightly thinner or thicker sections, and you'll find the occasional fleck of vegetable matter that proves our wool is never treated with harsh chemicals. Garments knit from Shelter achieve their full beauty after a wet blocking, as each stitch relaxes and bonds with its neighbors to produce an even, light, plush fabric with a halo. You shouldn't notice any change in gauge. Shelter is designed to be a workhorse yarn that invites cables, ribbing, textured stitch motifs, open work, plain stockinette and garter stitch. We think it's ideal for sweaters of every variety, winter accessories, and blankets.

[SHOP SHELTER >](#)



LOFT

fingering weight

100% Wyoming-grown Targhee-Columbia Wool
275 yards per skein

Fingering-weight Loft channels Targhee-Columbia wool's airy bounce into feather-light lace, accessories, and garments. Like Shelter, Loft is a woolen-spun 2-ply yarn with delicate twist, especially designed for unique lightness of hand. It's not a sock yarn, so treat it a little more gently when it's on the winder and the needles. Once your garment is blocked, the stitches will cohere in a beautifully even and sturdy fabric. Lace garments should open up to reveal stitch motifs with relatively mild blocking. Loft has great flexibility of gauge; it can be knit on 2mm (US 0) needles for a dense and durable fabric or on 4mm (US 6) needles for ethereal open work. Two strands of Loft held together can substitute for Shelter in patterns where you'd like greater stitch definition or a marled fabric of two colors.

[SHOP LOFT >](#)

PALETTE

1	Long Johns	17	Truffle Hunt
2	Camper	18	Postcard
3	Wool Socks	19	Blanket Fort
4	Embers	20	Homemade Jam
5	Hayloft	21	Thistle
6	Sap	22	Plume
7	Foothills	23	Woodsmoke
8	Fauna	24	Barn Owl
9	Tent	25	Nest
10	Birdbook	26	Meteorite
11	Artifact	27	Pumpnickel
12	Button Jar	28	Fossil
13	Faded Quilt	29	Snowbound
14	Almanac	30	Sweatshirt
15	Old World	31	Soot
16	Stormcloud	32	Cast Iron

ORDER A SHADE CARD >



DESIGN TEAM

Our in-house design team works together throughout the year to create each of Brooklyn Tweed's seasonal knitwear collections. Read more about each of our designers here!



VÉRONIK AVERY

Véronik is the founder of St-Denis Yarns and the author of *Knitting Classic Style* and *Knitting 24/7*.

Her work has appeared in countless knitting books, magazines (Interweave Knits, Knitscene, Vogue Knitting, Woman's Day), and online publications (Knitty and Twist Collective).



JARED FLOOD

Jared is owner and creative director at Brooklyn Tweed. Having received his education in 2D design and photography, he began designing knitwear in 2007 and developing yarns in 2009.

Today he spends his time doing creative development and knitwear design, along with his regular work leading the team at Brooklyn Tweed.



NORAH GAUGHAN

The author of *Knitting Nature*, among other books, Norah has published designs in Vogue Knitting, Interweave Knits and countless other publications. She recently left her full-time design director position to focus on her independent design work. A degree in Biology and Art and an upbringing in a household of freelance illustrators prepared her (albeit indirectly) for a career as a knitwear designer. Keep up with her, and see where she'll be teaching next, at www.norahgaughan.com.



JULIE HOOVER

Dedicated to clean, sophisticated, contemporary design throughout all her work, Julie retired her freelance art director business in 2011 to focus full time on her life-long passion — playing with textiles.

Based in Ann Arbor, Michigan, she is also a serious foodie and photo taker. Stay in touch with her at juliehoover.com.



MICHELE WANG

Based in New York City, Michele joined the Brooklyn Tweed Design Team in the Fall of 2011. She likes to explore the balance between comfort and trend in her work.

Her garments have been featured in knit.wear, amirisu and Vogue Knitting. Keep up with Michele at www.mishi2x.com.



CREDITS

CREATIVE

Photography
Wardrobe Styling
Photoshoot Producers

Hair
Photo Assistant
Location

Jared Flood
Stephanie Gelot
Luigi Boccia
Jess Morphew
Yuko Takahashi
Allison Page
Porta
135 Newark Avenue
Jersey City, NJ 07302
www.pizzaporta.com

FABRICATION

Sample Knitters

Christine Craig
Nicole Dupuis
Sue Jalowiec
Wannietta Kirkpatrick
Lynn Marlow
Allie Matthews
Elke Probst
Leila Raabe
Michele Saunders
Melissa Walters
Martha Wissing

PRODUCTION

Senior Tech Editing
Tech Editing

Copy Editing & Proofing

Lookbook Design
Pattern Layout
Copywriting
Social Media

Project Coordinator
Fulfillment

Customer Support
Pattern Support

Robin Melanson
Christine Craig
Sue McCain
Bristol Ivy
Leila Raabe
Jared Flood
Julie Hoover
Sarah Pope
Luigi Boccia
Jared Flood
Bristol Ivy
Jackie Eno
Dan Rollins
Allison Page
Christine Craig

MODELS

A very special thanks to the five men who helped bring our sweaters to life!



Bart



Mark



Benton



Nick



Adrian



KEEP IN TOUCH

 Facebook

 Instagram

 Pinterest

 Ravelry

 Twitter

 Google +



www.brooklyntweed.com