

ATS WITH DOUBLE BY-PASS - 40A UP TO 3200A

Description

The Mertech Life Safety PC Automatic Transfer Switches with a Double Line By-Pass are the ideal solution for transferring power from the Mains to a Standby supply or from Network to Network supplies. With Mains and Standby three phase monitoring plus full electrical and mechanical interlocking you can be confident of switching supply under fault conditions at any time. With sizes from 40 Amps all the way up to 3200 Amp using motorised changeover switches, we can cover the requirements of all your likely projects. With full conformity to the latest IEC 60947-6-1 you can confidently specify the Mertech range of Automatic Transfer Switches.

Designed for

- Health-care buildings
- Fire pump installations
- Life safety schemes
- Data centres
- Generator manufacturers

Features

- Multiple programmable parameters including delay timers, potentiometers for voltage and frequency thresholds.
- ATS in separate compartment to ensure full isolation when by-passed.
- Switching between Line to line, line to generator and OFF position selection.

Details

Supply Voltage	400V AC, 3P 4W, 50Hz
No. Phases	3 Phase 4 Wire
System Earth	Solidly Earthed
Location	Switchroom
Atmosphere	Indoor, fine particles of dust.
Ambient Temp	Max +40deg C Min + 5deg C
Enclosure Protection	IP 65 to IEC60529
ATS Standard	IEC 60947-6-1 & BS8519:2020



ATS with Double By-Pass (Layout may vary)

Definition	Life Safety
Type	ATS
Series	LS-DBP-PC
Programmable	✓
MODBUS comms via RS485	✓
3 Phase Mains Sensing	✓
3 Phase Standby Sensing	✓
ATS Control Module	✓
Auto and Manual ATS switching	✓
Manual Double By-Pass	✓
IEC 60947-6-1	✓
BS8519 : 2020	✓
IP65 to IEC60529	✓

ATS WITH DOUBLE BY-PASS - 40A UP TO 3200A

Product presentation

This quick-acting transfer switch incorporates:

1. 2 mechanically interlocked switches.
2. A quick-acting electric control unit enabling electric or manual system operation.
3. Electrical specifications compliant with product standards, and a version identification.
4. Changeover switch wiring identification.
5. Control connections.

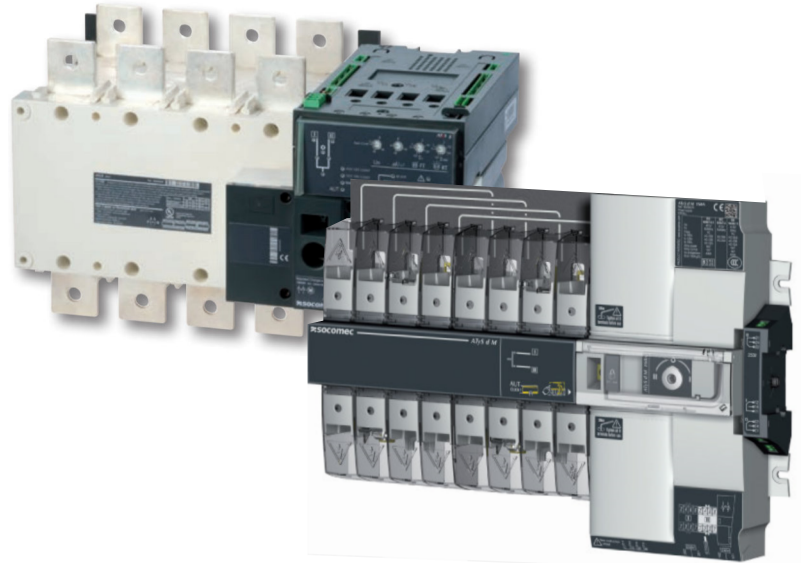

Specifications and advantages

1 - Power section:

A fully integrated and interlocked transfer switch, with high electrical performance offering microprocessor control and monitoring.

2 - Operation:

A flexible operating mechanism enabling quick motorised transfer in automatic mode or locally in manual mode for emergency operations. Features a locking device to ensure (in position zero) a secured isolation of the load (padlocked).

3 - Synchronised neutral opening & closing:

All contacts, including the neutral, are fitted on the same moving contact bar which ensures neutral referencing & avoids surges. This is SOCOMEC's solution to the overlapping neutral "requirement".

Supply types

The power supply of the switching device is required to be 220 VAC -20% to 240VAC +20% at a frequency of 50/60 Hz and has been developed so as to meet most network configurations.

Measurement accuracy: Frequency: 1 % - Voltage: 1 %

ATS Control Module

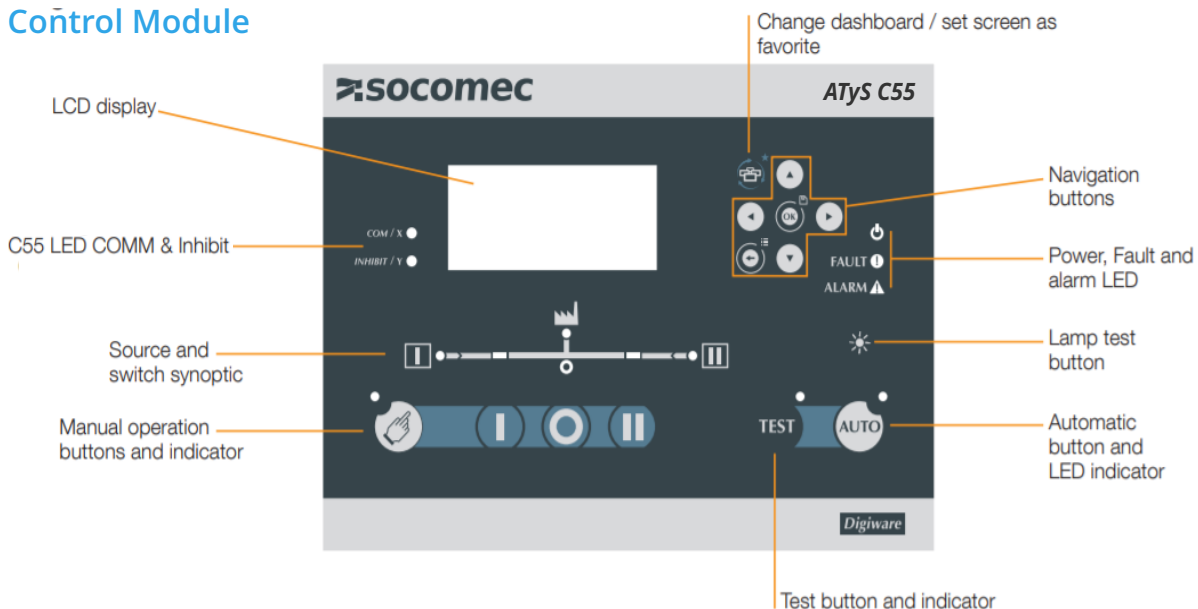

ATS WITH DOUBLE BY-PASS - 40A UP TO 160A

Characteristics

ATS Switching Device Details		40A	63 A	80 A	100 A	125 A	160 A
Dimensions (mm)	Height	700	700	700	700	700	800
	Width	1000	1000	1000	1000	1000	1200
	Depth	210	210	210	210	210	260
Frequencies		50/60 Hz	50/60 Hz	50/60 Hz	50/60 Hz	50/60 Hz	50/60 Hz
Thermal current I _{th} at 40 °C (A)		40	63	80	100	125	160
Thermal current I _{th} at 50 °C (A)		40	63	80	100	110*	125
Thermal current I _{th} at 60 °C (A)		40	50	63	80	100*	125
Thermal current I _{th} at 70 °C (A)		40	40	50	63	80*	100
Rated assigned insulation voltage U _i (V) (Power circuit)		800	800	800	800	800	800
Rated impulse withstand voltage U _{imp} (kV) (power circuit)		6	6	6	6	6	6
Rated insulation voltage U _i (V) (control circuit)		300	300	300	300	300	300
Rated impulse withstand voltage U _{imp} (kV) (control circuit)		2.5	2.5	2.5	2.5	2.5	2.5
Rated operational currents (A) IEC 60947-3 at 415VAC at 40 °C	AC 21A / 21 B	40/40	63/63	80/80	100/100	125/125	160/160
	AC 22A / 22 B	40/40	63/63	80/80	100/100	125/125	125/160
	AC 23A / 23 B	40/40	63/63	80/80	100/100	125/125	125/160
Rated operational currents (A) IEC 60947-6-1 415Vac at 40 °C	AC 33B / AC32B	40/40	63/63	80/80	100/100	125/125	125**/160
Fuse protected short-circuit withstand if using gG DIN fuses	Fuse protected short-circuit withstand (kA eff)	50	50	50	50	50	40
	Associated fuses (gG DIN)	40	63	80	100	125	160
Short-circuit capacity	Rated short-term withstand current: low 1s (kA eff)	4	4	4	4	4	4
	Rated short-term withstand current: low 30ms (kA eff)	10	10	10	10	10	10
Switching time at I _n excluding loss of supply sensing time and excluding any delay timers applicable.	I-II or II-I (ms)	180	180	180	180	180	180
	Duration of "electrical blackout" at U _n (ms)	90	90	90	90	90	90
	I-O / O-I / II-O / O-II (ms)	45	45	45	45	45	45
Consumption	Inrush current(A)	20	20	20	20	20	20
	Consumption in stabilised state (VA)	6	6	6	6	6	6
Mechanical characteristics	Number of changeovers	10000	10000	10000	10000	10000	10000
Connection cross-section (⚠️ not compatible with aluminium cables)	Minimum size (Cu mm ²), flexible and rigid	10	10	10	10	10	10
	Maximum size (Cu mm ²), flexible and rigid	70	70	70	70	70	70
Equipment class (According to IEC 60947-6-1)		PC	PC	PC	PC	PC	PC
EMC environment		A	A	A	A	A	A

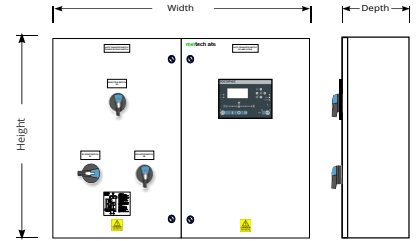

Dimensions



ATS Motorised Switching Device



Q* By-Pass Switching devices

DOUBLE LINE BYPASS SWITCH

TO BYPASS ATS:

ENSURE ATS IS ON LINE 1.
SWITCH Q1 FROM I TO 0 THEN TO II TO BYPASS.
SWITCH Q2 FROM ON TO OFF.
LEAVE SWITCH Q3 ON LINE 1(I) OR TURN TO LINE 2(II). THERE WILL BE A BREAK IN SUPPLY DURING TRANSFER FROM LINE 1(I) TO LINE 2(II).

ATS IS NOW ISOLATED FROM LINE 1 & LINE 2. ISOLATE REMOTE SIGNAL VOLTAGES ON TERMINALS S1 - S13 IN ATS. CHECK ALL ATS CONNECTIONS ARE DEAD.

TO RETURN TO ATS:

ENSURE LINE 1 IS AVAILABLE.
SWITCH Q2 FROM OFF TO ON
WAIT UNTIL ATS LINE 1 IS CLOSED.
SWITCH Q1 FROM II TO 0 THEN TO I.

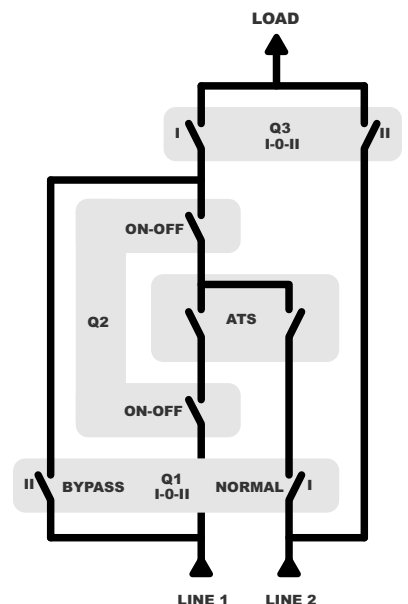

ATS WITH DOUBLE BY-PASS - 250A UP TO 3200A

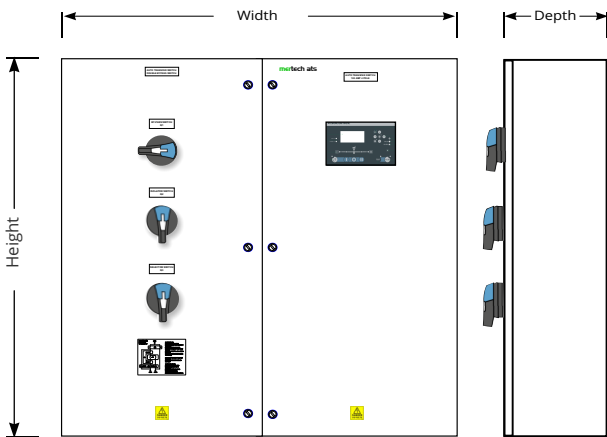

Dimensions

Rating (A)	CU Cable size (mm ²)	H (mm)	W (mm)	D (mm)	H1 (mm)
630	2 x 185	1200	1200	400	100
800	2 x 240	1200	1600	600	100
1000	4 x 150	1500	1600	600	100
1250	4 x 185	1500	1600	600	100
1600	4 x 240	2000	1600	600	100
2000	8 x 150	2000	1600	800	100
2500	8 x 185	2000	1600	800	100
3200	8 x 240	2000	1600	800	100

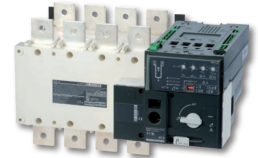

Motorised Switching Device



Q* By-Pass Switching devices

Characteristics

Rev 2 - 21.03.2023

Features according to IEC 60947-3, IEC 60947-6-1 and IEC 61439-1

Thermal current I_{th} at 40°C	250 A	400 A	630 A	800 A	1000 A	1250 A	1600 A	2000 A	2500 A	3200 A
Rated insulation voltage U_i (V) (power circuit)	1000	1000	1000	1000	1000	1000	1000	1000	1000	1000
Rated impulse withstand voltage U_{imp} (kV) (power circuit)	12	12	12	12	12	12	12	12	12	12
Rated insulation voltage U_i (V) (control circuit)	300	300	300	300	300	300	300	300	300	300
Rated impulse withstand voltage U_{imp} (kV) (command circuit)	4	4	4	4	4	4	4	4	4	4

Rated operational current I_e (A) according to IEC 60947-3

Rated voltage	Utilisation category	A/B	A/B	A/B	A/B	A/B	A/B	A/B	A/B	A/B	A/B
415 VAC	AC-21 A / AC-21 B	250/250	400/400	630/630	800/800	1000/1000	1250/1250	1600/1600	-/2000	-/2500	-/3200
415 VAC	AC-22 A / AC-22 B	250/250	400/400	630/630	800/800	1000/1000	1250/1250	1600/1600	-/2000	-/2500	-/3200
415 VAC	AC-23 A / AC-23 B	200/200	400/400	500/630	800/800	1000/1000	1250/1250	1250/1250	-/1600	-/1600	-/1600

Rated operational current I_e (A) according to IEC 60947-6-1

Rated voltage	Utilisation category	250	400	630	800	1000	1250	1600	2000	2500	3200
415 VAC	AC-31 B	250	400	630	800	1000	1250	1600	2000	2500	3200
415 VAC	AC-32 B	200	400	500	800	1000	1250	1250	2000	2000	2000
415 VAC	AC-33 B	200	200	400	800	1000	800	1000	1250	1250	1250

Rated operational current I_e (A) according to IEC 61439-1

Rated voltage	Ambient air temperature:	250	400	630	800	1000	1250	1600	2000	2500	3200
415 VAC	20°C	250	400	630	800	1000	1250	1600	2000	2500	3200
415 VAC	35°C	250	400	630	770	1000	1130	1450	2000	2500	2960
415 VAC	50°C	250	360	570	695	900	1030	1200	1801	2500	2660

Conditional short-circuit current with gG DIN fuse, according to IEC 60947-3

Prospective fuse protected short-circuit withstand at 415 VAC (kA rms)	50	50	50	50	50	50	100	100	/	/	/
--	----	----	----	----	----	----	-----	-----	---	---	---

Connection

Recommended CU cable cross-section (mm ²)	120	240	2 x 185	2 x 240	4 x 150	4 x 185	4 x 240	8 x 150	8 x 185	8 x 240
---	-----	-----	---------	---------	---------	---------	---------	---------	---------	---------

Power supply

Min./max. power (VAC)	166/332	166/332	166/332	166/332	166/332	166/332	166/332	166/332	166/332	166/332	166/332
-----------------------	---------	---------	---------	---------	---------	---------	---------	---------	---------	---------	---------

Control supply power demand during transfer

Demand/rated power (VA) - ATyS r	276/115	276/115	276/150	276/150	460/184	460/184	460/230	812/322	812/322	812/322
Demand/rated power (VA) - ATyS g, p	298/137	298/137	298/172	298/172	482/206	482/206	482/252	834/344	834/344	834/344