

1/89TH SCALE SPACEX FALCON 9 DRAGON II BUILDERS KIT

DISCLAIMER - *The products sold by Boyce Aerospace Hobbies are intended for display and/or flight with use of explicitly stated model rocket motors. Launching of model rockets may be dangerous; use our products at your own risk. Boyce Aerospace Hobbies is not responsible for any damages or injuries incurred from the use or misuse of our products. Our kits are not intended to be modified or used with motor sizes different than stated. The product should be purchased by an adult and if used by a minor, under the supervision of a parent at all times.*

Additional Parts Needed to Complete Your Model:

- 2) Lengths of BT-60 body tube
 - 1) Length of BT-50 24mm motor tube
 - 2) BT-60 Couplers
 - 1) BT-50 24mm motor block
 - 1) Length of shock cord
 - 1) 24" parachute
- Assorted paints, glue, sandpaper and assorted modeling tools.

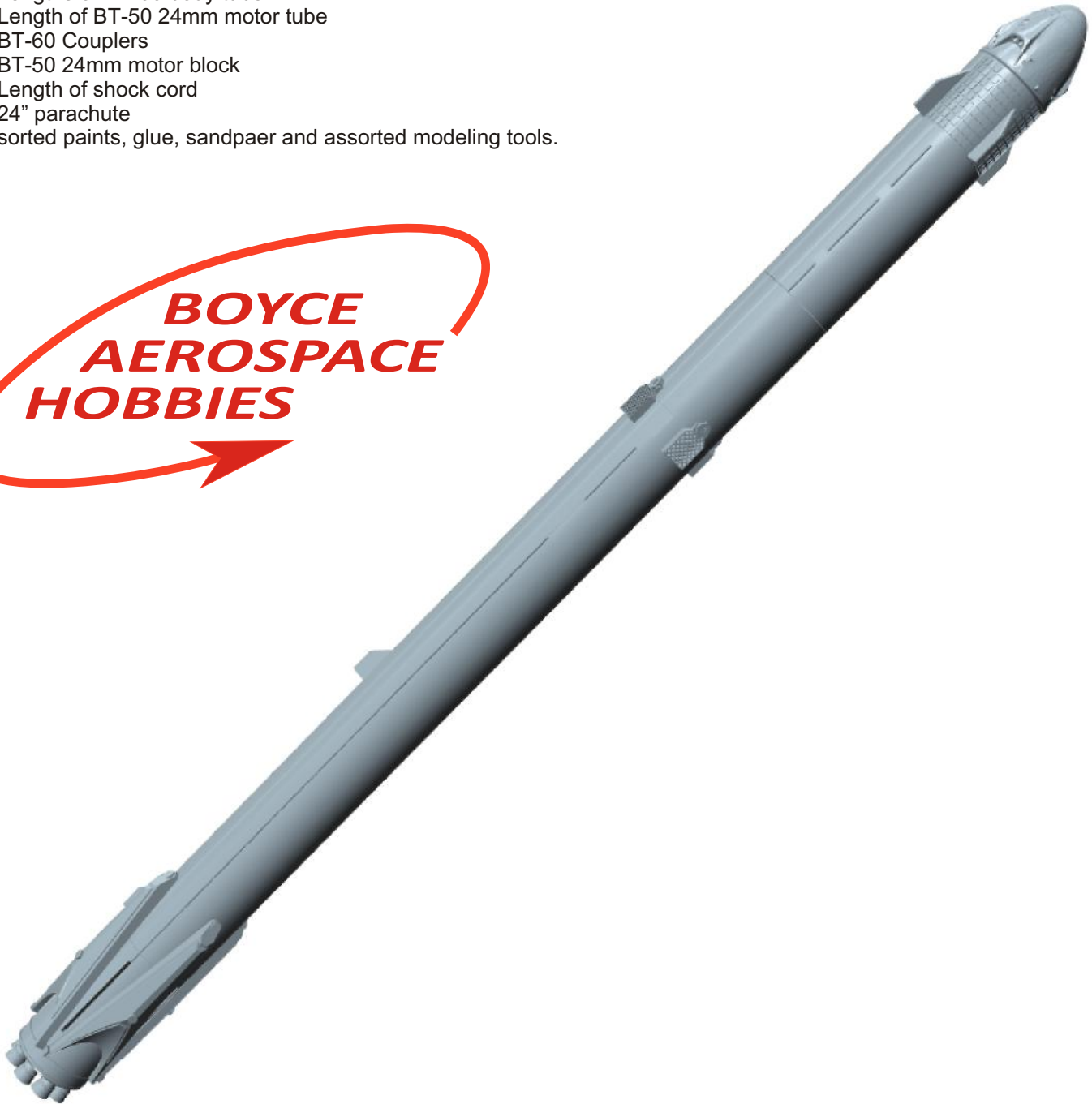

SpaceX Falcon 9 Builders Kit

Thank you for purchasing a Boyce Aerospace Hobbies Space X Falcon 9 Builders Kit. Please review the drawings below before gluing and assembling your kit.

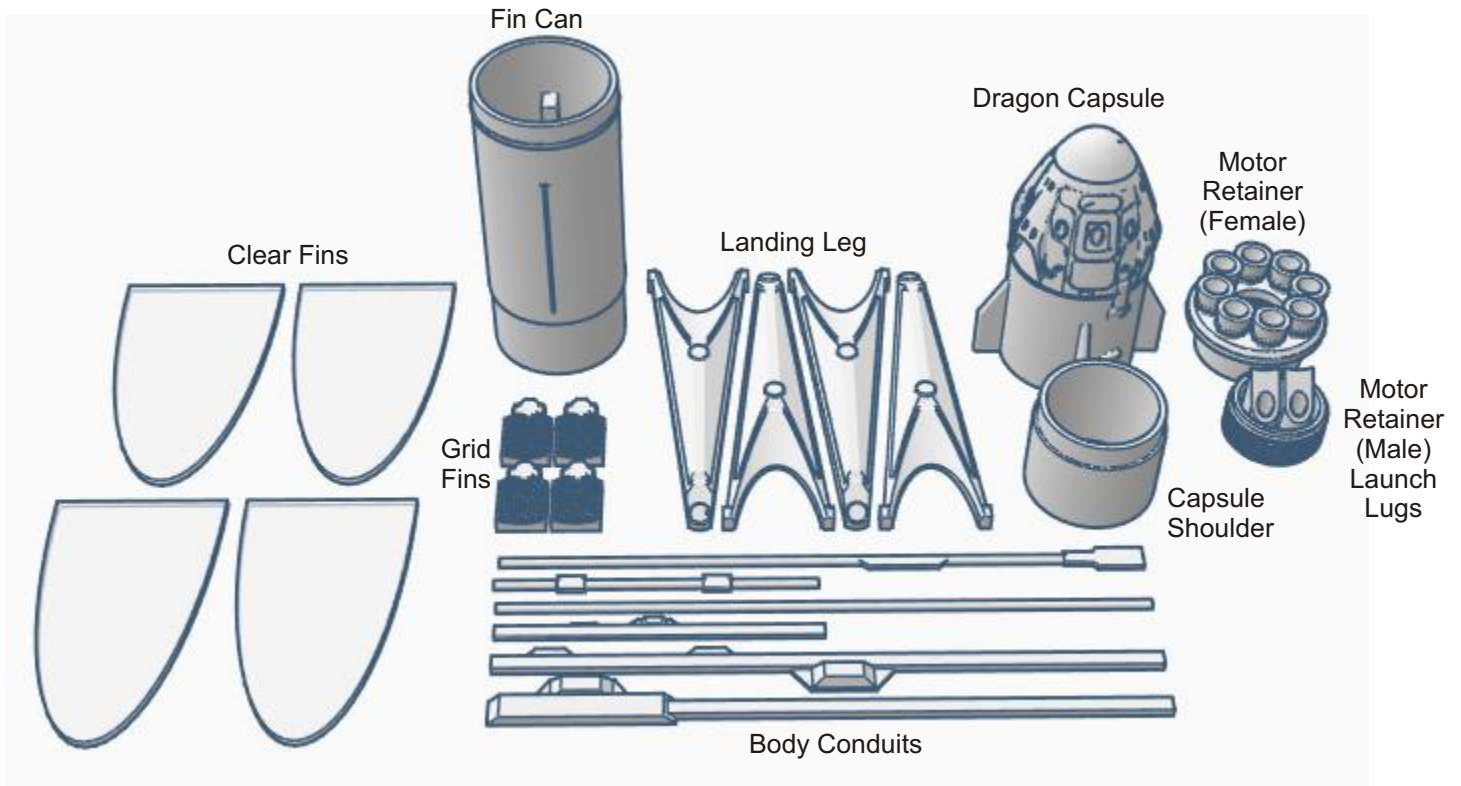

1

Remove and sand the grid fins and landing legs from their "raft". The parts are removed by flexing the raft away from the parts. If the parts are stubborn you can slide a sharp hobby knife or razor blade under the part and work around the part perimeter. Use 220 grit dry sandpaper to sand away the layer lines on the top and side surfaces of the landing legs and grid fins. Wrap a piece of 220 grit sandpaper around a BT-60 tube and sand the bottom sides of the parts to make sure they are conformal and fit flush against a BT-60.

220 Grit sandpaper wrapped around tube

Sand in this direction

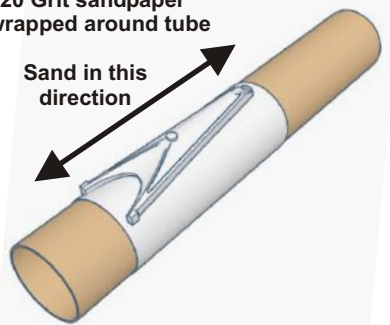

220 Grit sandpaper wrapped around tube

Sand in this direction

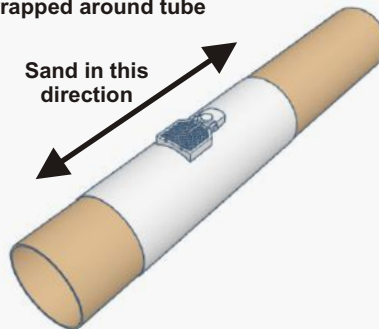

2

Carefully sand the body conduits while they are still on the raft. Use 400 grit sandpaper so you don't accidentally remove too much plastic. When the sanding is complete, carefully remove the conduit parts from their "raft". The easy way is to use a sharp razor knife under each part after flexing the raft away.

Using 220 grit sandpaper sand the fin can in all exterior areas. Don't sand the shoulder of the fin can unless it is too tight when tested for fit in a BT-60 tube. Sand the motor retainer parts if needed. Finally sand the DSLA nose cone and shoulder with 600 grit wet/dry sandpaper in a sink or bucket of water.

SpaceX Falcon 9 Builders Kit

3

Cut the BT-60 and BT-50 body tubes to the lengths listed below:

- BT-60 First Stage Tube - 363.5 mm
- BT-60 Interstage Tube - 77.5 mm
- BT-60 Second Stage Tube - 99.5 mm
- BT-50 Motor Tube - 152.5 mm

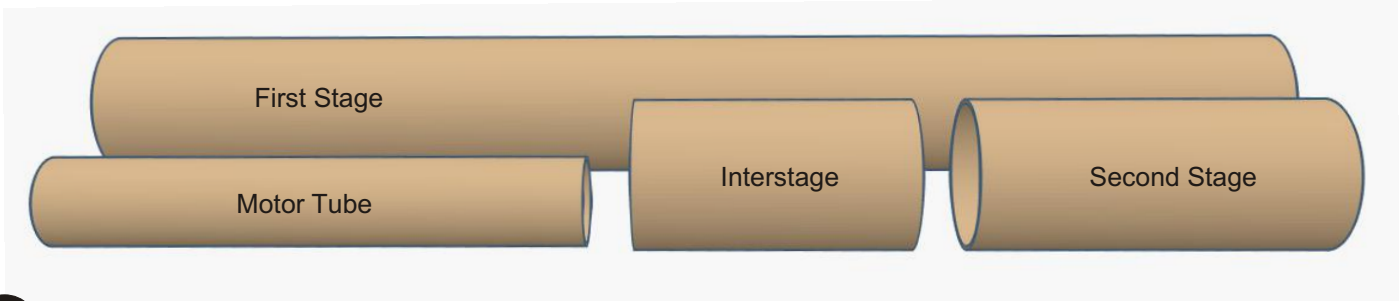

4

Carefully cut out the three panels of body wrap decals. Use a straight edge and a sharp hobby knife to cut each panel out. Do the best you can to cut the top and bottom lines off the panels (as close as possible to the line but still cutting them off). The side panel lines are not as critical because they will be covered with the body conduits.

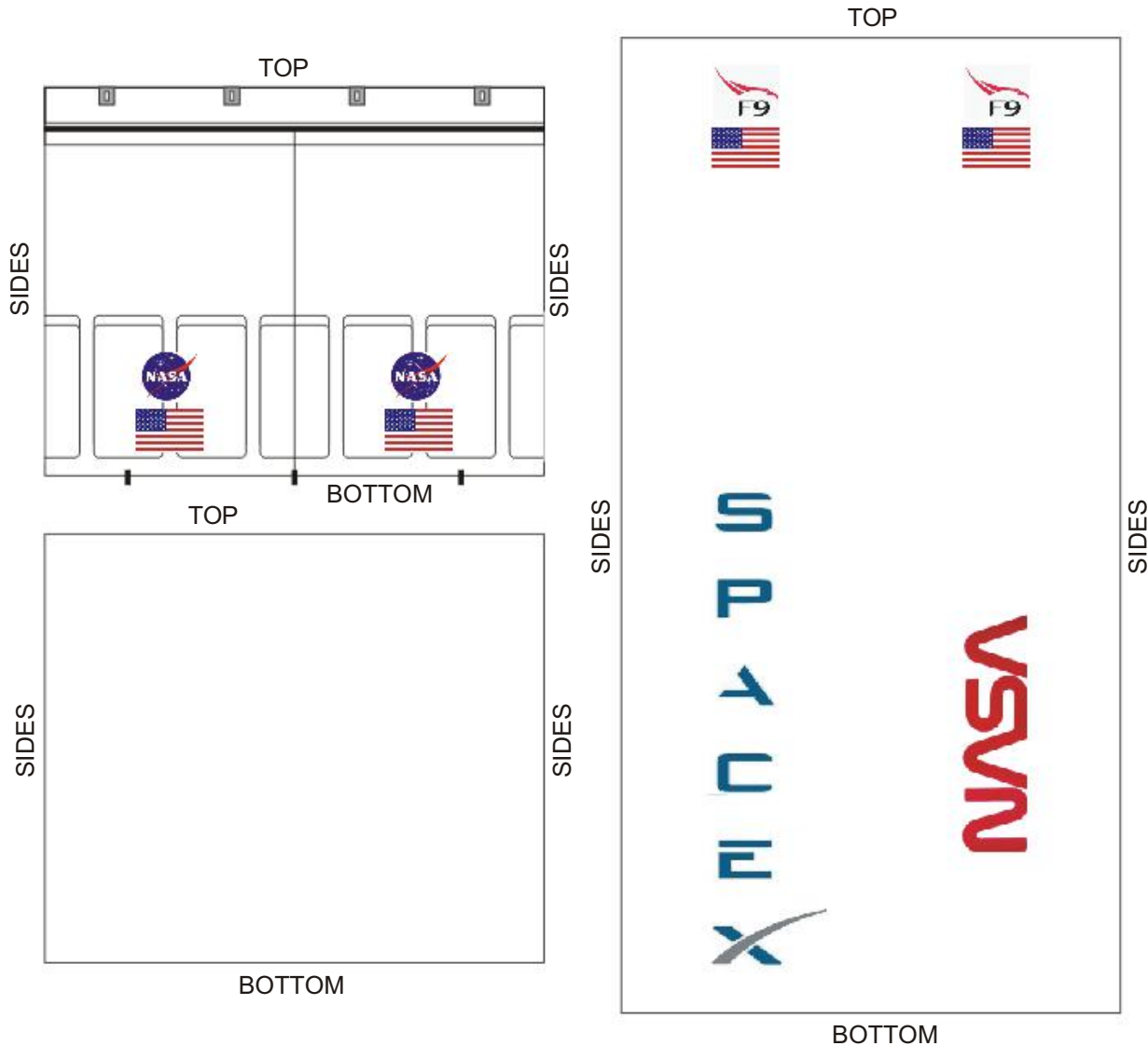

SpaceX Falcon 9 Builders Kit

5

Apply the body wrap decals as follows. Start with the second stage body tube and using a door jamb or a piece of angle aluminum draw a pencil line in the centerline of the tube parallel along the length of the tube. Peel back the right edge of the decal about a quarter of an inch and align it along the pencil line and even with the top of the tube. With the backing on the rest of the decal wrap test fit it by wrapping it around the tube to make sure it is square with the tube. Adjust the starting edge as needed. When the decal is in the correct position peel the rest of the backing off the decal and slowly wrap it around the tube making sure to press out air bubbles as you wrap. When correctly applied the decal wrap should just barely overlap the starting edge of the decal. Trim any excess decal off the bottom of the tube with a razor knife.

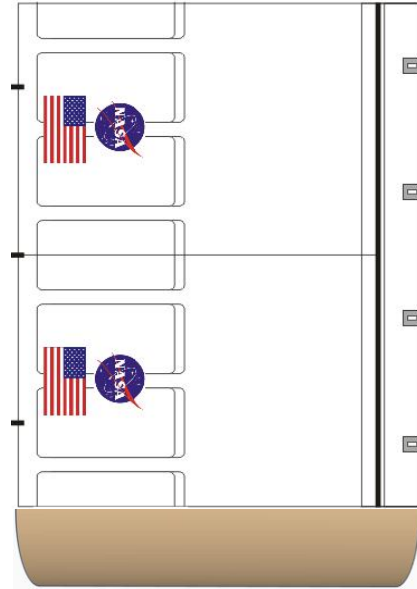
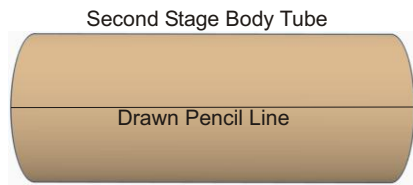

6

Follow the same steps outlined in number 5 above to attach the two remaining wraps to the first stage body tube. Draw a straight line along the length of the tube then attach the upper and lower body wraps. After the second wrap is completed cut off any remaining wrap that is overhanging the tube with a sharp razor knife.

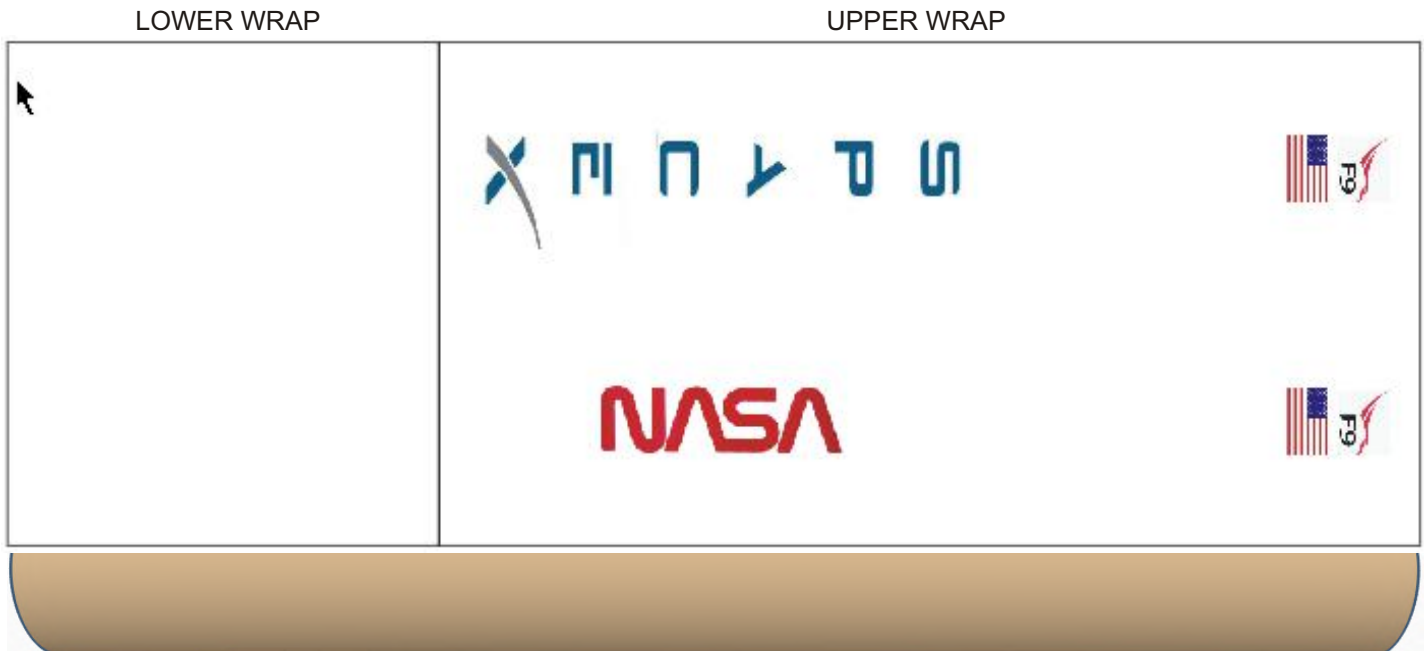

SpaceX Falcon 9 Builders Kit

7

Gather the following parts for assembling the interstage assembly. You'll need the interstage body tube, one of the BT-60 couplers, the supplied length of Kevlar cord, all four sanded grid fins and the fin can to use as a marking guide. Place the fin can into one end of the interstage tube and mark the end of the tube nearest the can where each fin slot is located. Use a pencil and mark a line about an inch long on the tube centered on each fin slot. Remove the fin can.

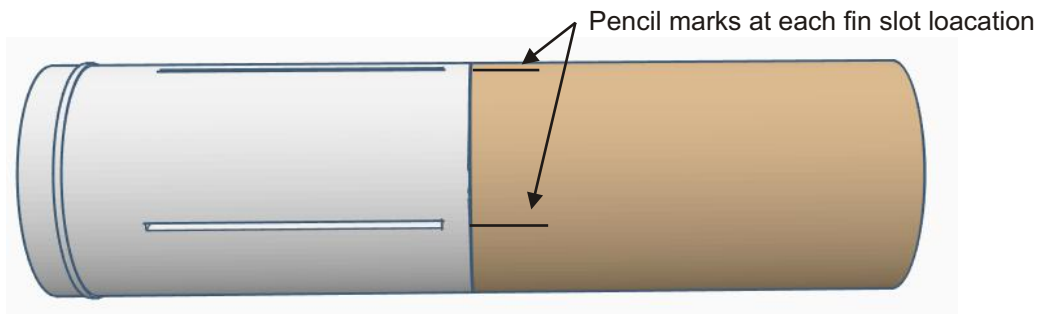

8

Place a pencil mark at the mid-point of the coupler. Tie the end of the length of Kevlar cord around the coupler tube as shown. Place a drop of super glue on the double knot that you tied to secure it in place. Wipe a generous amount of white glue into the inside edge of the interstage and insert the coupler to the mid-point mark.

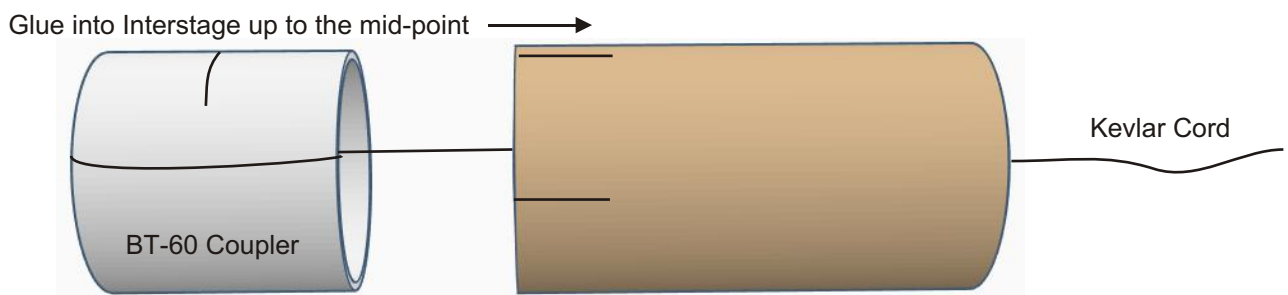

9

After the glue has dried the grid fins can be attached. Using a very small drill bit drill a few holes into the interstage and coupler at the attachment point for each grid fin. Only the portion of the grid fin that comes in contact with the BT-60 interstage tube is glued. Either use epoxy or super glue gel to attach the grid fins. Each fin should be aligned as shown below.

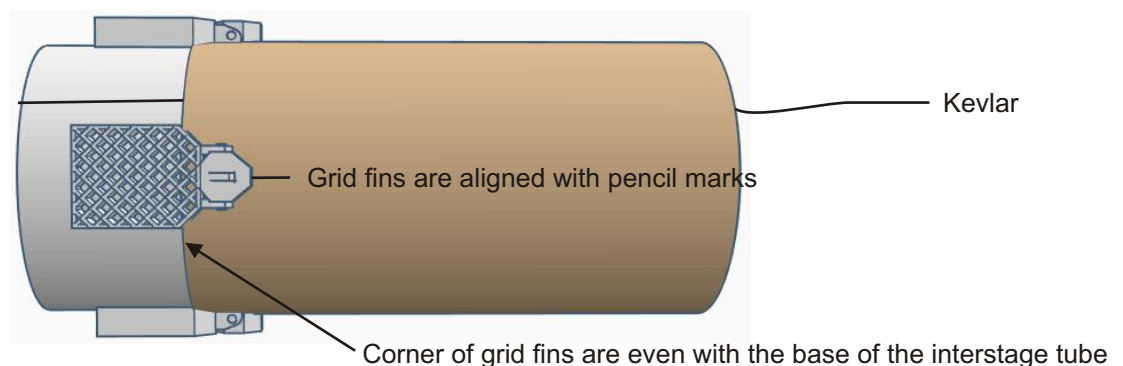

SpaceX Falcon 9 Builders Kit

10

When the interstage and grid fins are dry insert a scrap piece of BT-60 carefully onto the couper and under the grid fins. Paint the interstage with grid fins along with the top side of the landing legs with three coats of flat black paint. Also paint the top sides of the four longer pieces of body conduit flat black. When dry remove the scrap section of BT-60 from the coupler.

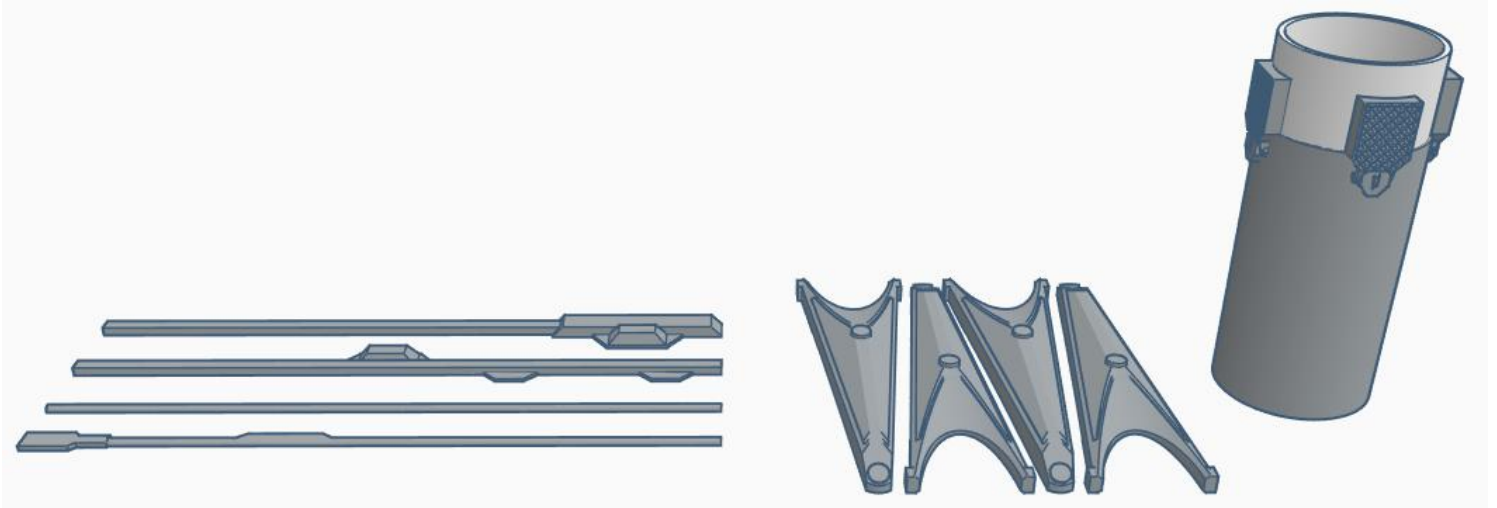

11

Gather the following parts in order to assemble the motor/fin can assembly. You'll need the fin can, the section of BT-50 motor tube, the 24mm motor block and the two part motor retaininer with Merlin engines. Start by gluing the male threaded motor retainer flush to the end of the motor tube. Sand the inside of the part if needed prior to gluing. Determine if you want to use only short 24mm motors or long motors. Using the appropriate sized spent motor casing apply white glue to the inside of the BT-50 at the approximate location for the motor block using a dowel stick. Then using the spent motor casing quickly push the motor block into the tube and glue until only 5mm of the motor extends past the end of the motor tube. Quickly remove the casing before it becomes accidentally glued in place. Set the motor tube on it's top end so that if any glue drips down and dries it will not interfere with loading the rocket motor.

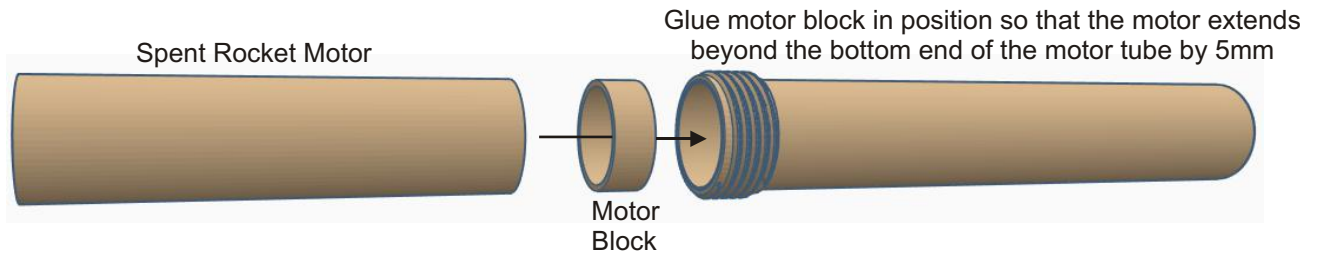

12

When the assembly is dry, test fit the part into the fin can. Sand if needed. Proceed to glue the motor tube into the fin can making sure to seat the tube as far as possible into the fin can.

Glue into fin can seating the tube until it stops against the stops in the fin can.

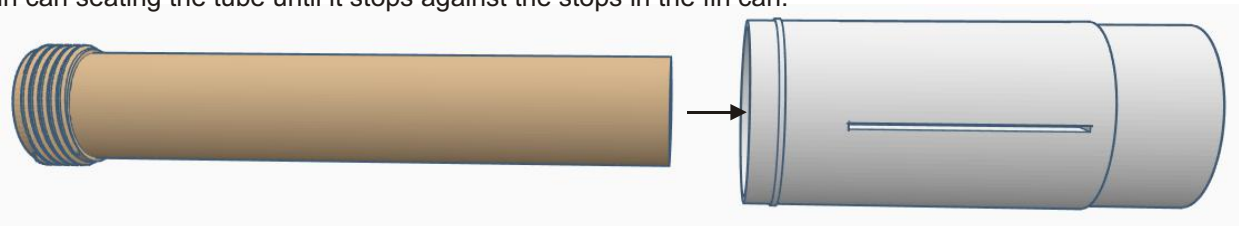

SpaceX Falcon 9 Builders Kit

13

Install the fin can into the first stage body tube. Make sure to align one of the fin slots in the fin can to the seam in the body wrap decal. This will insure the correct alignment of the landing legs and grid fins to the decals. Use epoxy or super glue gel to glue the fin can in place. When dry, draw a light pencil line on the body wrap decal 180 degrees opposite to the seam line in the decal. Make sure that this line is centered on the fin slot that is 180 degrees opposite the fin slot aligned with the wrap seam.

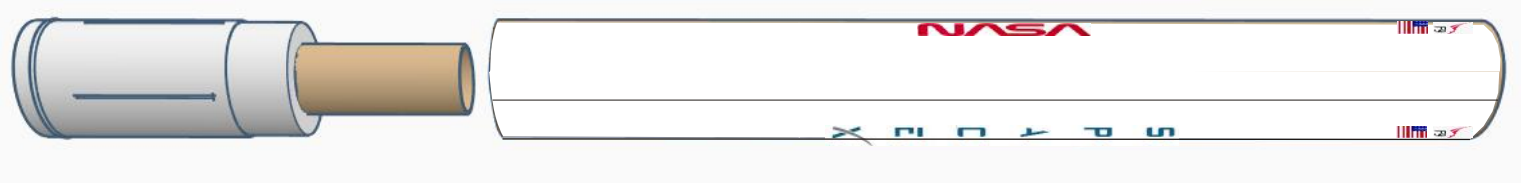

We recommend leaving the fin can unpainted to help the secure gluing of the landing legs!



14

Attach the landing legs to the fin can and the bottom of the first stage body tube. We used super glue gel that was spread evenly over the base of each leg with cheap disposable dollar store paint brushes. Align each fin by pressing it's bottom leg points against the alignment ring then pivoting the leg down to the fin can making sure that the leg is centered between the fin slots. Due to the 3D nature of this image the gap between the leg and the back of each fin slot is not clearly visible but it ends up being around about 2 mm.

Landing legs rest against the ring around the fin can

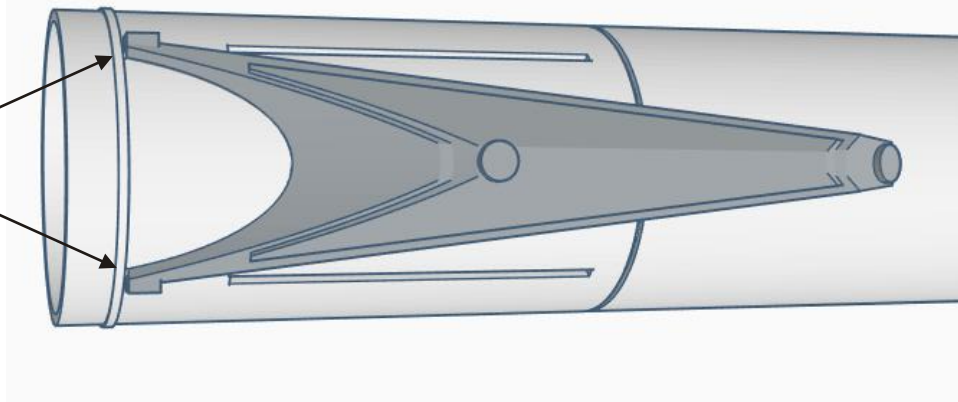

15

When the landing legs are attached and dry the side body conduits can now be added. Each section of the first stage conduit is printed in two pieces due to length. They should be attached as shown (remember they should already be painted flat black). The two wider sections of conduit should be attached over the seam of the body wrap and the narrow sections centered on the pencil line on the opposite side of the vehicle. Again use epoxy or super glue gel brushed on. Attach the top section of each section first then, when dry, the bottom section.

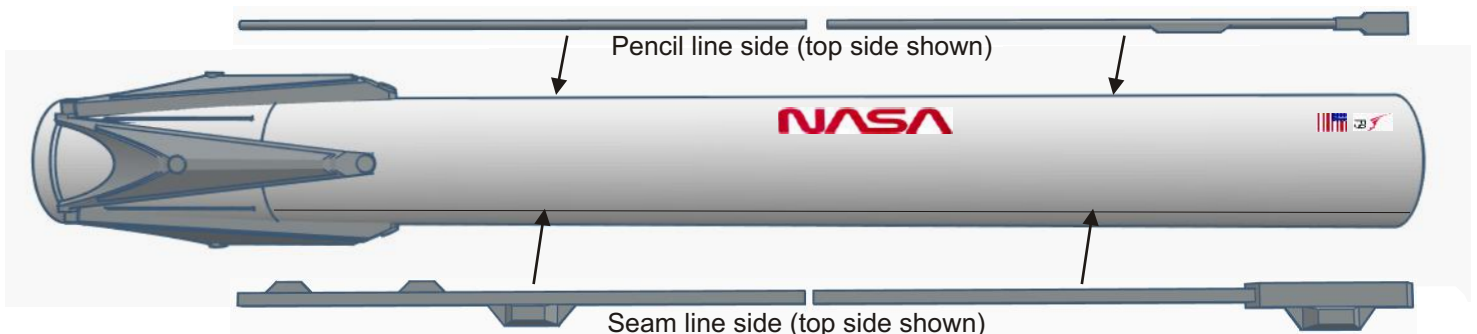

SpaceX Falcon 9 Builders Kit

16

After installation the conduits should look as in the image below.. Please note that the wide sections of the conduits are thin so that when glued they can be bent down a bit to follow the contour of the body tube. Screw on the motor retainer after painting the exterior motor bells and bulkhead flat black. Finally, attach the two launch lugs in the position shown below. Before gluing them in place poke small holes in the body tube with a straight pin under their glue locations for strength.



Launch lug attachment points (against the small body conduit)

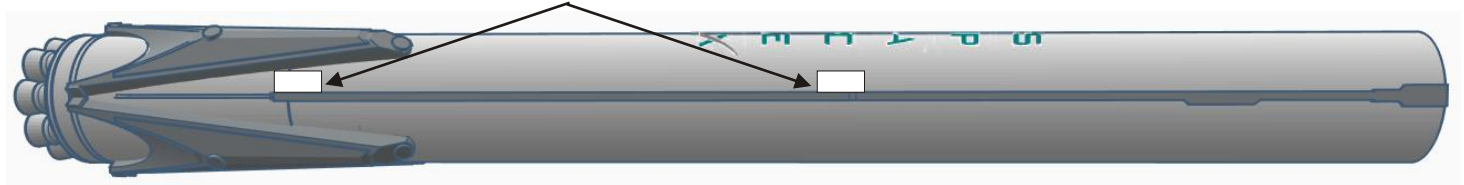

17

Test fit the interstage on the first stage. Glue the interstage in place making sure the grid fins are aligned with the landing legs.

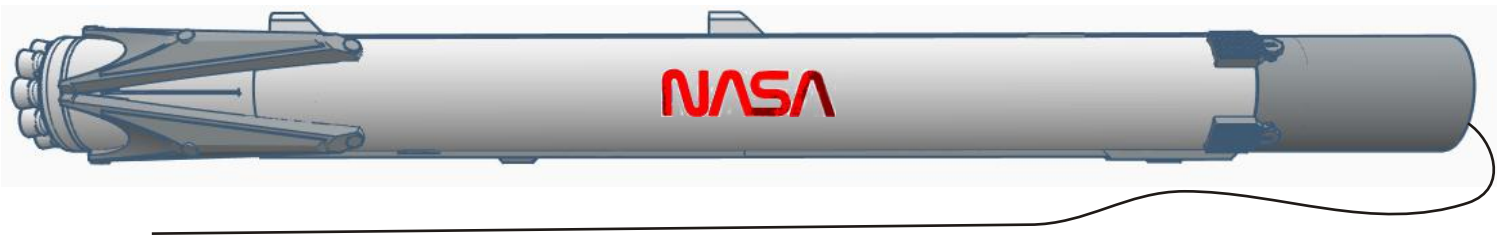

18

Complete the assembly of the second stage. Paint the top side of both short conduit pieces flat white. When dry attach the two conduit sections on either side of the second stage. Again, the wider section of conduit is glued over the wrap seam and the narrower one over the thin line printed on the the opposite side of the wrap.

Printed thin alignment line side

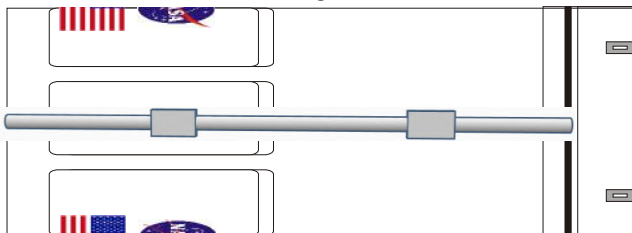

Body wrap seam side

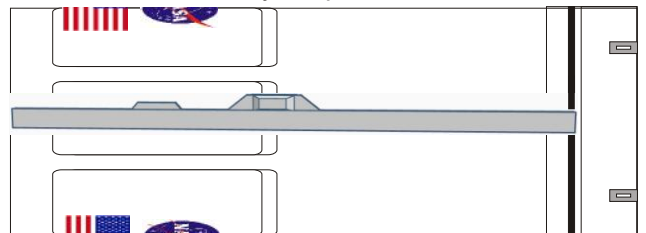

SpaceX Falcon 9 Builders Kit

19

Mark the remaining BT-60 tube coupler at it's mid-point then glue it into the bottom of the second stage as shown. Feed the Kevlar through the second stage then glue the second stage to the rest of the vehicle making sure to line up the thin conduit sides (top and bottom) and the wide conduit sides with the rest of the vehicle.

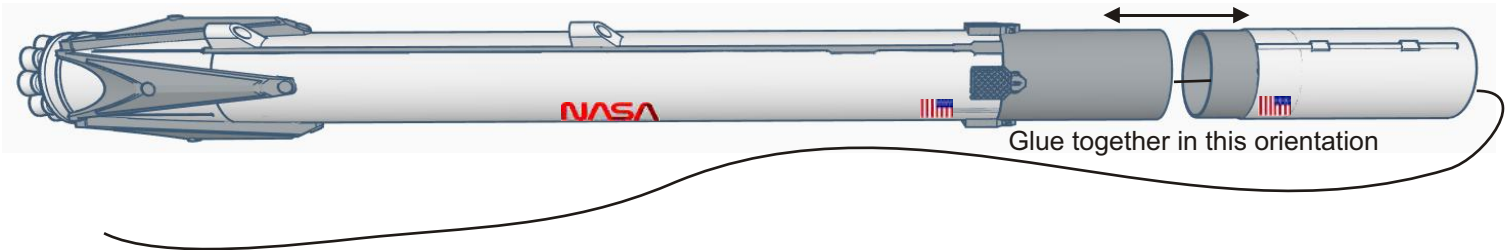

20

Paint the DSLA printed resin capsule flat white. When dry mask off and paint, or cheat and use felt pens, to detail the capsule. When dry test fit the shoulder to the base of the capsule and test fit it into the top of the second stage. If loose apply masking tape around the shoulder to get a good fit (resin prints sometimes don't stay as dimensionally accurate as we would like). **DO NOT GLUE THE SHOULDER TO THE DRAGON UNTIL THE MODEL IS BALANCED FOR THE CORRECT C.G.** Connect your shock cord and 24" parachute to the anchor point at the base of the capsule shoulder along with the Kevlar from the first stage.

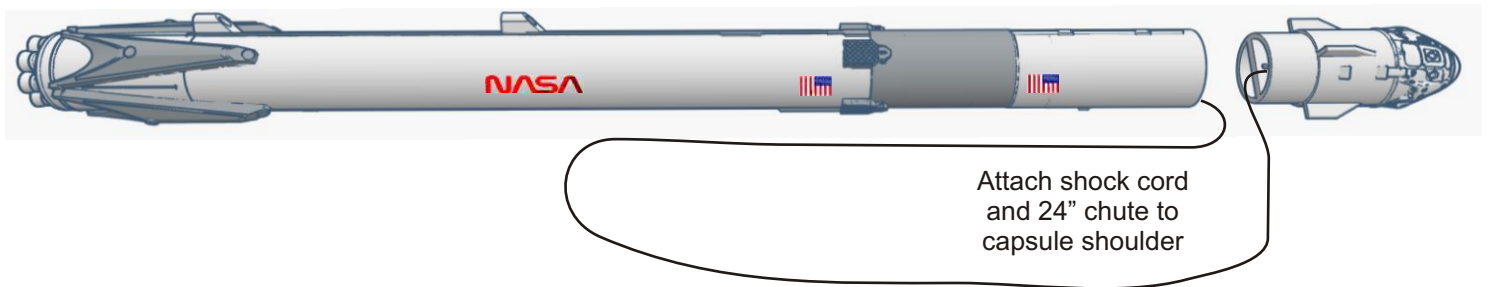

21

The clear fins for flight can be installed either permanently or so that they are removable for display. To make the fins permanent just glue them in place using super glue. If you wish to make them removeable after flight just cut small strips of masking tape 14mm wide by 45mm long and wrap these around the root edge of each fin. This should make each fin a nice pressure fit in it's fin slot. If needed add additional tape until a snug fit is achieved.

Masking tape 14mm x 45mm
folded around the fin edge

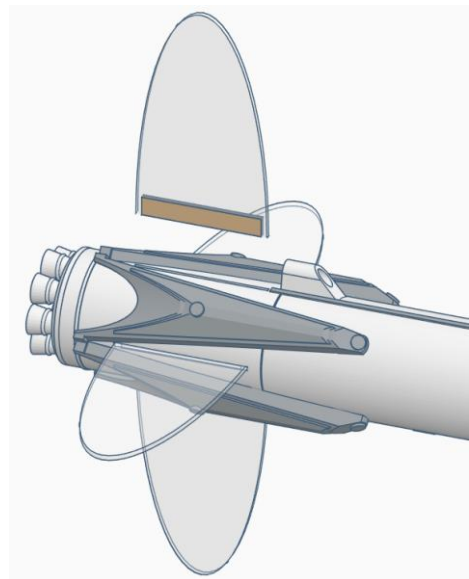
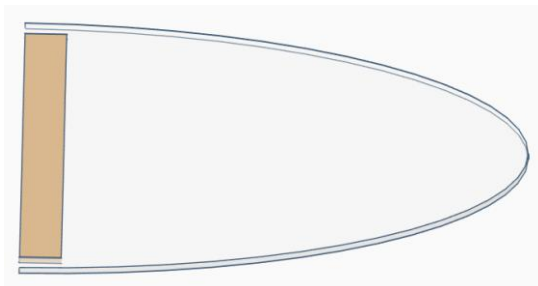

SpaceX Falcon 9 Builders Kit

IMPORTANT!

IMPORTANT!

IMPORTANT!

Put an Estes E12-4 rocket motor in the model, add recovery wadding and the chute. Check the balance point of the model (CG or center of gravity). It should be very close to balancing at the recommended CG point after adding about 1.5 to 1.75 oz of clay in the tip of the nose cone. If the model balances behind the required CG add additional clay to the tip of the nose cone until the CG is correct. Pour a small amount of epoxy over the clay to hold it permanently in position. Glue the shoulder in place then when dry then slide the capsule in position.

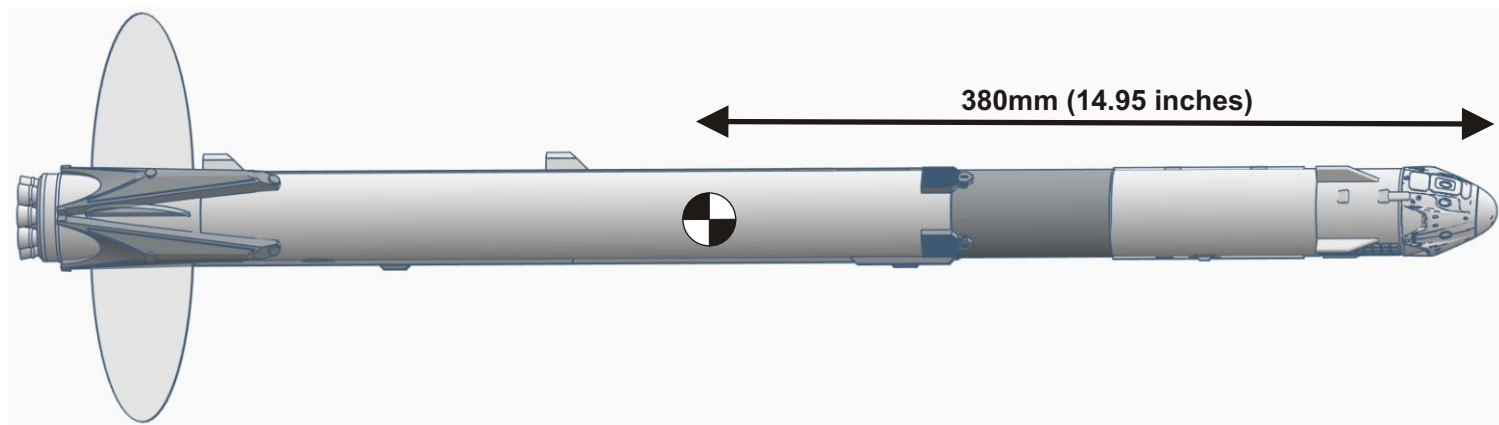

Failure to adjust the models C.G. to the position shown will result in a unstable flight that could injure someone, damage personal property and damage or destroy your model.

RECOMMENDED MOTORS FOR FLIGHT:

Estes D12-3.....	360 Feet
Estes E12-6.....	758 Feet
Aerotech E20-7.....	1118 Feet
Aerotech F11W-8.....	1317 Feet
Aerotech F32T-8.....	1764 Feet

Flight Prep:

- 1) Use recovery wadding and carefully pack your parachute.
- 2) Use an Estes E12-6 motor for your first flight.
- 3) Carefully fit the motor in place inside the motor mount tube then screw on the motor retainer. Insert an electric igniter per the motor manufacturer's instructions.
- 4) Load the model on a launcher with a 3/16th inch launch rod.
- 5) Attach the ignitor leads to the ignitor,
- 6) Check the sky for aircraft and the range for people.
- 7) When all is clear count down 5..4..3..2..1..Launch!

Use a software program such as ROCKSIM to model the rockets flight if higher performance motors are used. Please follow all local laws and the NAR Model Rocketry Safety Code when flying this model. Fly safe and have fun!

SpaceX Falcon 9 Builders Kit

