



**2015-2020 Ford F-150 BIG
MOUTH “LIT KIT” Quad and
Dual Intake Installation Guide**

VELOSSA TECH

2015-2017 F150 BIG MOUTH Lit Kit - Contents

Please review this document before attempting installation.

You will need basic hand tools and about 2 hours of installation time.

Please review the table below and make sure you have received the kit contents.



Kit Contents (QUAD Kit)	Qty
M5 x 14mm Button Head Screw	12
Drill Templates (A+B+C+D)	4
M5 x 25mm Cap Screw	2
M3 x 60mm Cap Screw	1
AGS Simulator Spline Shaft "D"	1
AGS Simulator Spline Shaft "P"	1
Diode Dynamics RGBW Controller	1
Positive Cable w/ In-Line Fuse	1
Power Cable w/ Pigtail Connector	1
Switch	1
Switch Ground Cable w/ Pigtail	1
Cable Clips	4
8" Zip Ties	8
Assembled LIT KIT BIG MOUTH	1



Kit Contents (DUAL Kit)	Qty
M5 x 14mm Button Head Screw	8
Drill Templates (A+B)	2
M5 x 25mm Cap Screw	2
M3 x 60mm Cap Screw	1
AGS Simulator Spline Shaft "D"	1
AGS Simulator Spline Shaft "P"	1
Diode Dynamics RGBW Controller	1
Positive Cable w/ In-Line Fuse	1
Power Cable w/ Pigtail Connector	1
Switch	1
Switch Ground Cable w/ Pigtail	1
Cable Clips	4
8" Zip Ties	8
Assembled LIT KIT BIG MOUTH	1



VELOSSA TECH

2018-2020 F150 BIG MOUTH Lit Kit - Contents

Please review this document before attempting installation.

You will need basic hand tools and about 2 hours of installation time.

Please review the table below and make sure you have received the kit contents.



Kit Contents (QUAD Kit)	Qty
M5 x 14mm Button Head Screw	12
Drill Templates (A+B+C+D)	4
M5 x 25mm Cap Screw	2
M3 x 60mm Cap Screw	1
AGS Simulator Spline Shaft "D"	1
AGS Simulator Spline Shaft "P"	1
Diode Dynamics RGBW Controller	1
Positive Cable w/ In-Line Fuse	1
Power Cable w/ Pigtail Connector	1
Switch	1
Switch Ground Cable w/ Pigtail	1
Cable Clips	4
8" Zip Ties	8
Assembled LIT KIT BIG MOUTH	1



Kit Contents (DUAL Kit)	Qty
M5 x 14mm Button Head Screw	8
Drill Templates (A+B)	2
M5 x 25mm Cap Screw	2
M3 x 60mm Cap Screw	1
AGS Simulator Spline Shaft "D"	1
AGS Simulator Spline Shaft "P"	1
Diode Dynamics RGBW Controller	1
Positive Cable w/ In-Line Fuse	1
Power Cable w/ Pigtail Connector	1
Switch	1
Switch Ground Cable w/ Pigtail	1
Cable Clips	4
8" Zip Ties	8
Assembled LIT KIT BIG MOUTH	1



VELOSSA TECH

Stock Components Removal

Use Google or online forums to search for best practices when removing the front bumper.

2015-2017 Cowl Templates

After removal of the grille/cowl assembly, you will need to use the supplied templates to drill $\frac{1}{4}$ " holes in the locations shown. (Dual kits only have two templates).

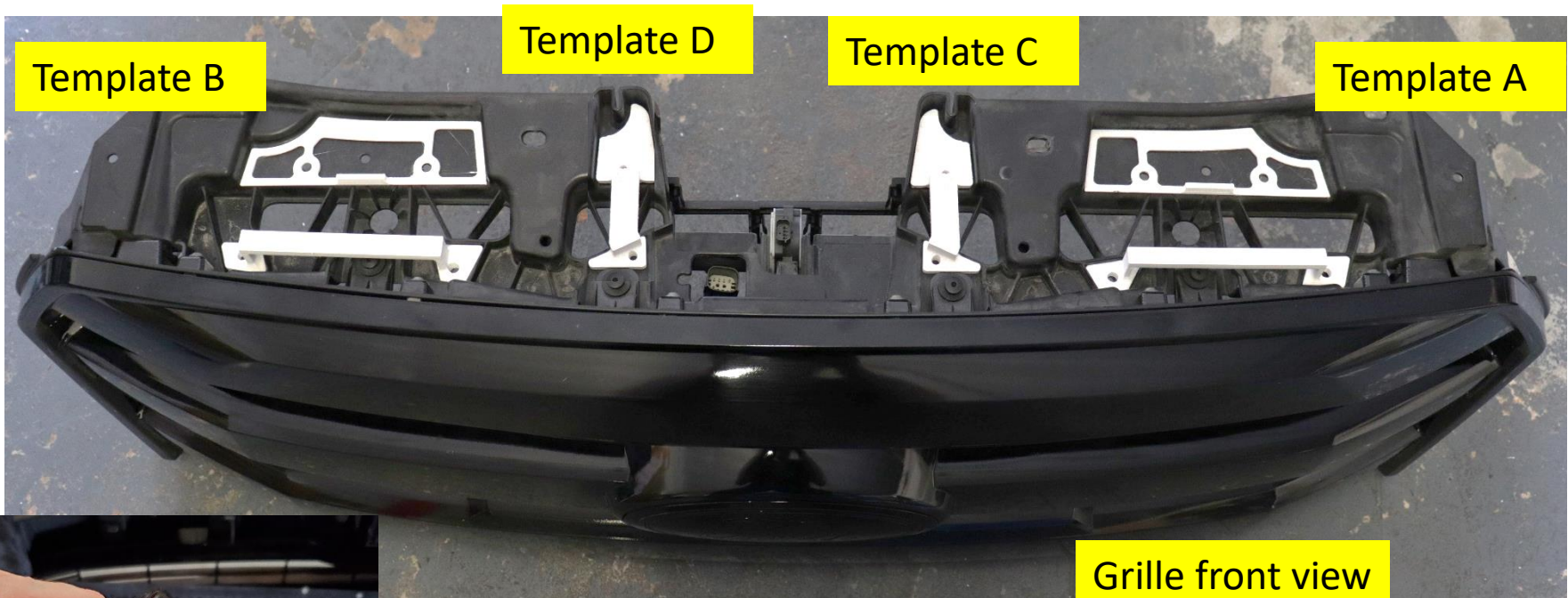

Letter designations on the BIG MOUTH ducts.

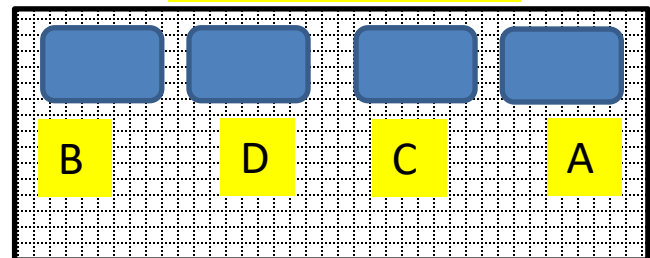

2018-2020 Cowl Templates

After removal of the grille/cowl assembly, you will need to use the supplied templates to drill $\frac{1}{4}$ " holes in the locations shown. (Dual kits only have two templates).

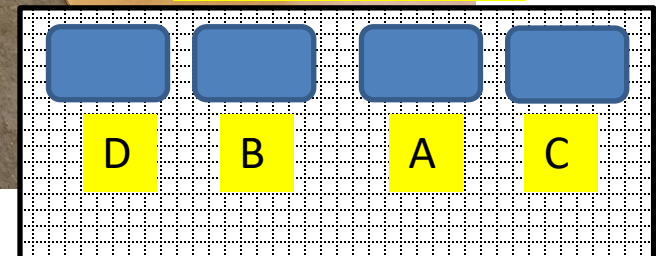
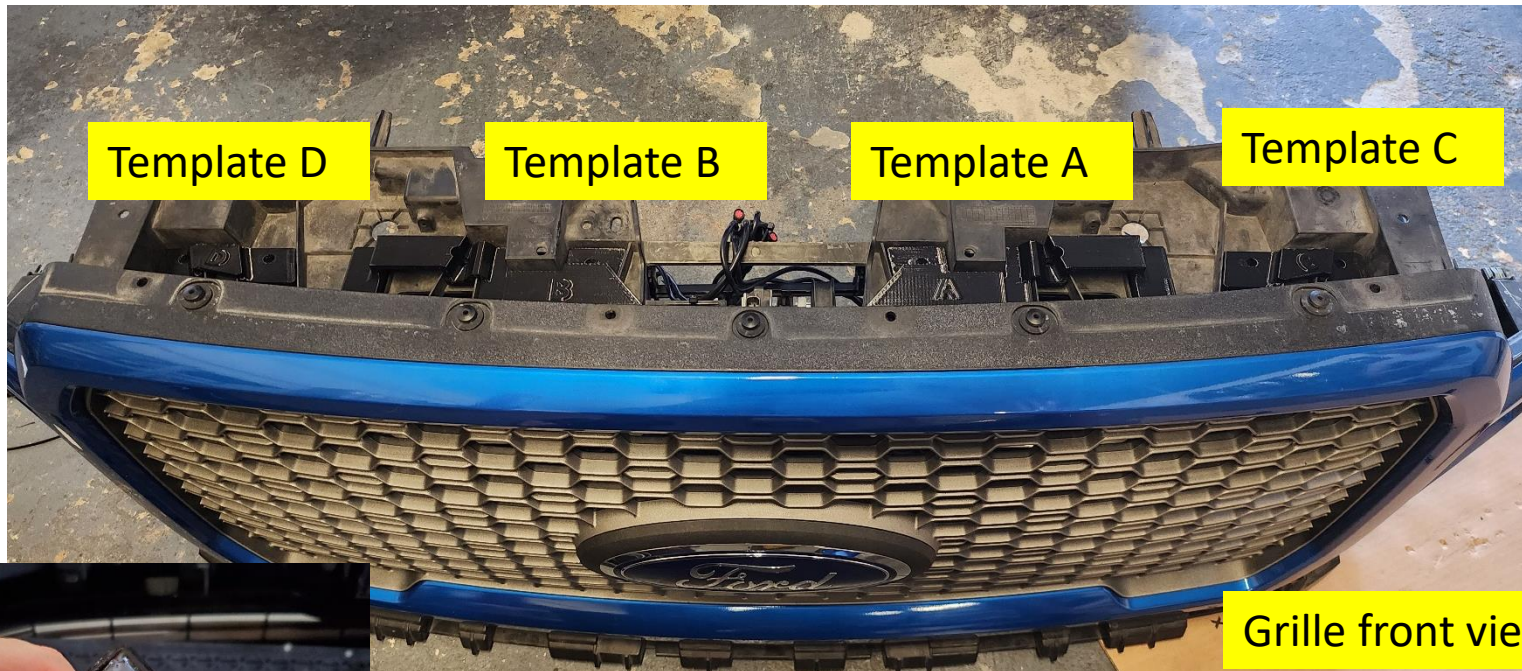

Stock Components Removal

Remove the top 4 AGS flaps to allow clearance for the BIG MOUTH intakes. You can flex these flaps at their center, and then bend them outward to unhook the engagement pegs. See below.



AGS Simulator

This assembly was engineered and tested to allow the AGS to continue to function, which will prevent a soft code from showing up on the dash for some 13th gen F150 models.

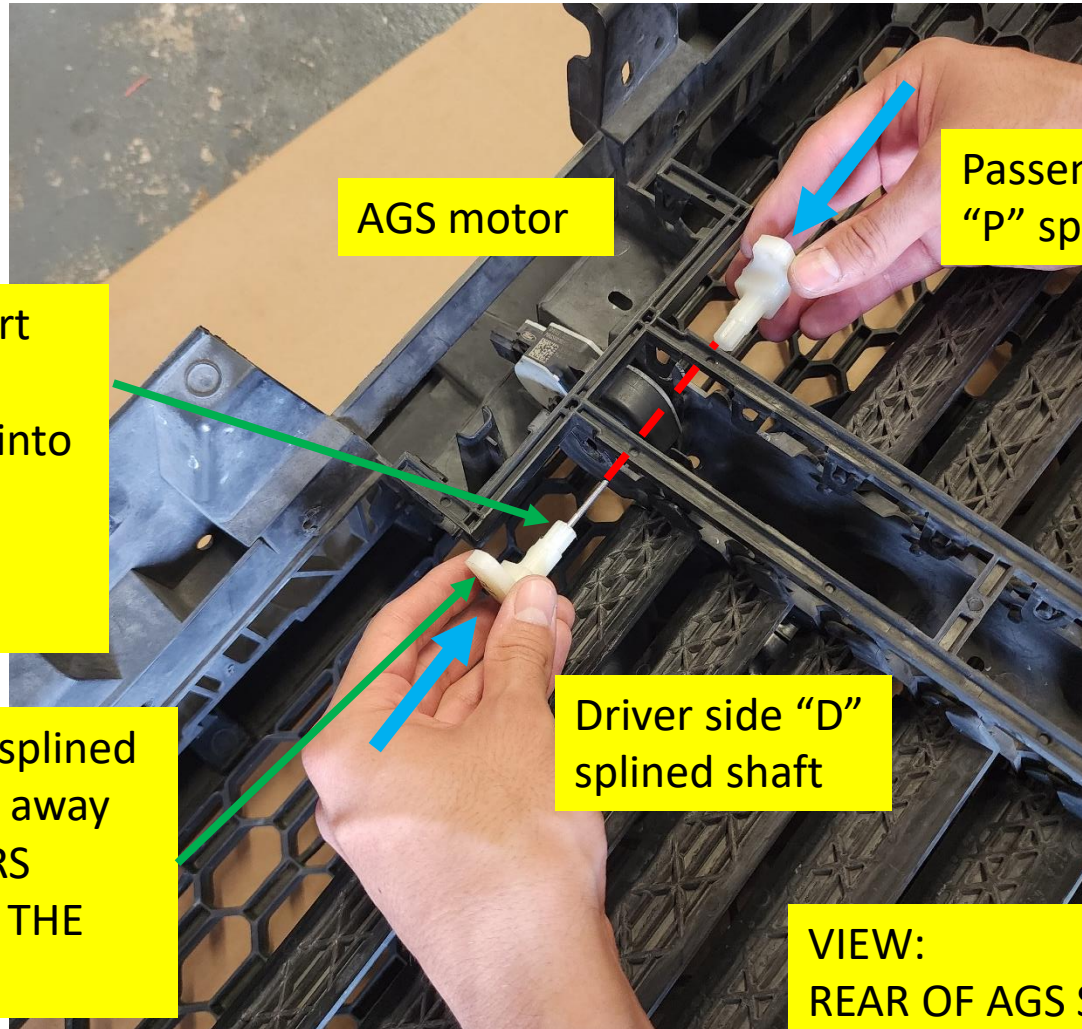

AGS motor

Passenger side
"P" splined shaft

60mm long M3 bolt, insert into the driver side "D" splined shaft and thread into the other splined shafts through the AGS motor, make a sandwich.

Driver side "D"
splined shaft

The 'ear' of the supplied splined shaft should be facing up away from the grille. BOTH EARS SHOULD BE POINTING IN THE SAME DIRECTION.

VIEW:
REAR OF AGS SHUTTERS

VELOSSA TECH

AGS Simulator

Use Allen key to fasten the sandwich together, tighten until snug, do not over-torque.

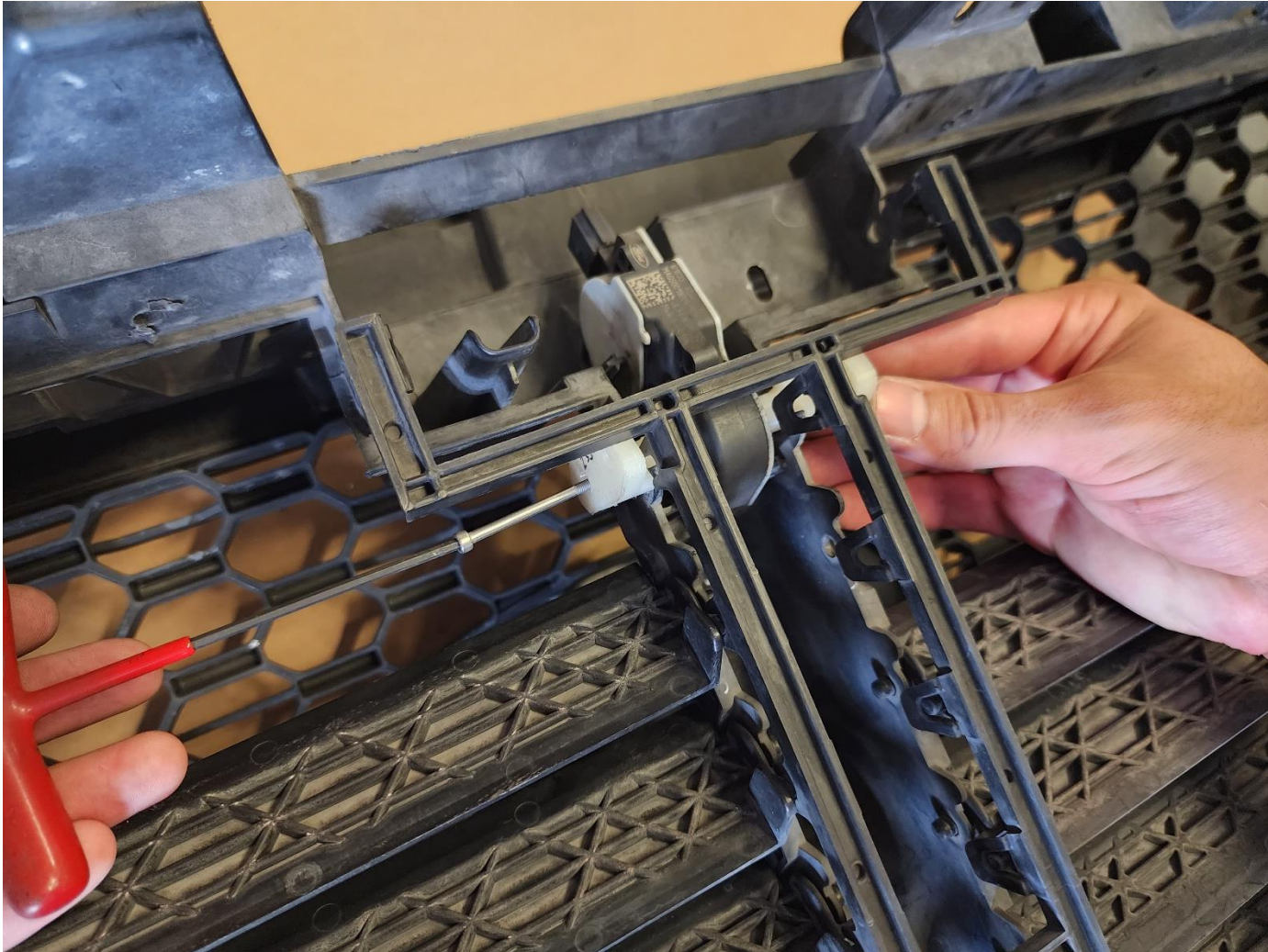

VELOSSA TECH

AGS Simulator

Finalize the assembly by screwing the 5mm bolt into the ears, ensure they bottom out and go through the AGS peg-holes as shown. (You can manually move the AGS to align the peg holes).

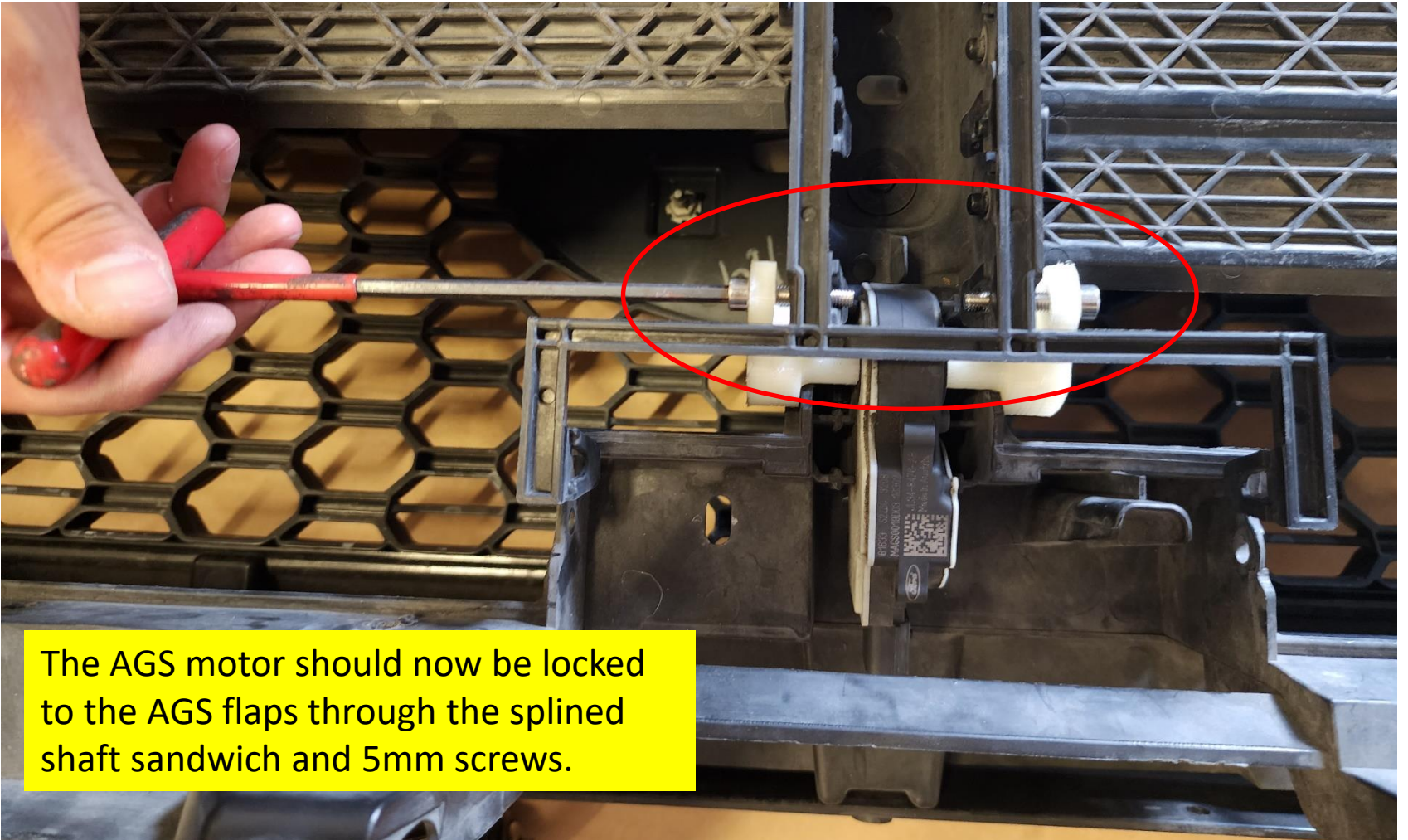

The AGS motor should now be locked to the AGS flaps through the splined shaft sandwich and 5mm screws.

AGS Simulator Testing

Once the AGS Simulator install is complete, temporarily reinstall the bumper (no need to fully fasten yet), **reconnect the AGS motor**, turn your car on and allow the AGS system to perform its initiation cycle. If your flaps successfully open and close without interference, the install is successful and the AGS is fully functional.

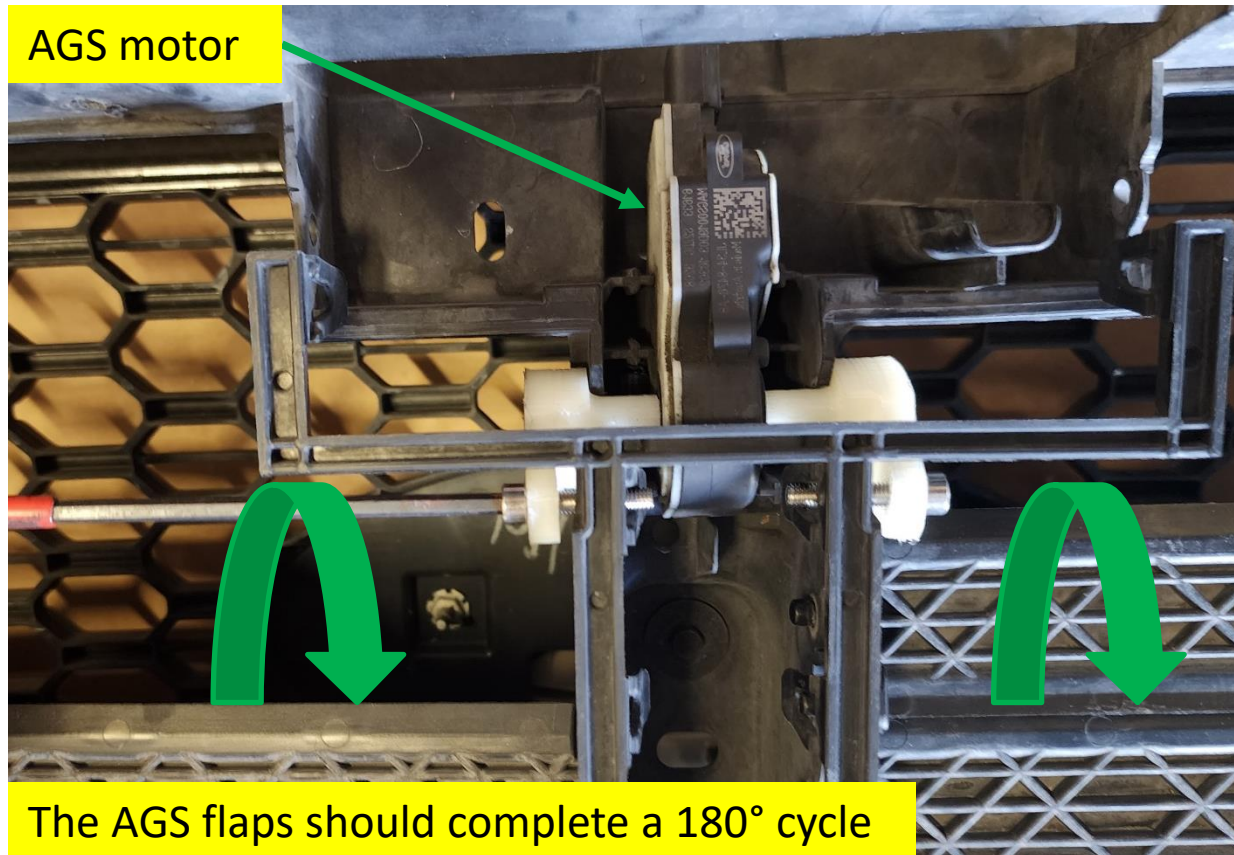

Install BIG MOUTH Ram Air

From underneath the cowl openings, align the BIG MOUTH ram air intakes with the holes drilled, and fasten with supplied button head screws. For a '18-'20 Dual Kit, use the provided spacer on the lowest outer ear to avoid stressing the Big Mouth.

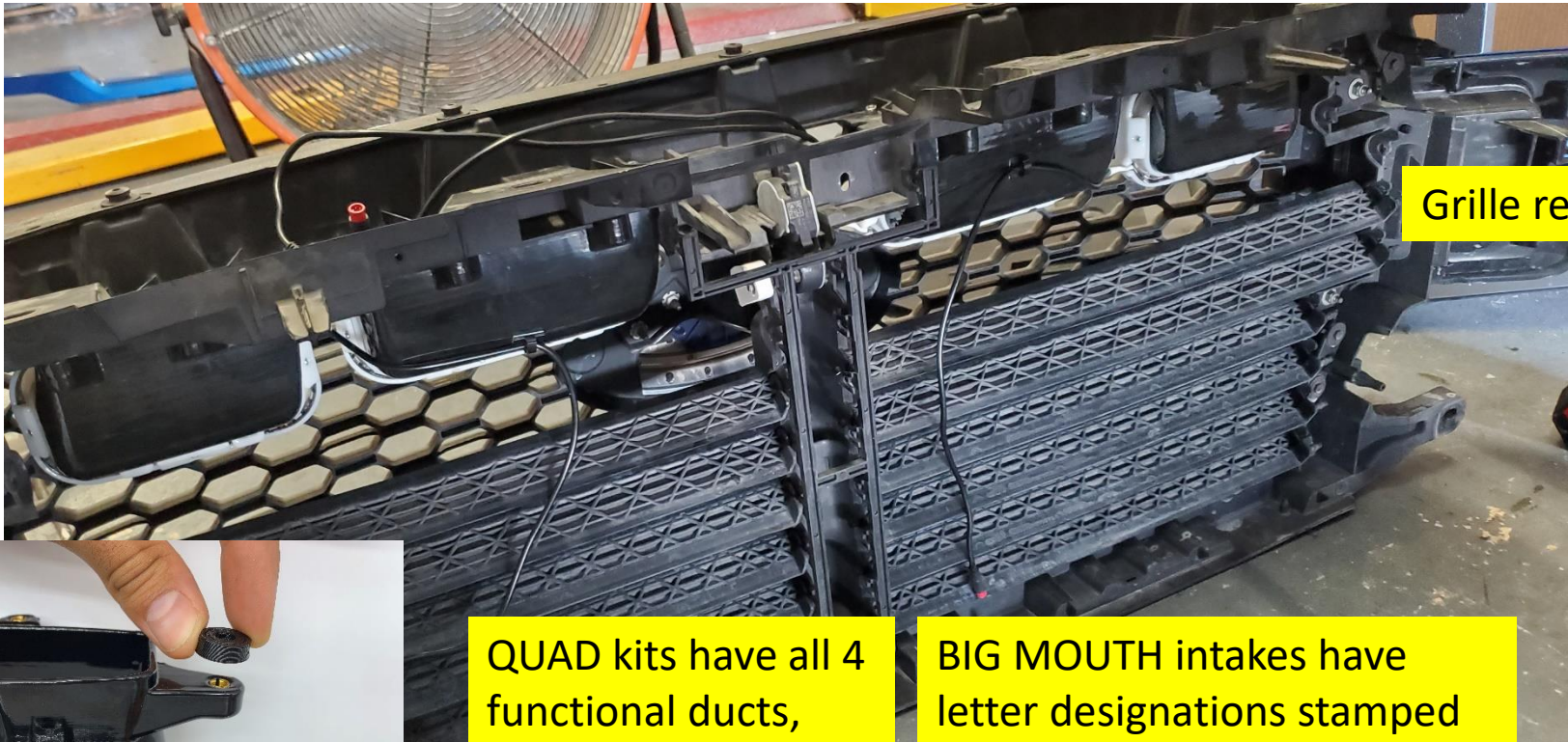

Grille rear view



Spacer for '18-'20 dual kit

QUAD kits have all 4 functional ducts, DUAL kits have ducts A and B only.

BIG MOUTH intakes have letter designations stamped on them. See chart for installation locations.



VELOSSA TECH

Wiring Harness

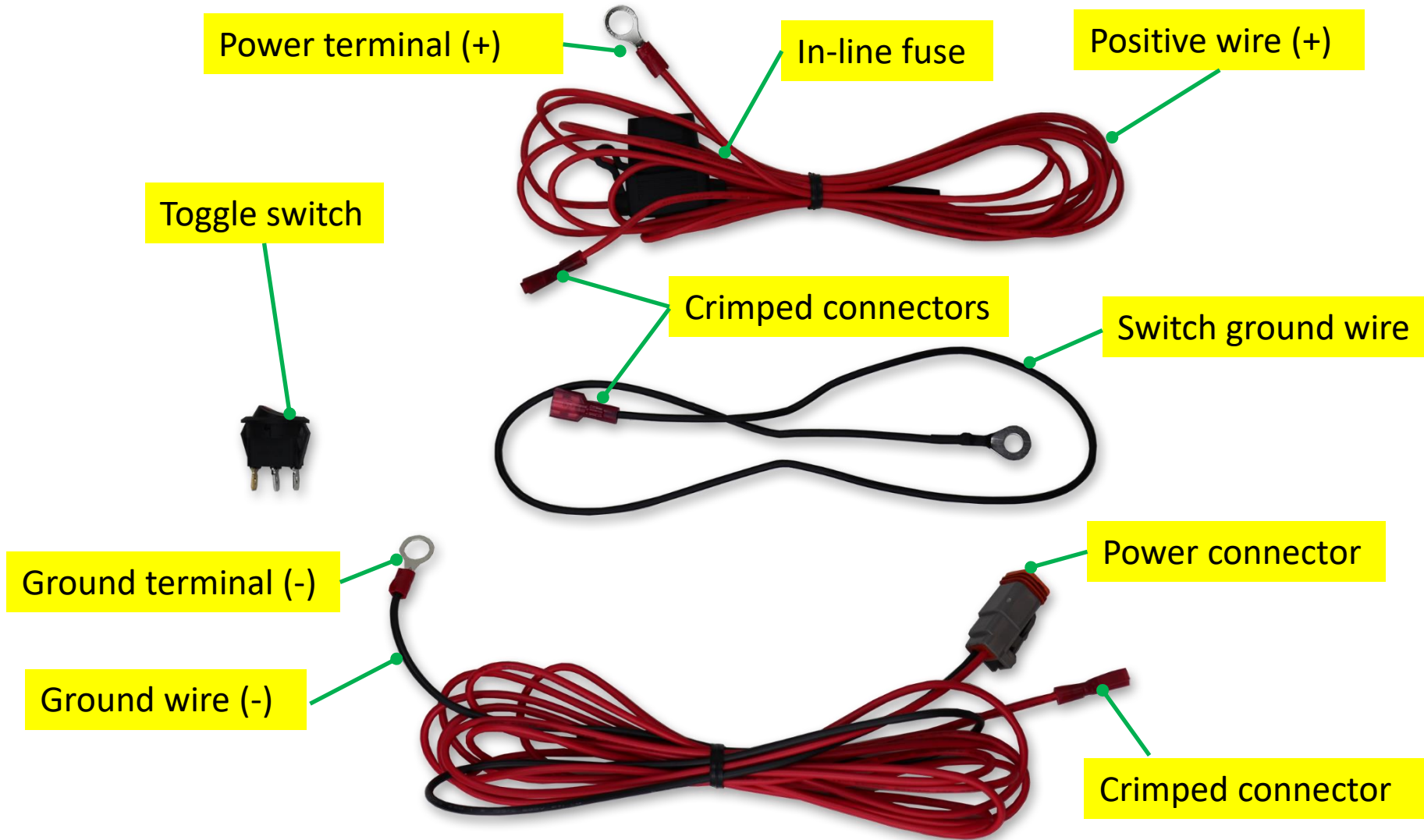



VELOSSA TECH

Wiring Harness Schematic

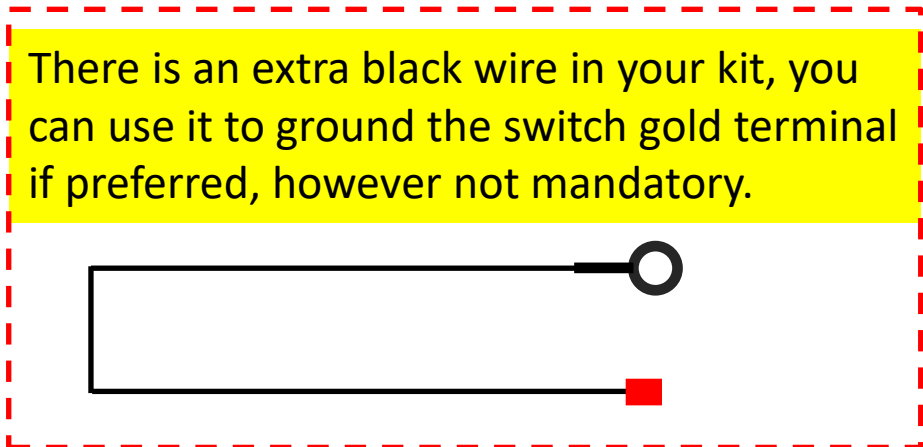
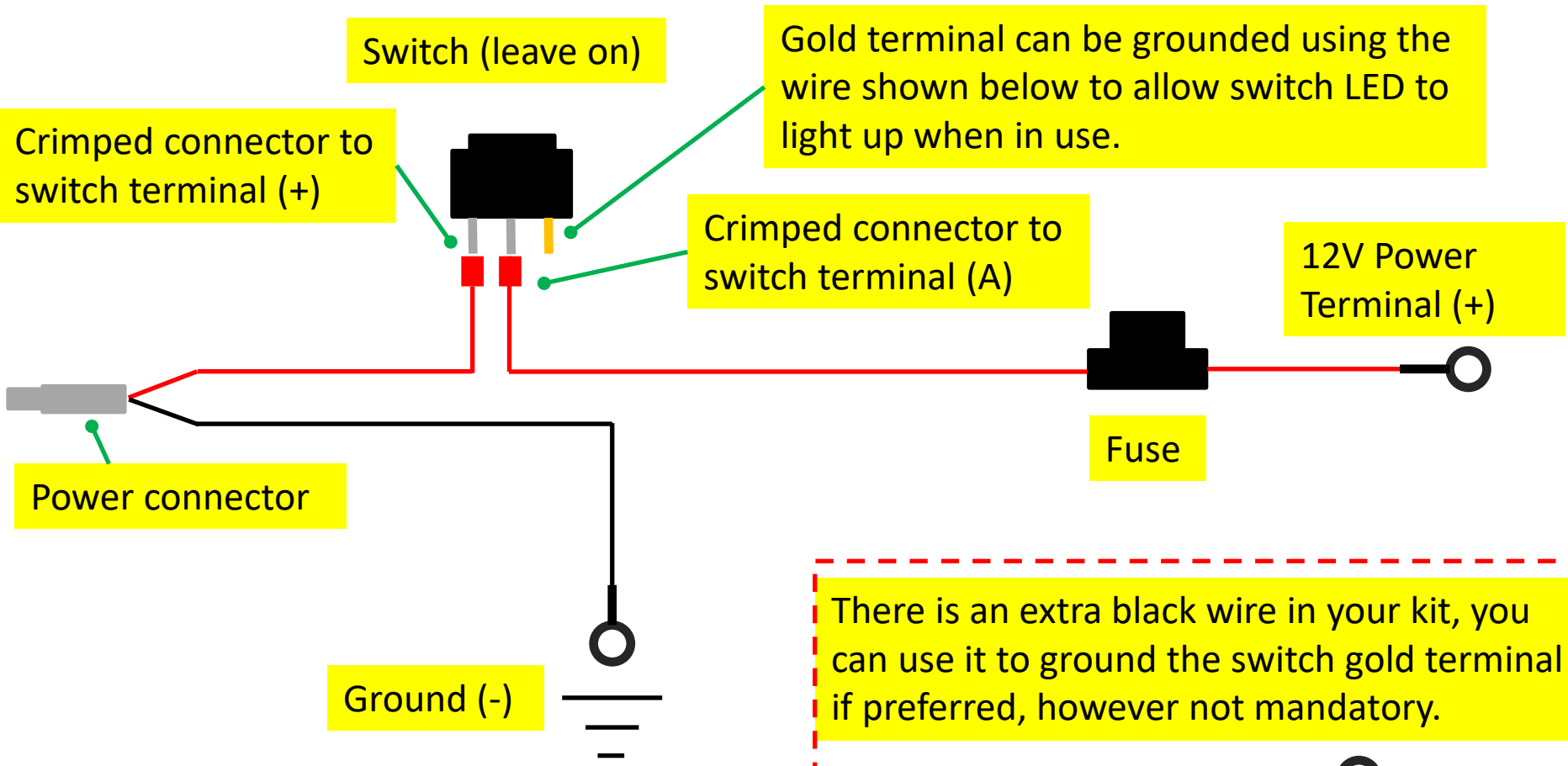

LED Wire Routing

Once the BIG MOUTH intakes are installed, you will need to practice patience and neatness to keep the LED wires from snagging on the AGS assembly. **THIS IS VERY IMPORTANT**. Do not allow the wires to cross through the AGS assembly brackets or flaps, this will cause the flaps to bind and not open or close properly.

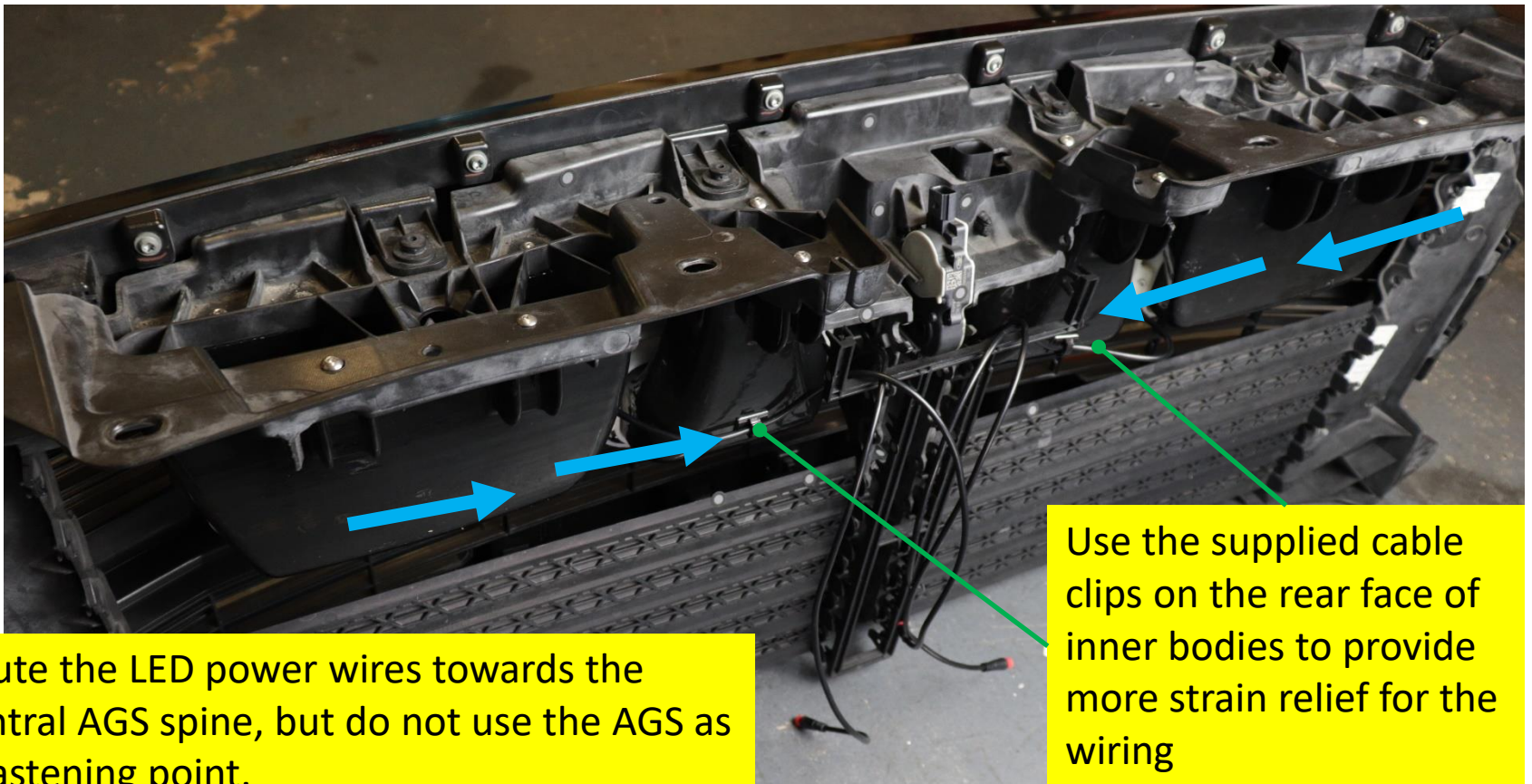

Route the LED power wires towards the central AGS spine, but do not use the AGS as a fastening point.

Use the supplied cable clips on the rear face of inner bodies to provide more strain relief for the wiring

2015-2017 F-150 LED Controller Placement

After the LED power wires are routed towards the center of the AGS assembly, you may mount the controller at the top of the shroud, clean a flat surface with a towel and use the double-sided tape to fasten it firmly in place, ensure the LED power wires are neatly packed together and zip tied AWAY from the AGS and the hood latch.

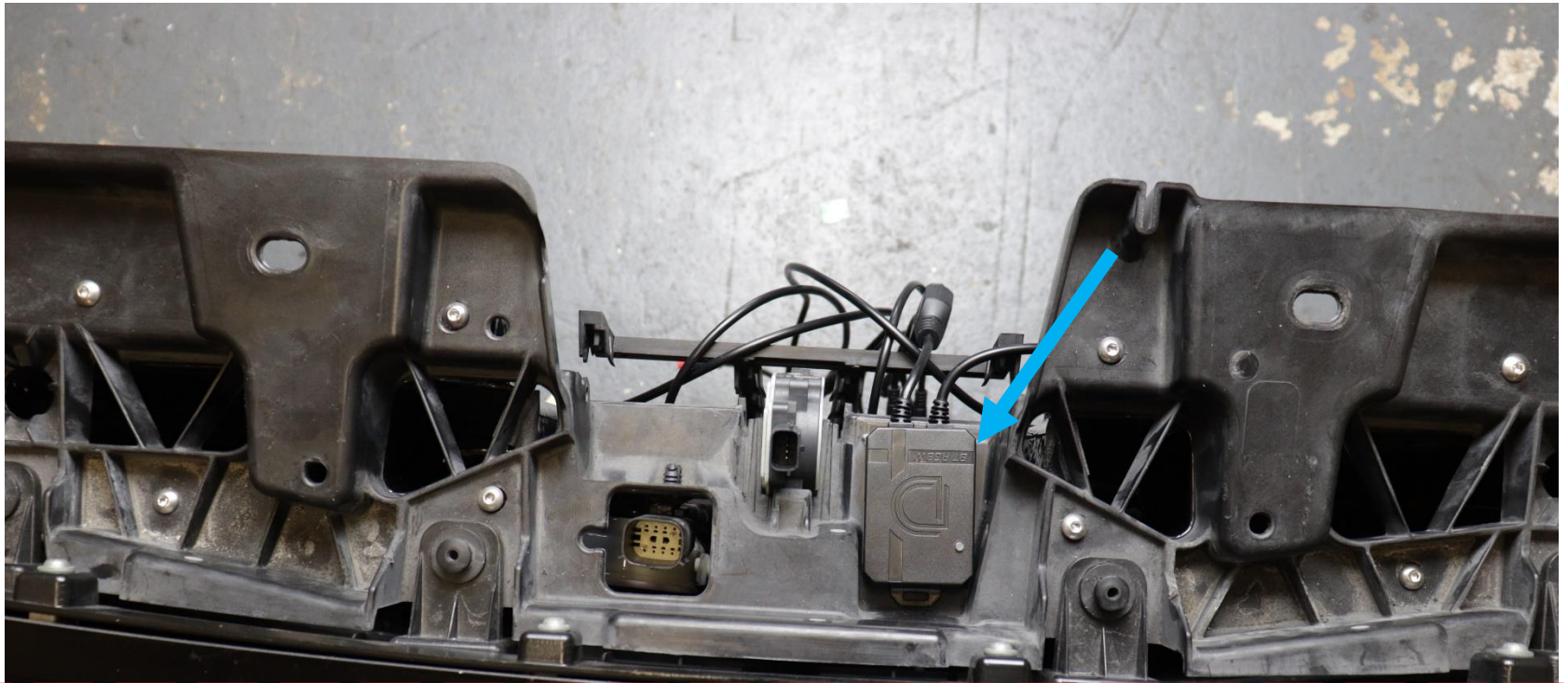

Ensure that the controller is in a suitable location where the LED power wires are not being pulled under tension and the HOOD LATCH IS NOT binding with the wires!

2018-2020 F-150 LED Controller Placement

After the LED power wires are routed towards the center of the AGS assembly, you may mount the controller at the top of the shroud, using a zip tie as shown, ensure the LED power wires are neatly packed together and zip tied AWAY from the AGS and the hood latch.

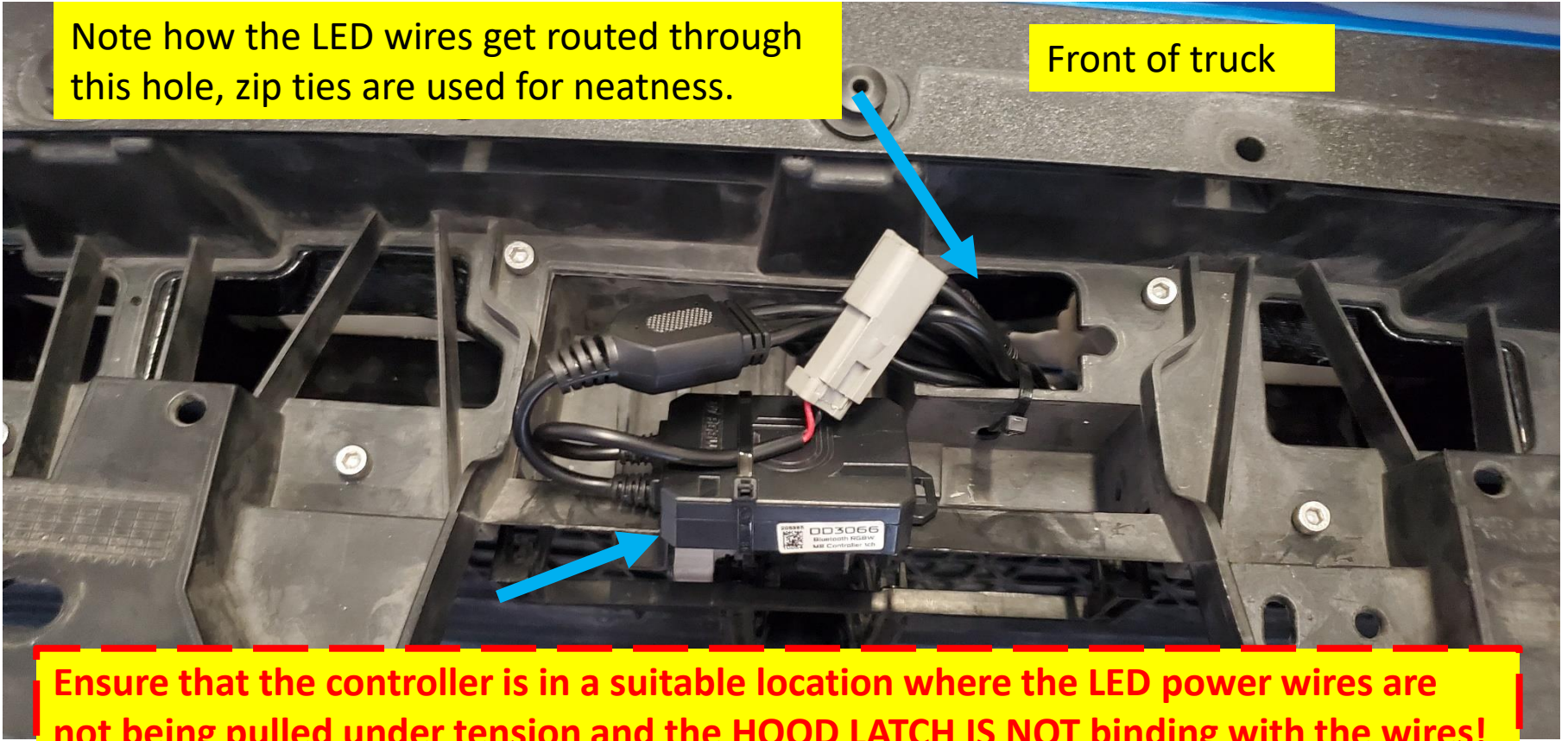

Grounding and Power

Good grounding for the controller is important, bad grounds will lead to controller instability and/or failure. Ensure the ground lugs are tightened down and the surfaces are cleaned prior to grounding. Only use chassis/metal grounds or the battery ground. Route the power harness as shown, use zip ties.

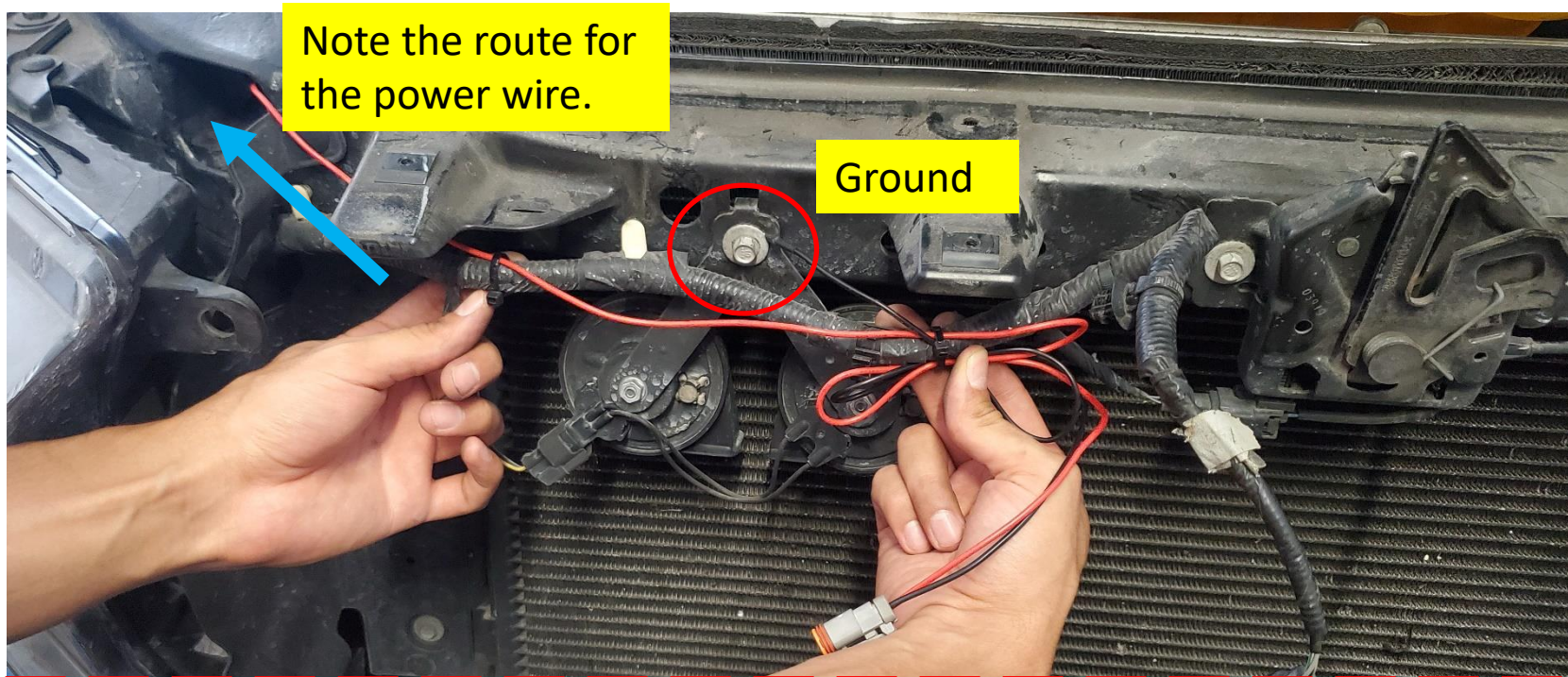

Leave some slack for the pigtail to reach the controller when the bumper is installed

Grounding and Power

Bundle excess wire with zip ties, route power through the switch using the wiring diagram on slide 13, follow it carefully and ensure the wiring is neat.



Grounding and Power

Power can be tapped out of the battery as shown. Use the small ground wire to ground the power switch at the battery negative post. Tuck the wire bundle away.



Grounding and Power

For both 2015-2017 and 2018-2020 F-150s, ensure that the hood latch is clear of any wire snags. Bundle the wires together with slack left, and zip tie the bundles down and AWAY from the hood latch.

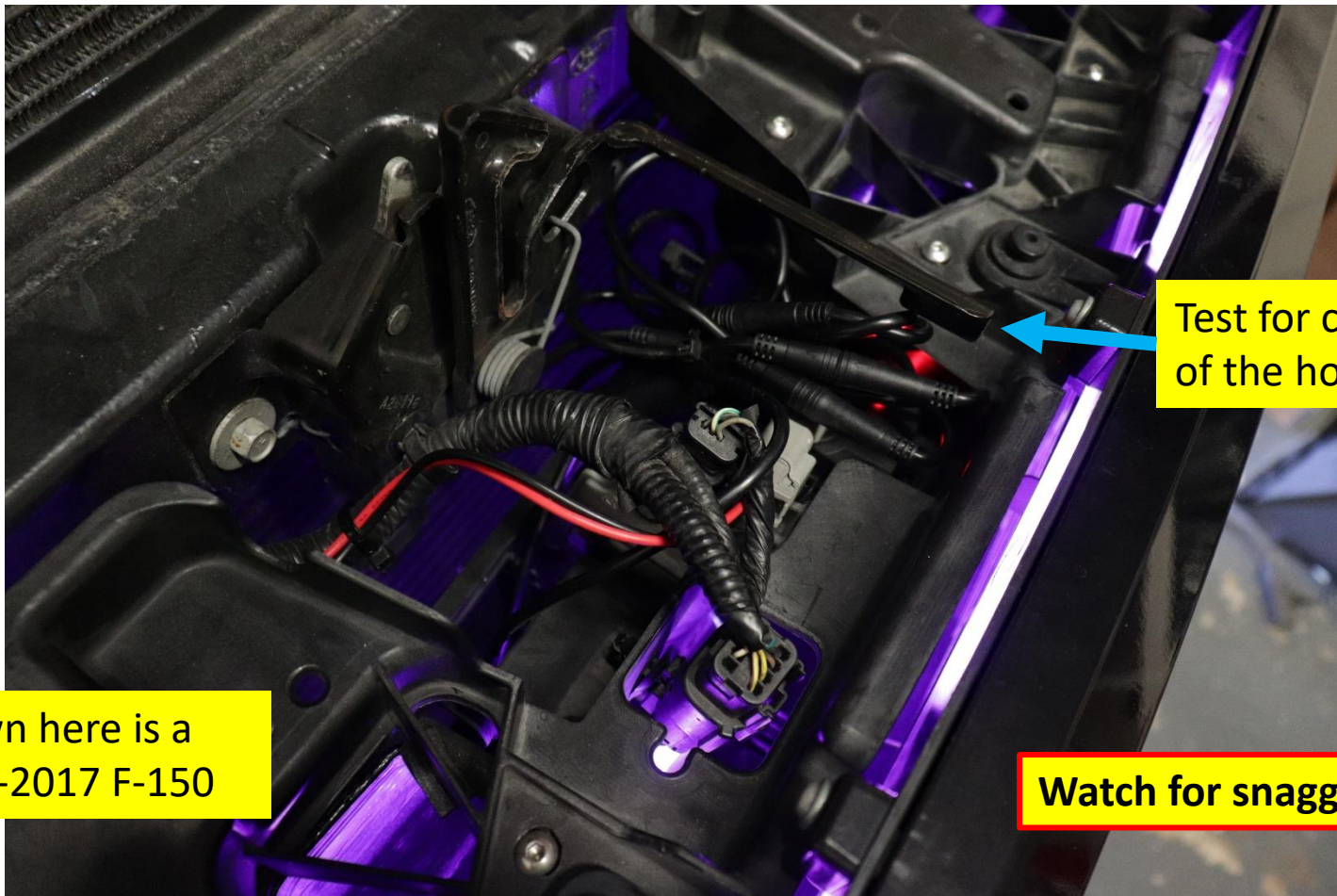

Test for clearance of the hood latch

Shown here is a 2015-2017 F-150

Watch for snagging!!!!

Grounding and Power

For both 2015-2017 and 2018-2020 F-150s, ensure that the hood latch is clear of any wire snags. Bundle the wires together with slack left, and zip tie the bundles down and AWAY from the hood latch.

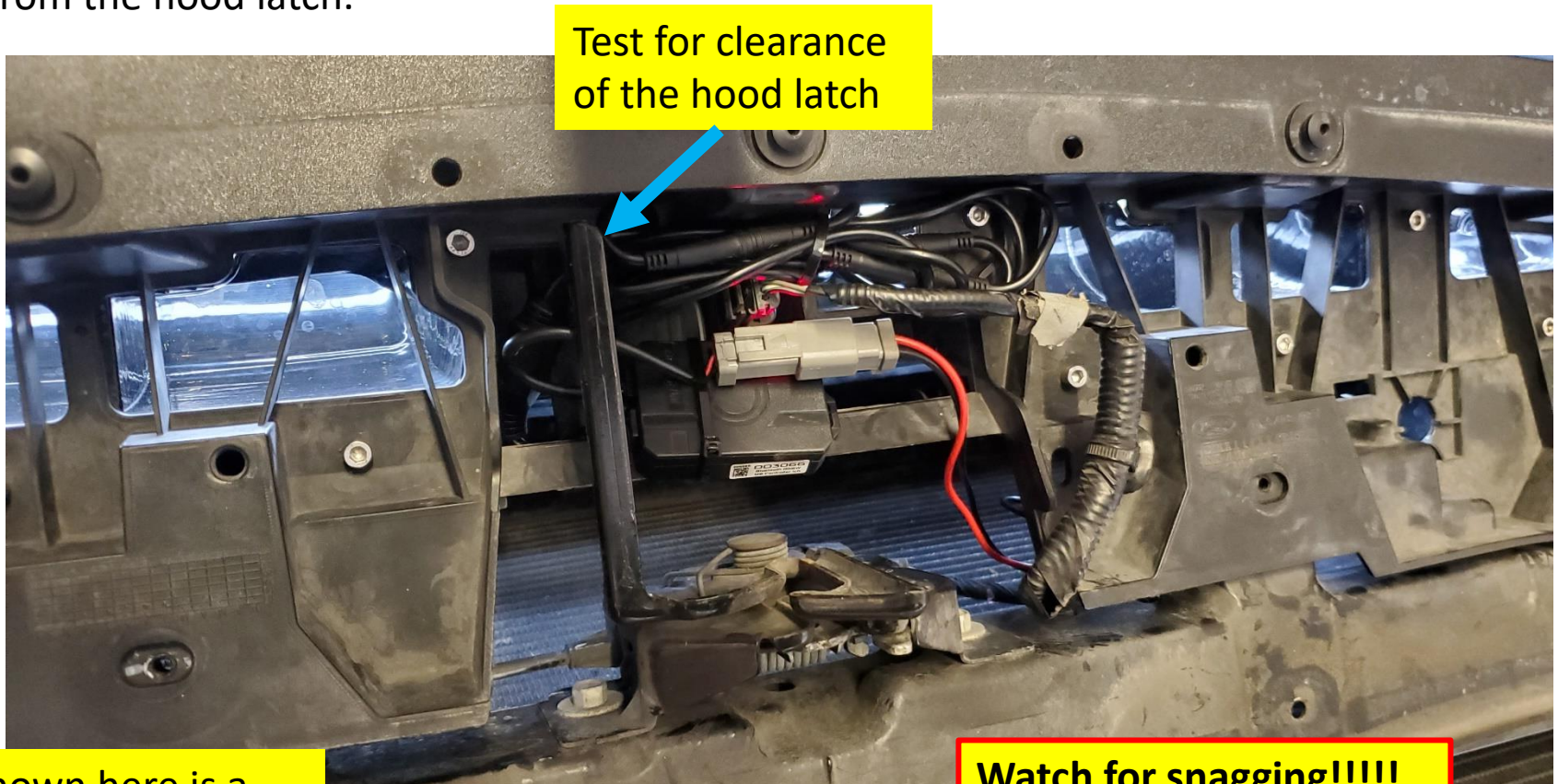

Test for clearance of the hood latch

Shown here is a 2018-2020 F-150

Watch for snagging!!!!

Phone App

Download the Diode Dynamics app and connect via Bluetooth.

How to connect to the app:

1. After installing the app from the app store, open the app on your device.
2. Cycle the power to the Bluetooth controller by unplugging it and plugging it back in or flick the power switch and wait a few seconds, then turn it back on.
3. Wait for the app to detect the controller, it will pop up on the app screen as a Bluetooth controller. If necessary, cycle the power once more to refresh the controller.
4. Once the controller shows up on the app, click it and connect. You have 30 seconds to select the controller once it shows up on the app. After 30 second you will need to refresh again to detect the controller again.
5. Note that if you mounted your controller behind a lot of metal components, this may degrade the signal and range.



VELOSSA TECH

Finalize

You can make an adjustment to the BIG MOUTHS to ensure they are level. Place bumper on the vehicle however do not fasten it yet, inspect visually for alignment and level of your BIG MOUTH intakes. If you need more adjustment, go back and drill bigger holes in the shroud to allow play room, then tighten as needed. You may add shims between the cowl shroud and the BIG MOUTH fastening points to help with leveling for your particular vehicle.

