



**2017-2018 Hyundai Elantra Sport BIG MOUTH
LIT KIT Ram Air Intake Installation Guide**



Kit Contents

Please review this document before attempting installation.

You will need basic hand tools and about 2 hours of installation time.

Please review the table below and make sure you have received the kit contents.

VELOSSA TECH

Kit Contents – Full Lit kit

Please review this document before attempting installation.

You will need basic hand tools and about 2 hours of installation time.

Please review the table below and make sure you have received the kit contents.

Kit Contents	Qty
M6 x 90mm Cap Screw	1
M6 x 100mm Cap Screw	1
M6 Small Washer	4
M6 Lock Nuts	2
Diode Dynamics RGBW Controller	1
Positive Cable w/ In-Line Fuse	1
Power Cable w/ Pigtail Connector	1
Switch	1
Switch Ground Cable w/ Pigtail Connector	1
8" Zip Ties	5
M6 x 12mm Cap Screw	1
M6 Lock Nut	1
Assembled LIT KIT BIG MOUTH	1



Kit Contents (LIT Flare Only)

Please review the table below and make sure you have received the kit contents.

Kit Contents	Qty
Diode Dynamics RGBW Controller	1
Positive Cable w/ In-Line Fuse	1
Power Cable w/ Pigtail Connector	1
Switch	1
Switch Ground Cable w/ Pigtail Connector	1
8" Zip Ties	5
Cable Clips	2
M6 x 12mm Cap Screw	1
M6 Lock Nut	1
Assembled LIT Flare	1



If you already own the Velossa Tech GEN 4 Elantra Sport BIG MOUTH, skip to slide 7 to see install and wiring instructions.



Bumper Removal

REMOVE BUMPER PRIOR TO ATTEMPTING INSTALLATION.

Use YouTube as a resource, there are many bumper removal videos to guide you.

Stock Components Removal

Once the bumper is removed, you will need to remove the transition tube that connects the cowl to the airbox or air filter feed.



Install the LIT BIG MOUTH Flare

SKIP THIS SLIDE IF YOU PURCHASED A FULL LIT KIT

Attach the supplied cable clip to your BIG MOUTH as shown. Fasten the cable and provide enough slack to not strain the cable.

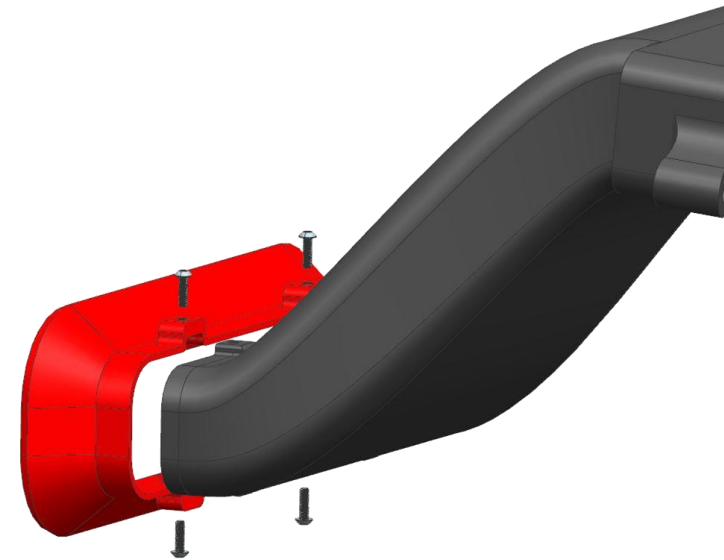

If you purchased a LIT flare-only and already have a Gen 4 BIG MOUTH. Remove old flare and install the LIT flare with the 4 screws as shown.

Big Mouth Installation

Hardware is supplied and **MUST NOT BE** mixed up.

M6 x 90mm bolt goes on the passenger side, M6 x 100mm bolt goes on the driver side.

BOLTS GO INTO THE PART FROM THE FRONT OF THE CAR.

Put a washer under the head side of each bolt.

M6x 90mm

M6x 100mm

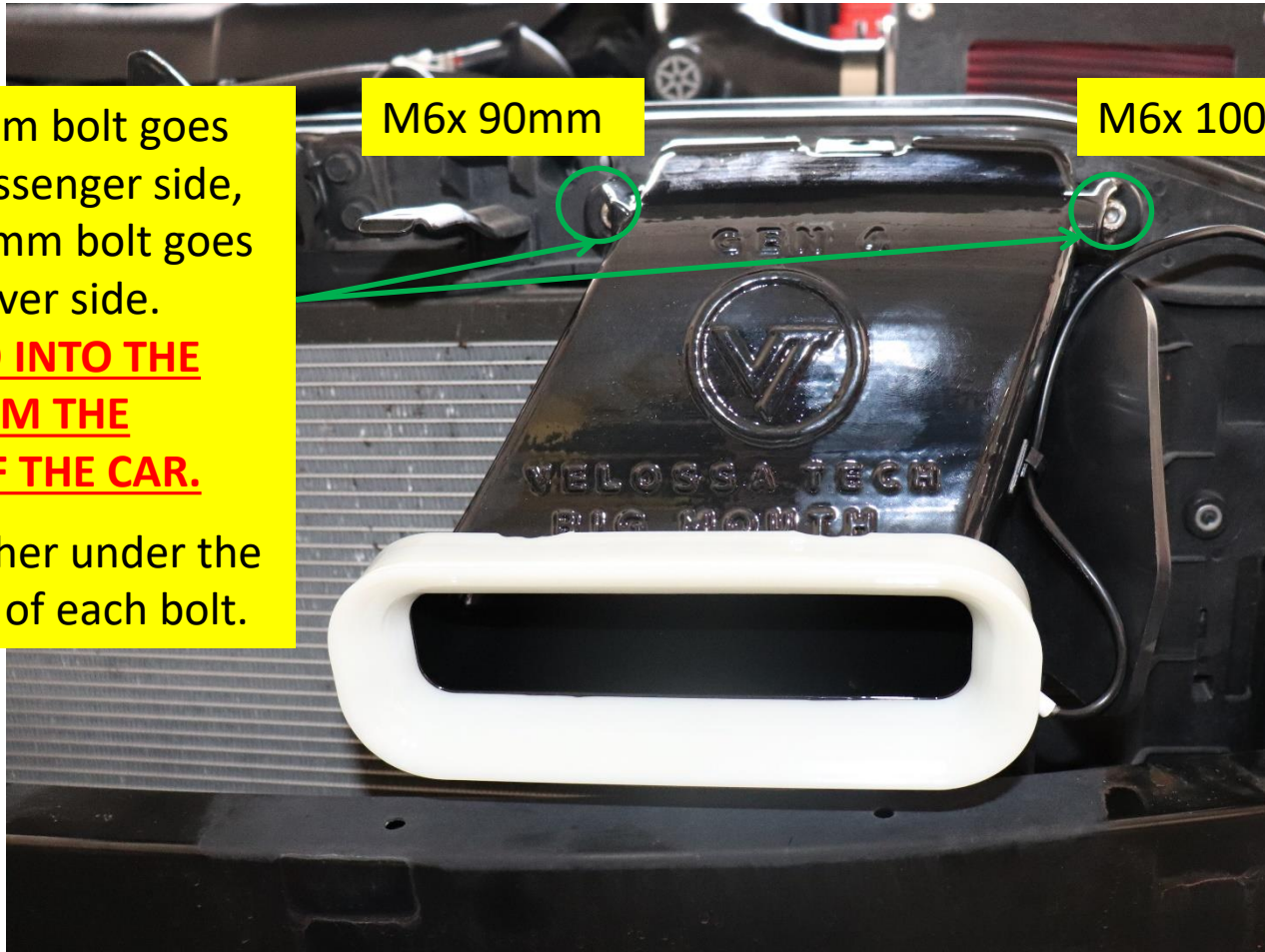

Thread the bolts into the stock threads and tighten snug, **DO NOT OVER TORQUE.**

Big Mouth Installation

Washer and nut go on back side,
ON TOP of the stock plastic cowl
rear piece.

Tighten down snug, DO NOT OVER TORQUE.

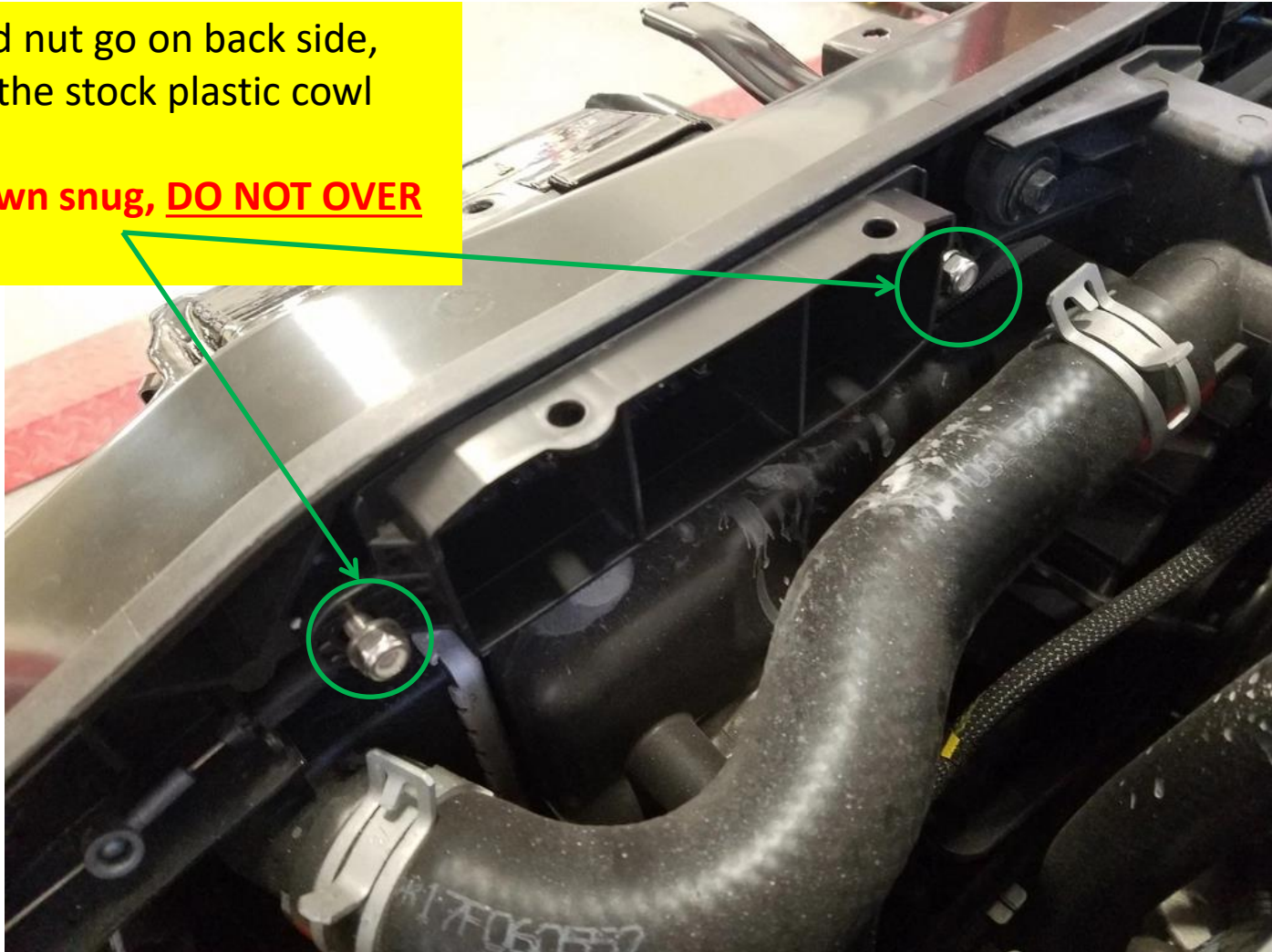



Big Mouth Installation

Re-install stock transition tube for best results.

Install the tube if you have an open element air filter, this will help direct airflow to the filter.





VELOSSA TECH

Wiring Harness

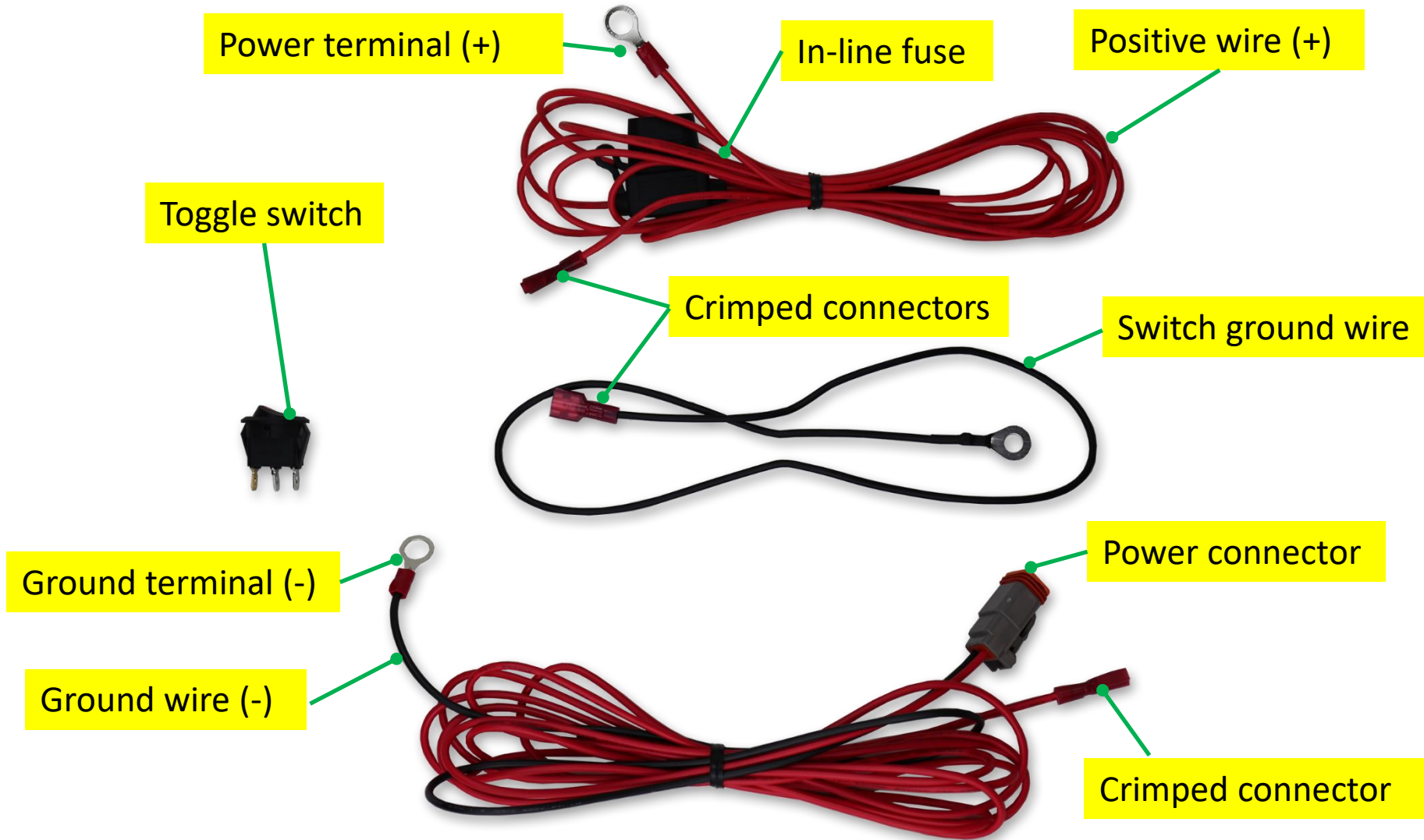



VELOSSA TECH

Wiring Harness Schematic

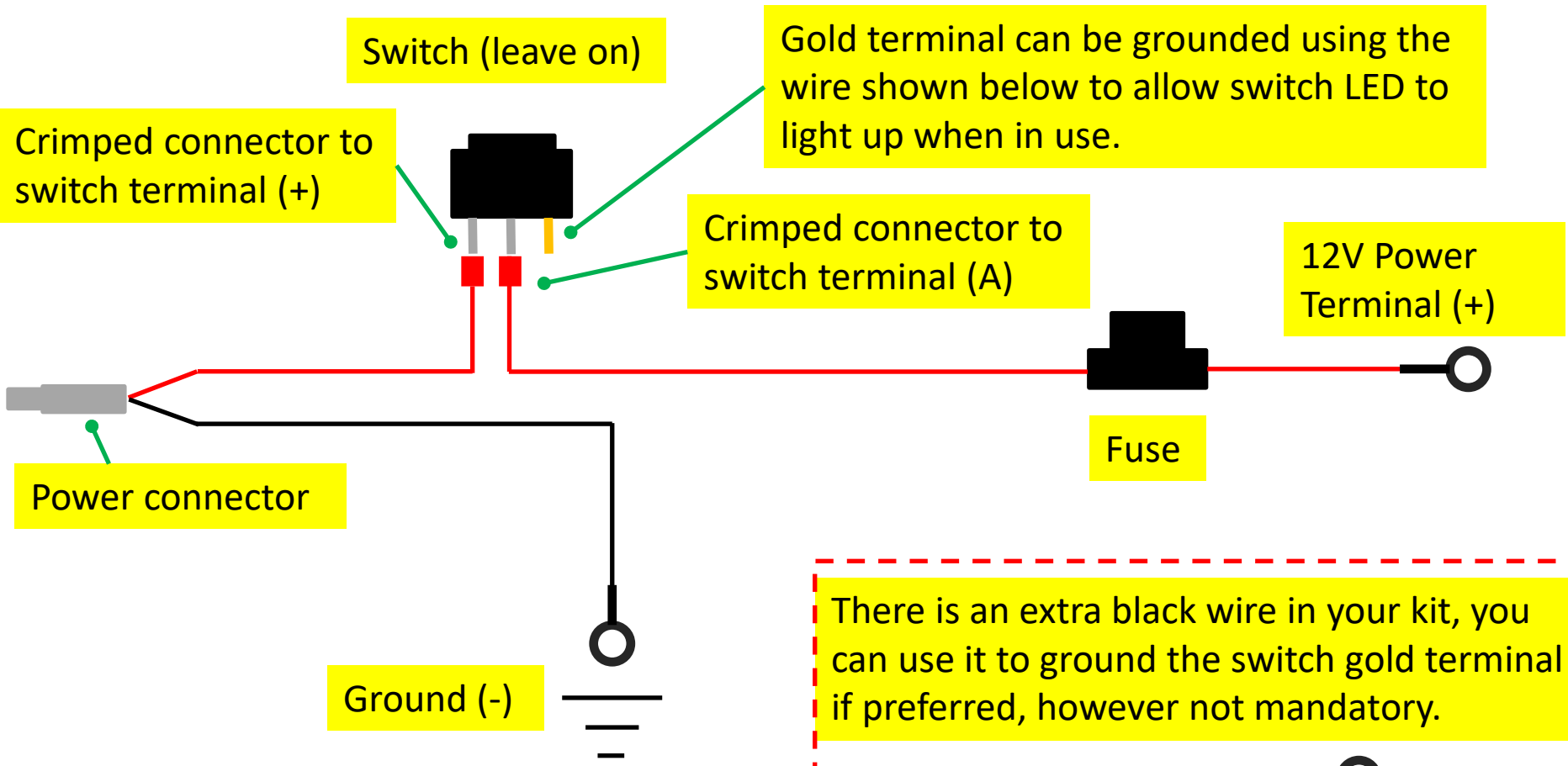

Switch (leave on)

Gold terminal can be grounded using the wire shown below to allow switch LED to light up when in use.

Crimped connector to switch terminal (+)

Crimped connector to switch terminal (A)

12V Power Terminal (+)

Fuse

Power connector

Ground (-)

There is an extra black wire in your kit, you can use it to ground the switch gold terminal if preferred, however not mandatory.

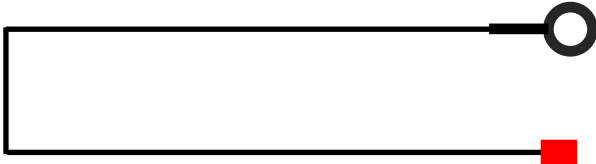

Controller

Zip tie the controller to the following location behind the driver side headlight. The controller is zip tied to the thick OEM electrical harness using two zip ties, one zip tie should loop through the DD controller slot and the other zip tie goes around the body and plug.

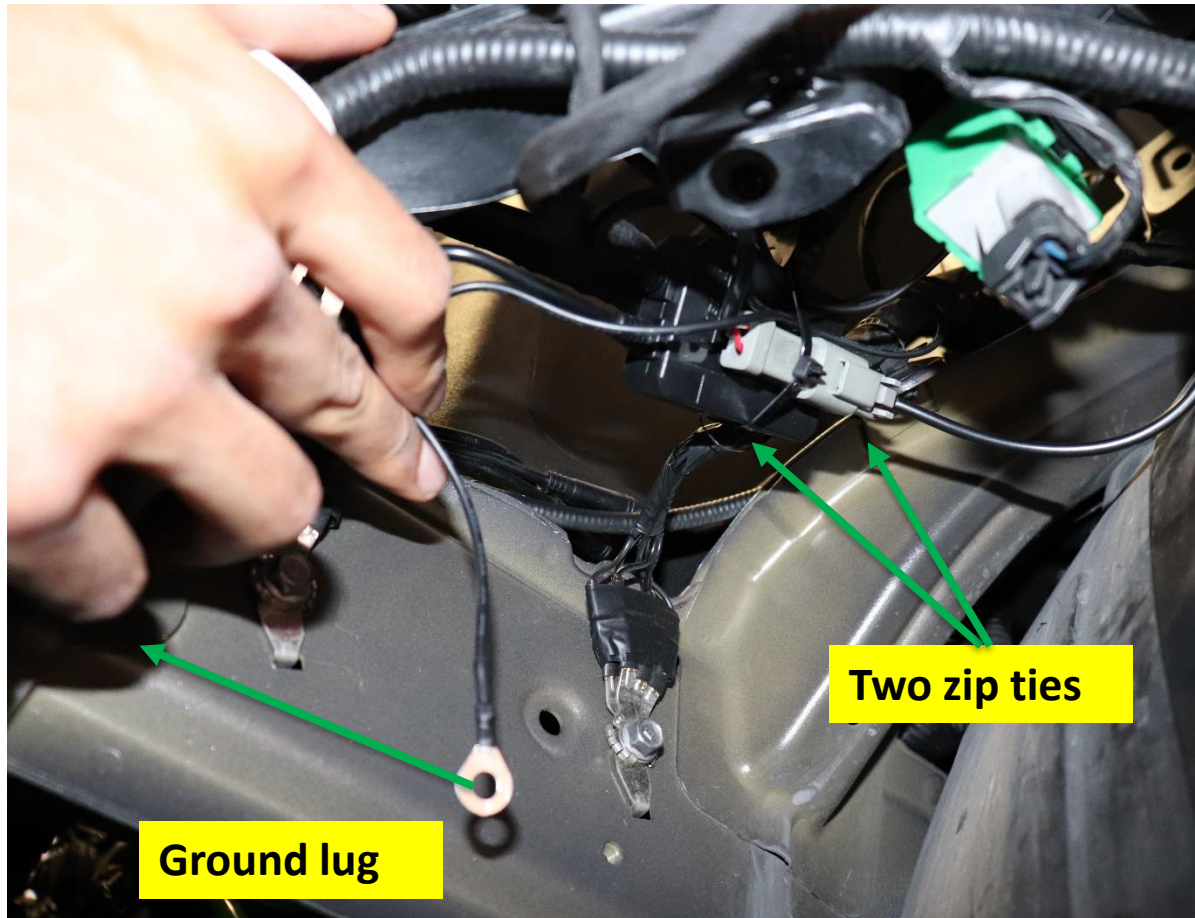

Controller

Ground the controller as shown with supplied 6mm bolt.

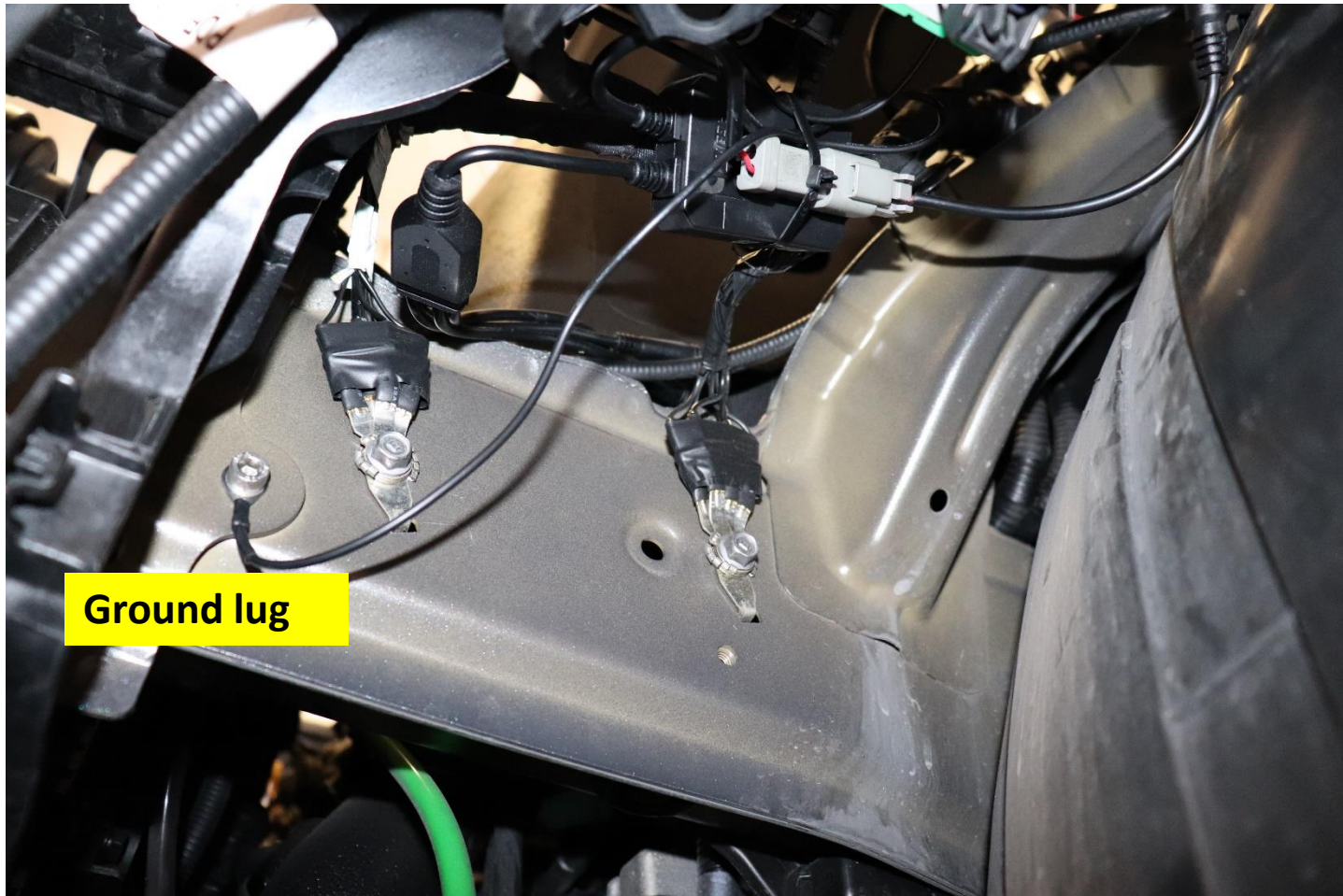

Wire Management

Snake the Diode Dynamics LED power wire from the BIG MOUTH as shown

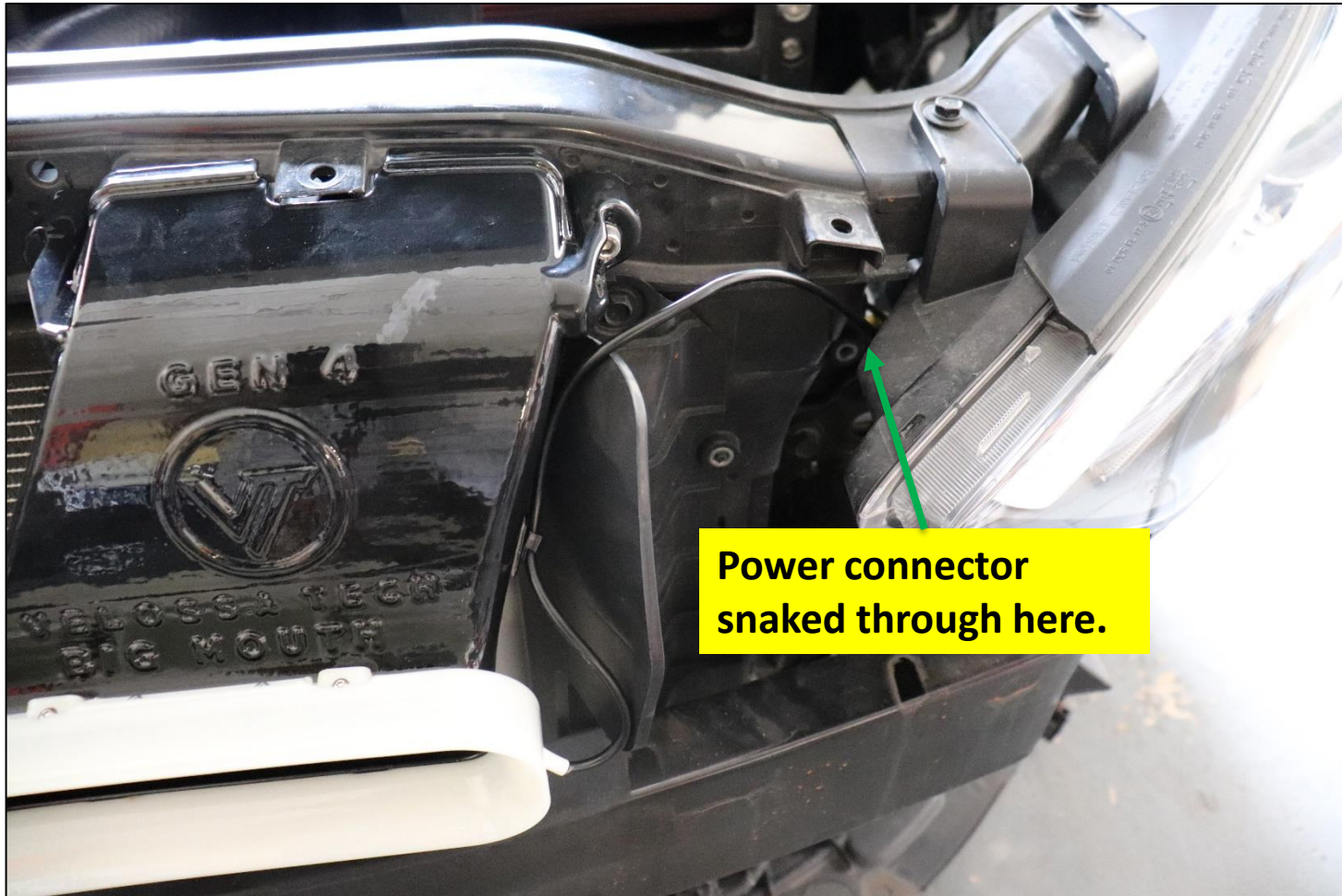

Wire Management

Connect to the Diode Dynamics controller into one of the 4 ports. You may zip tie the other 3 ports as shown.

Plugged into controller

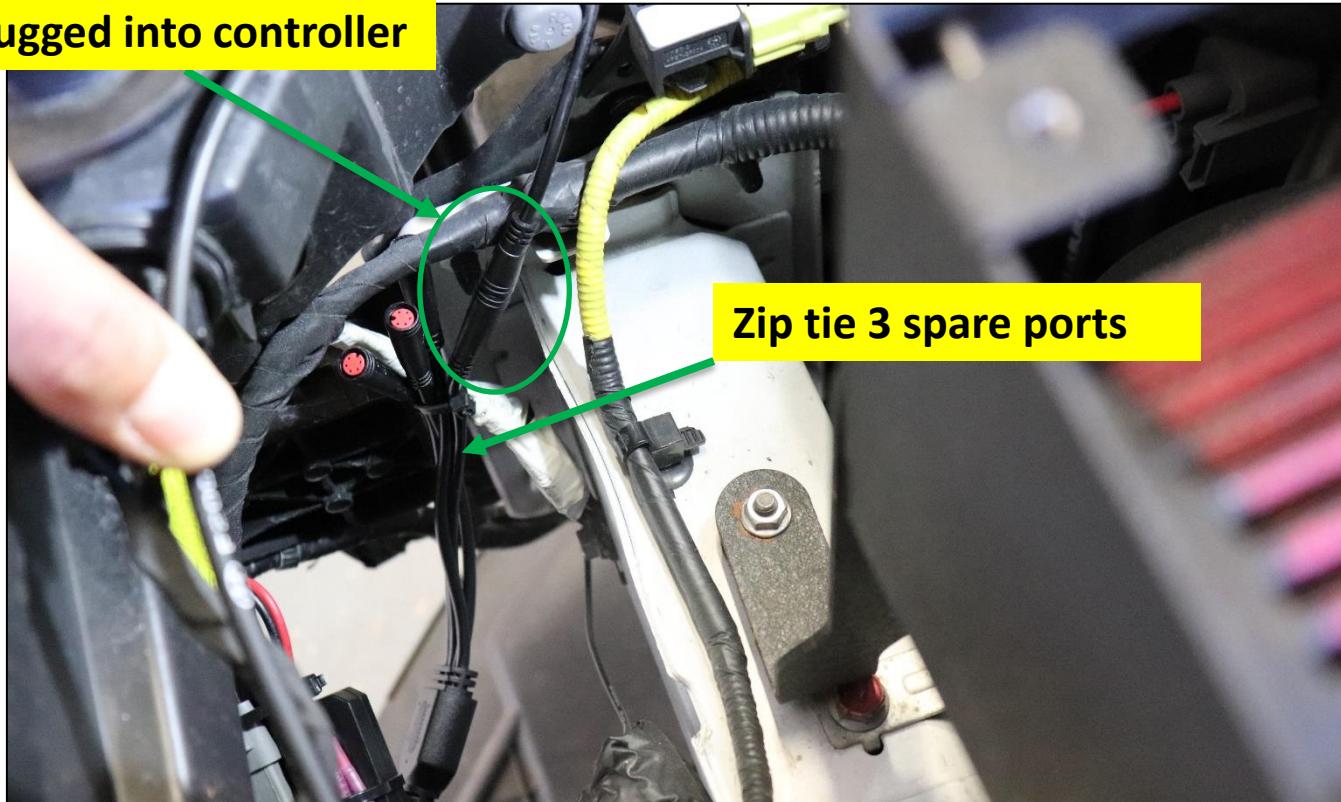

Zip tie 3 spare ports

Wire Management

You may zip tie the other 3 ports as shown.

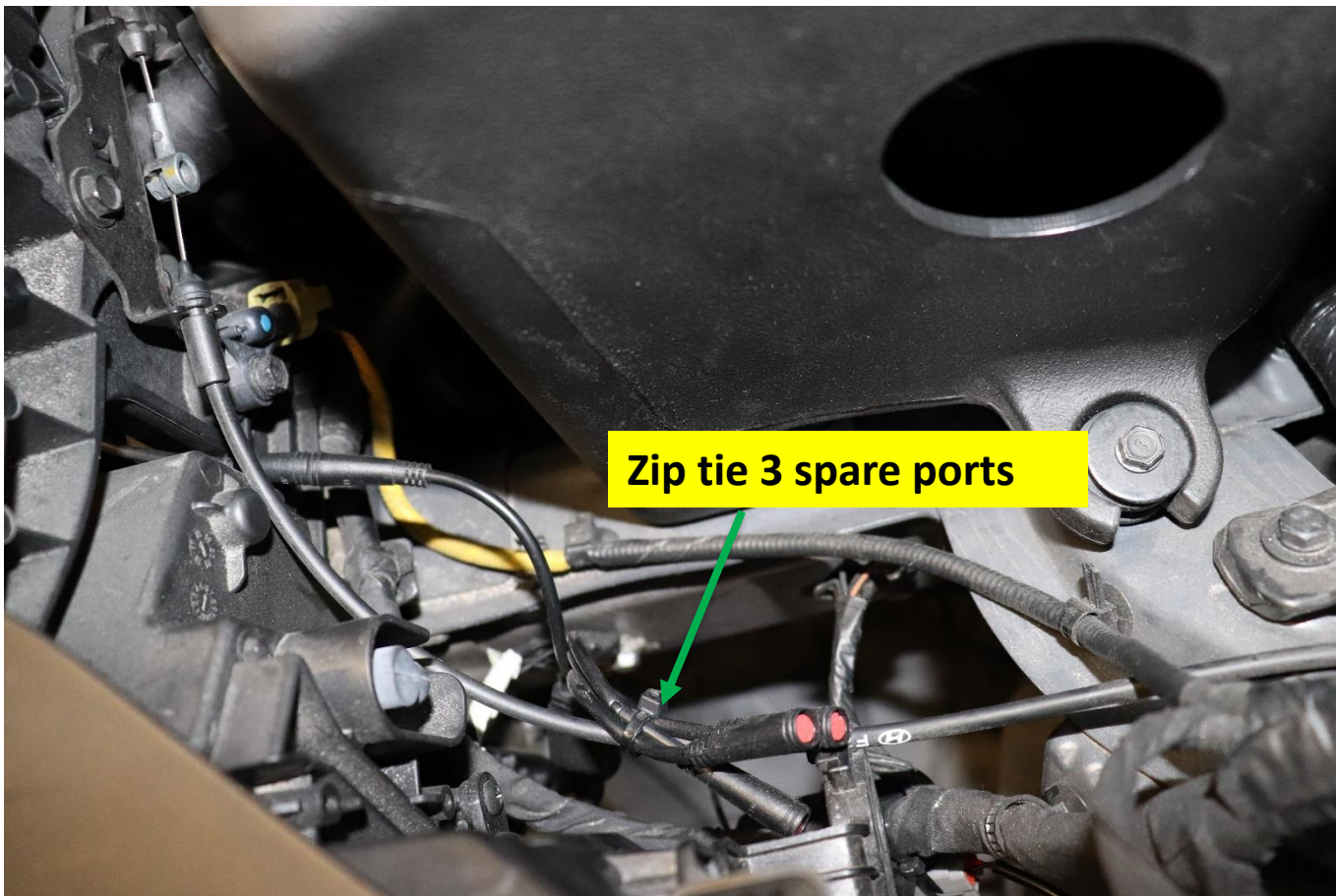

Power Hook-up

There will be excess power wire coming out of the power connector, bundle it neatly and zip tie, leave about a foot of power wire to make the power connection.

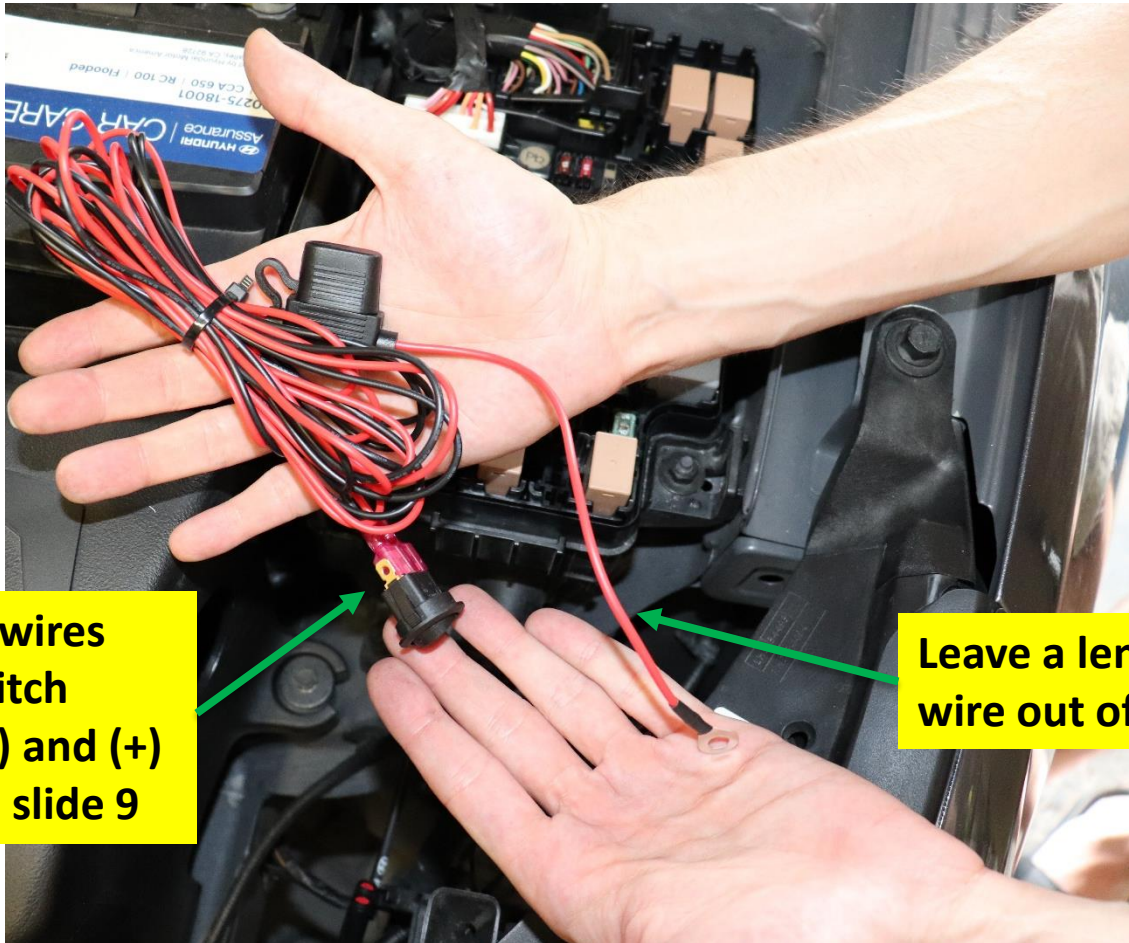

Both power wires plug into switch terminals (A) and (+) as shown on slide 9

Leave a length of power wire out of the bundle

Power Hook-up

Tuck away the bundle as shown, fasten power lug to (+) terminal in the fuse box on top of the OEM stud, use supplied M6 nut.

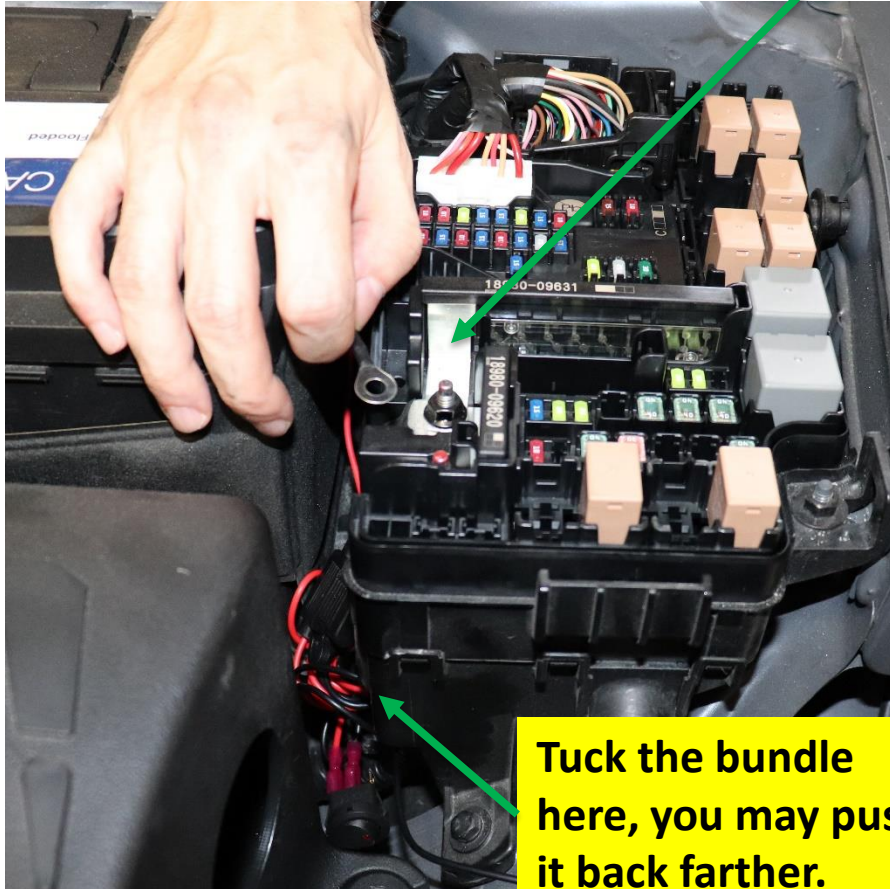

Tuck the bundle here, you may push it back farther.

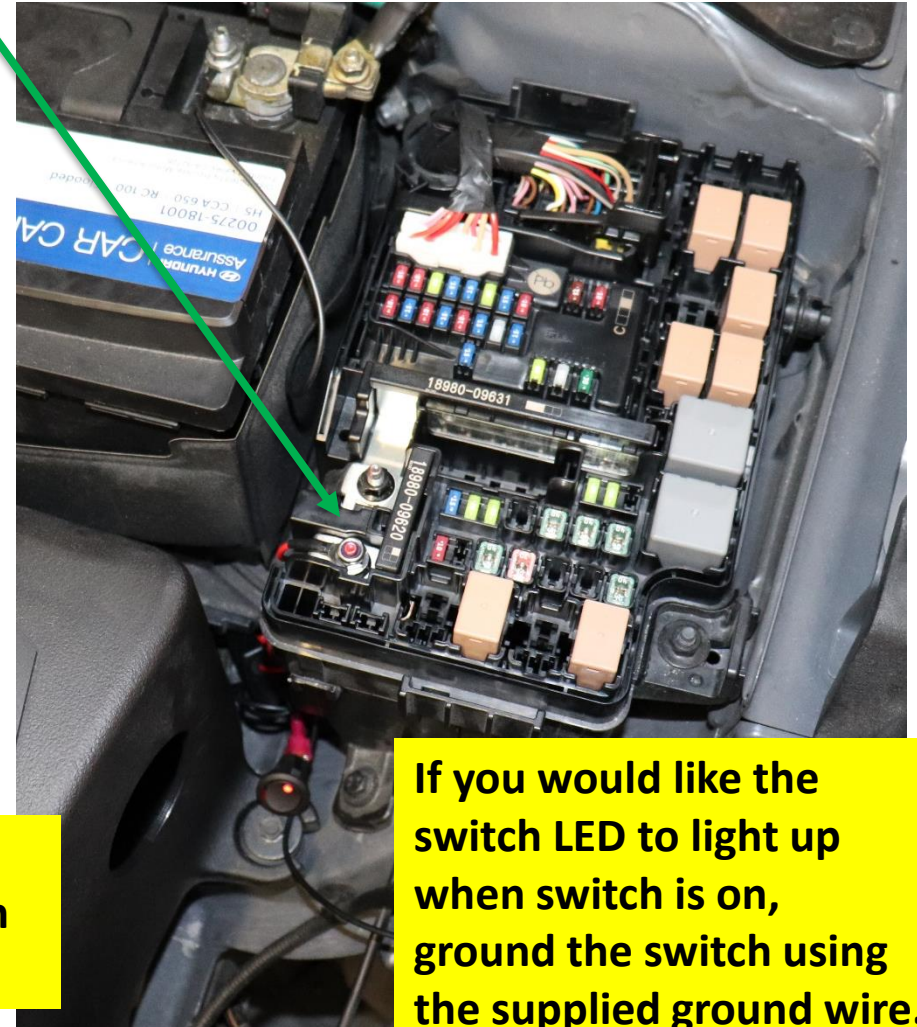

If you would like the switch LED to light up when switch is on, ground the switch using the supplied ground wire.

Power Hook-up

Switch ground: Optional

If you would like the switch LED to light up when switch is on, ground the switch using the supplied ground wire.

Once complete, put the fuse box cover back on, ensure no wires are pinched by the fuse box!

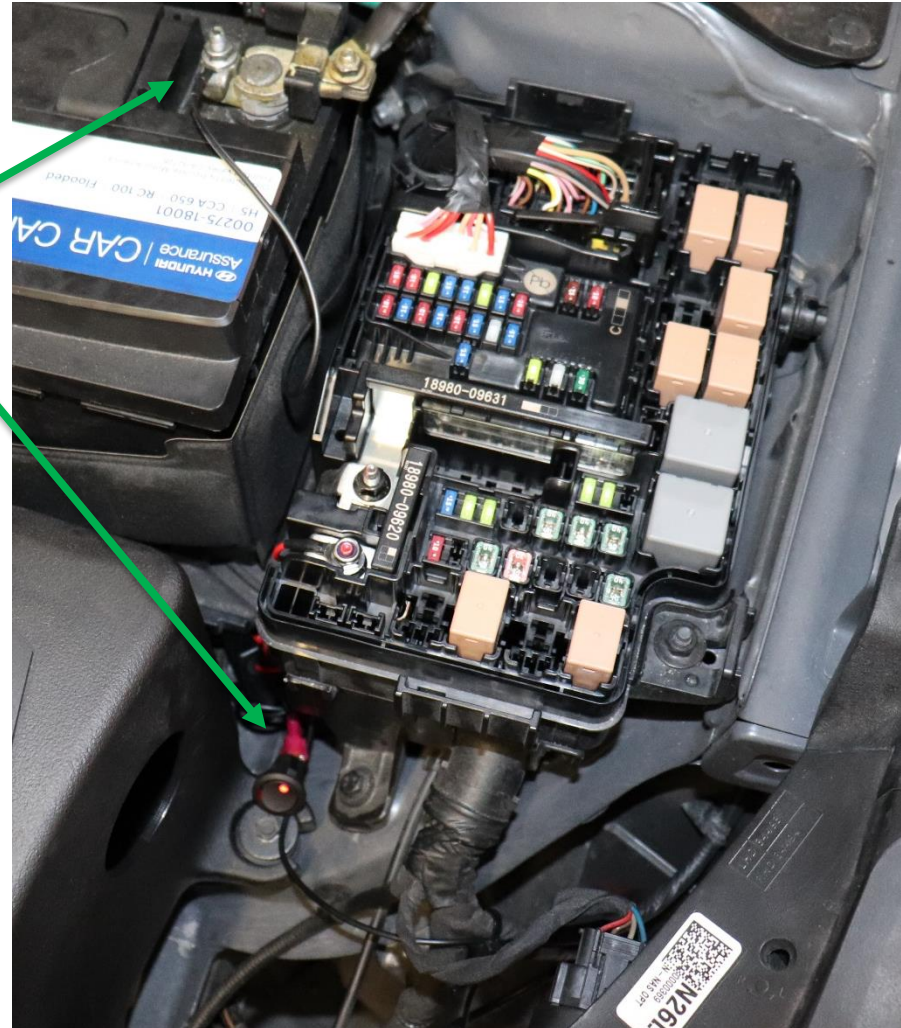

Phone App

Download the Diode Dynamics app and connect via Bluetooth.

How to connect to the app:

1. After installing the app from the app store, open the app on your device.
2. Cycle the power to the Bluetooth controller by unplugging it and plugging it back in or flick the power switch and wait a few seconds, then turn it back on.
3. Wait for the app to detect the controller, it will pop up on the app screen as a Bluetooth controller. If necessary, cycle the power once more to refresh the controller.
4. Once the controller shows up on the app, click it and connect. You have 30 seconds to select the controller once it shows up on the app. After 30 second you will need to refresh again to detect the controller again.
5. Note that if you mounted your controller behind a lot of metal components, this may degrade the signal and range.





Finalize

Re-install the bumper the same way it was removed and ENJOY!

