

CONCEPTUAL PHYSICS ALIVE! VIDEO QUESTION SET

# Magnetism & Induction

In this lecture, Paul Hewitt describes the effects of magnetism and electromagnetic induction. Read the following questions before the presentation begins. Answer them while the presentation is in progress. [41 minutes]

**1. Can Hewitt’s “dinky” magnet exert as much force on a pile of paperclips as the whole Earth?**

**2. What does a compass needle align with?**

**3. Hans Christian Ørsted’s discovery led to the understanding that the source of all magnetism is \_\_\_\_\_**

**4. When the current is turned off, the diagram to the left shows the compass alignments. Draw the compass alignments when the current is turned on in the diagram to the right.**

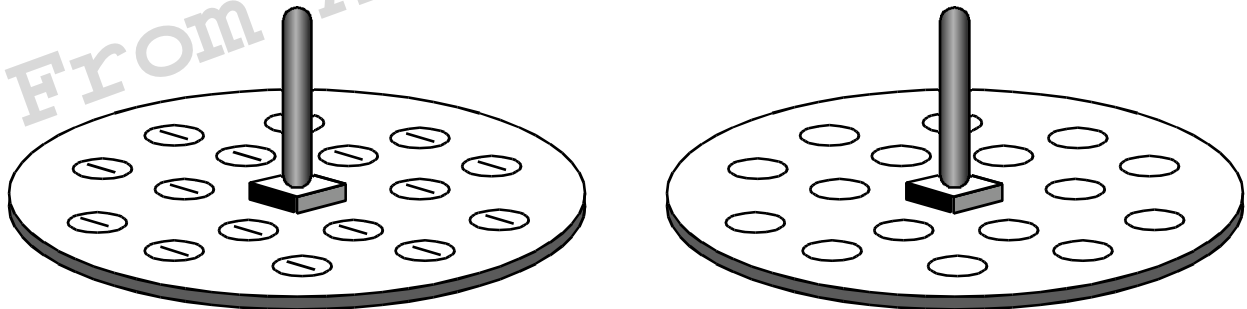

**5. Which procedure or procedures will weaken a magnet? (Select all that are correct.)**

- A. dropping it and letting it strike the floor**
- B. throwing it against the wall**
- C. throwing it in a fire**
- D. putting it on a low-protein diet and not letting it exercise**

**6. Where is the moving electric charge in the natural (or permanent) magnet?**

**7. What happens if a loop of current is passed through a magnetic field?**

- A. both sides get pushed up**
- B. both sides get pushed down**
- C. no force up or down**
- D. one side is pushed up, the other side is pushed down**

**8. To turn a meter movement into a motor movement, it's important that the direction of current in the loop be reversed every...**

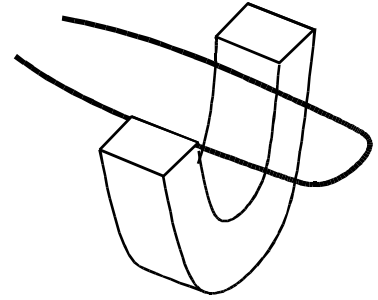

**9. What determines the speed of the motor?**

- A. the strength of the current**
- B. the strength of the magnetic field**
- C. both of these**
- D. none of these**

**10. Michael Faraday and Joseph Henry discovered it was possible to generate electric current without batteries by doing what? (“One can induce a voltage by....”)**

**11. Ted Bradstrom’s demo: Suppose a magnet were moved in and out of a coil of wire. And suppose the coil of wire were connected to another coil of wire.**

- A. Moving the magnet in the first coil causes changes in the magnetic field in the second coil.**
- B. Moving the magnet in the first coil doesn’t cause any changes in the magnetic field in the second coil.**

**12. Identify two more applications of electromagnetic induction.**

**i.**

**ii.**

# CONCEPTUAL PHYSICS ALIVE! VIDEO QUESTION SET

# Magnetism & Induction

In this lecture, Paul Hewitt describes the effects of magnetism and electromagnetic induction. Read the following questions before the presentation begins. Answer them while the presentation is in progress. [41 minutes]

**1. Can Hewitt's "dinky" magnet exert as much force on a pile of paperclips as the whole Earth?**

Yes. [It can even exert more force than the earth.]

**2. What does a compass needle align with?**

The magnetic field of the Earth

**3. Hans Christian Ørsted's discovery led to the understanding that the source of all magnetism is \_\_\_\_\_ moving \_\_\_\_\_ electric \_\_\_\_\_ charges \_\_\_\_\_.**

**4. When the current is turned off, the diagram to the left shows the compass alignments. Draw the compass alignments when the current is turned on in the diagram to the right.**

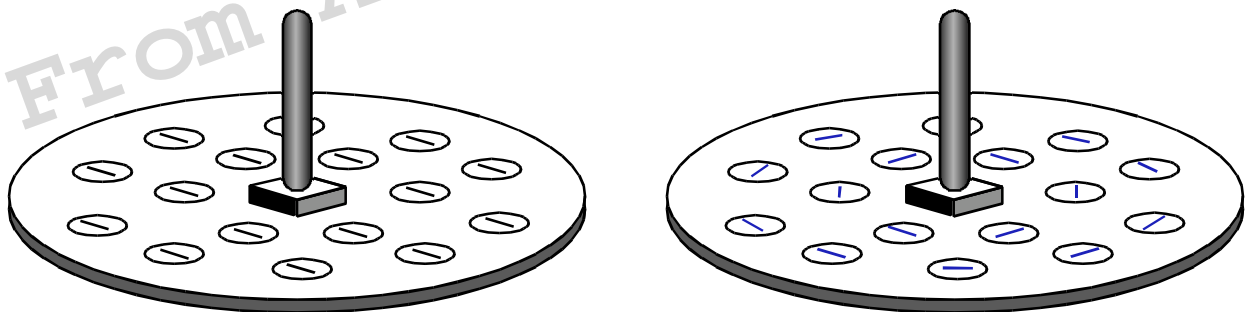

**5. Which procedure or procedures will weaken a magnet? (Select all that are correct.)**

**A. dropping it and letting it strike the floor**

**B. throwing it against the wall**

**C. throwing it in a fire**

**D. putting it on a low-protein diet and not letting it exercise**

6. Where is the moving electric charge in the natural (or permanent) magnet?

In the atoms—the motion of the electrons.

7. What happens if a loop of current is passed through a magnetic field?

A. both sides get pushed up

B. both sides get pushed down

C. no force up or down

D. one side is pushed up, the other side is pushed down

8. To turn a meter movement into a motor movement, it's important that the direction of current in the loop be reversed every...

half-turn.

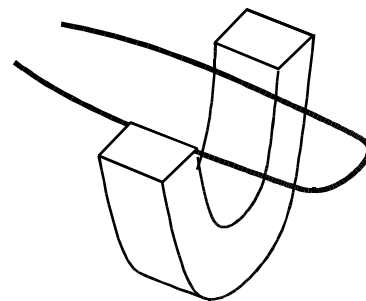

9. What determines the speed of the motor?

A. the strength of the current

B. the strength of the magnetic field

C. both of these

D. none of these

10. Michael Faraday and Joseph Henry discovered it was possible to generate electric current without batteries by doing what? (“One can induce a voltage by....”)

moving a wire in and out of a magnetic field

-or-

changing the magnetic field in a closed loop of wire

11. Ted Bradstrom’s demo: Suppose a magnet were moved in and out of a coil of wire. And suppose the coil of wire were connected to another coil of wire.

A. Moving the magnet in the first coil causes changes in the magnetic field in the second coil.

B. Moving the magnet in the first coil doesn’t cause any changes in the magnetic field in the second coil.

12. Identify two more applications of electromagnetic induction.

i. Smart Lights - traffic signals that change when cars approach.

ii. Tape Recorder