

## INSTRUCTIONAL GUIDE

### Contents

- Hollow Acrylic Accelerometer Grid
- Wooden Stand
- 2 Thumb Screws
- 2 Plastic Screws
- Dye
- Clear Dye Container

Recommended for activities:

- [Dynamics Carts \(P3-3530\)](#)
- [Table Clamp Pulley \(P1-6115\)](#)
- [No-Stretch Pulley String \(P1-6110\)](#)
- [Hooked Mass Set of 9 \(91-1000\)](#)



### Background

The Liquid Accelerometer is intended to illustrate acceleration in various dynamic situations. The device is a clear rectangular container partially filled with fluid with 1 cm grid markings on one surface. Accelerations along the longitudinal axis will produce a slope of the surface of the liquid, which may be taken directly from the grid for quantitative data.

### Instructions

A container of colored fluid is included to be used as the liquid medium. To fill, remove the #10.32 screw on the back surface of the accelerometer and fill with the accelerometer fluid to the "0" grid line. A small aperture dropper or syringe is best to use for this operation. After filling, replace the #10.32 screw securely.

A wooden stand is also included. For experiments using the stand, assemble the accelerometer with the stand by loosening the wing nut and inserting the lower edge of the accelerometer in the slot in the wooden stand (See drawing at right). Tighten the wing nut securely.

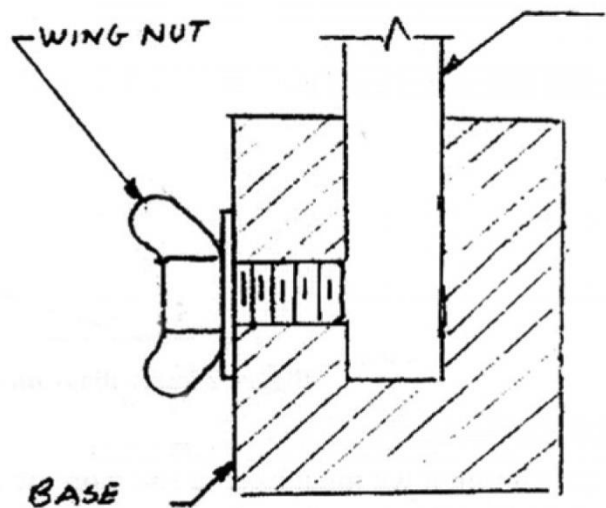

## Operation

When the accelerometer moves with constant linear acceleration along a horizontal surface, the surface of the water is a straight line whose slope is:

$$\tan \theta = a/g$$

Figure 1 is a force diagram of an infinitesimal element of liquid on the surface. When the liquid is in its steady state, the  $F_L$  exerted on the element by the rest of the liquid is normal to the surface. If the force did have a tangential component, the liquid would flow until it attained a steady state.

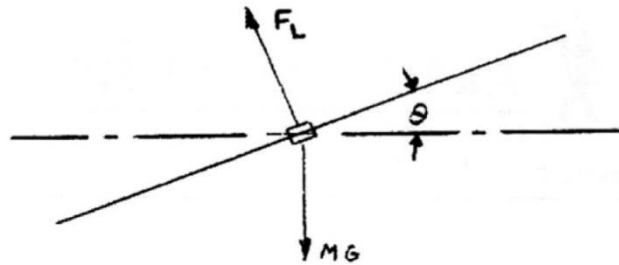

**Figure 1 Force diagram of infinitesimal element of liquid on the surface.**

The net vertical force is:

$F_L \cos \theta - mg$  and the net horizontal force is  $F_L \sin \theta$

From Newton's Laws:

$F_L \cos \theta - mg = 0$ , or  $F_L \cos \theta = mg$ , also  $F_L \sin \theta = ma$ .

Hence,  $\tan \theta = a/g$

Since the equation is true at every point on the surface, the surface is a straight line.

In particular, if there is no acceleration, then  $a = 0$ ,  $\tan \theta = 0$  and the surface is horizontal. When the accelerometer is at rest on an inclined plane, as shown in Figure 2, the surface is still horizontal.

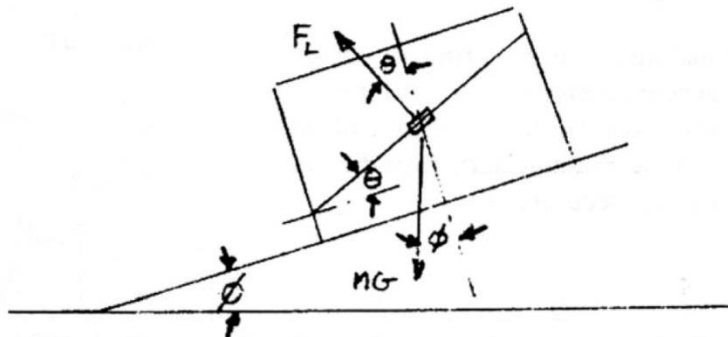

**Figure 2 Force diagram when the accelerometer is at rest on an inclined plane.**

Although we must exert a force on the accelerometer to keep it at rest, the only forces acting on our infinitesimal surface element are still  $F$  and  $mg$ . Then the next force perpendicular to the incline is:

$$F \cos \theta - mg \cos \phi$$

and the net force parallel to the incline is:

$$F \sin \theta + mg \sin \phi$$

There is no  $F_L \cos \theta - mg \cos \phi = 0$ , so  $F_L \sin \theta + mg \sin \phi = 0$ .

Then  $F_L = [mg \cos \phi] / \cos \theta$  or  $[mg \cos \phi \sin \theta] / \cos \theta + mg \sin \phi = 0$ , and  $\tan \theta + \tan \phi = 0$ .

Hence,  $\theta = 2\pi - \phi$ . That is, the surface is horizontal.

When the accelerometer moves on the inclined plane under the force due to gravity, the surface of the liquid is parallel to the plane. The acceleration along the plane is:

$$\phi a = g \sin \phi$$

Thus, from Newton's Laws,

$$F_L \sin \theta + mg \sin \phi = ma = mg \sin \phi \text{ and } F_L \sin \theta = 0, \text{ or } \theta = 0.$$

If the frictional force  $F_{fr}$  on the inclined plane is appreciable, the surface of the liquid will not be horizontal. When the cart moves downhill, the forces act as in Figure 3. Then,

$$F_L \sin \theta + mg \sin \phi - F_{fr} = ma = mg \sin \phi \text{ and } F_L \cos \theta - mg \cos \phi = 0$$

$$\text{Hence, } F_L \sin \theta = F_{fr}$$

$$F_L = [mg \cos \phi] / \cos \theta$$

$$\tan \theta = F_{fr} / mg \cos \phi$$

$$\text{Thus, } [mg \cos \phi \sin \theta] / \cos \theta = F_{fr}$$

If the cart moves uphill, the  $\sin$  of  $F_{fr}$  is reversed, and  $\theta$  has the opposite direction. If  $F_{fr} = 0$ , then  $\tan \theta = 0$  and the surface is horizontal.

When the accelerometer rotates with constant angular velocity, the surface is parabolic. Let  $y$  be the height of the water and  $x$  the distance from the center, as shown in Figure 4.

$$\text{Then } dy/dx = \tan \theta = a/g$$

$$\text{For uniform circular motion } a = w^2 x.$$

Hence,  $dx = (w^2 x^2) / 2g + \text{constant}$  which has the form  $y - (x^2 + \text{constant})$  for a parabola.

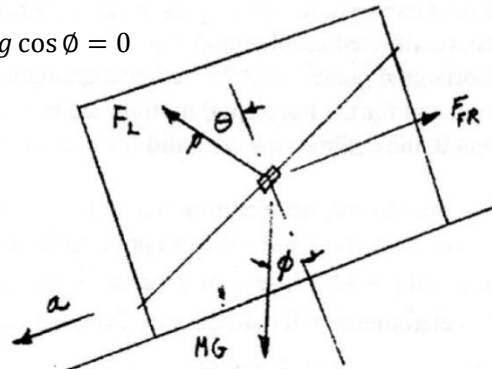

Figure 3 Force diagram when the accelerometer is moving down the slope.

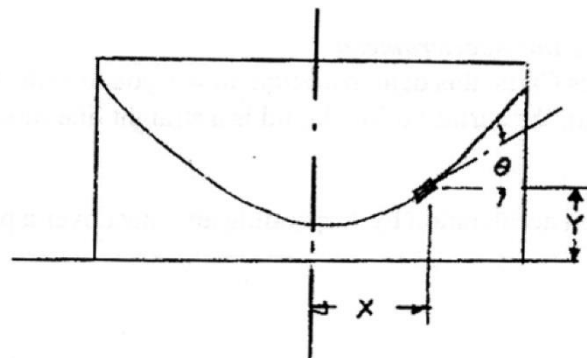

Figure 4 Accelerometer on rotating turntable.

You can calibrate the accelerometer by using the wooden stand and the kinematic equation  $d = \frac{1}{2} at$ . Attach the accelerometer to an air trough glider, keeping the bottom of the accelerometer horizontal. Place the cart on an inclined air trough, release and record the slope of the liquid as the cart moves downhill by noticing the height of the liquid against the markings on the cell. Also, measure the time of motion and calculate  $a = 2d/t^2$ , where  $d$  is the distance the cart travels along the incline.

By changing the slope of the incline, you can change the acceleration of the cart and hence calibrate the accelerometer over a range of accelerations. As long as the frictional force is constant, it does not affect calibration. As long as the angle  $\theta$  between the horizontal and the surface of the liquid is small, this calibrated accelerometer would also accurately measure the acceleration of an object moving in a horizontal plane. The theoretical explanation is that for the arrangement on the inclined plane,  $\sin \theta = a/g$ , and for the horizontal motion,  $\tan \theta = a/g$ . For angles less than  $15^\circ$   $\sin \theta$  is approximately equal to  $\tan \theta$ , the calibrations are valid for both types of motion.

In order to take acceleration readings directly from the unit, place a length of centimeter tape in a vertical position at the 9.8 cm point indicated on the accelerometer as shown in Figure 5. Since  $\tan \theta = a/g$  and  $g = 32.2 \text{ ft/sec}^2$  or  $9.8 \text{ m/sec}^2$ , then the tape placed at 9.8 cm from the center of the accelerometer will read directly from the centimeter tape in units of meters/sec<sup>2</sup>.

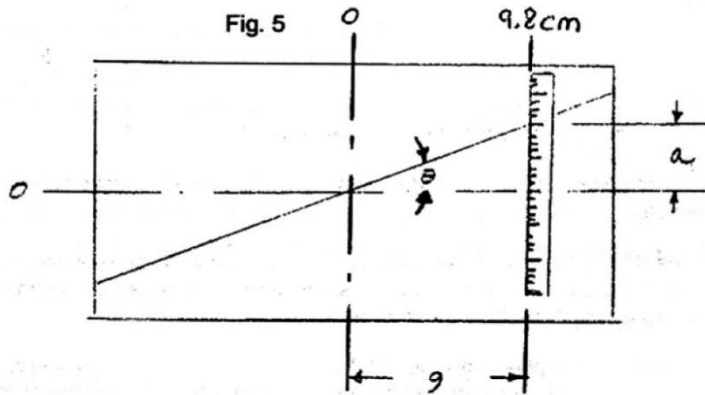

Figure 5 Arrangement for acceleration readings directly from the unit.

### Uniform Acceleration Using the Accelerometer:

Using the P3-3530 **Dynamics Carts**, this demonstration allows you to show that when a cart moves with constant acceleration ( $a$ ), the surface of the liquid is a straight line tilted in the direction of the acceleration.

Give the cart uniform acceleration by suspending an object over a pulley as in Figure 6.

It is best to use objects with masses ranging from 100 – 400 grams. It is important to keep the string as long as possible, so that you use the entire length of the table. By changing the mass of the suspended object, you can vary the acceleration of the cart. Notice that the slope of the liquid increases with greater acceleration. The slope is thus a measure of the acceleration. It can be shown that  $\tan \theta = a/g$  so that  $a = g \tan \theta$ .

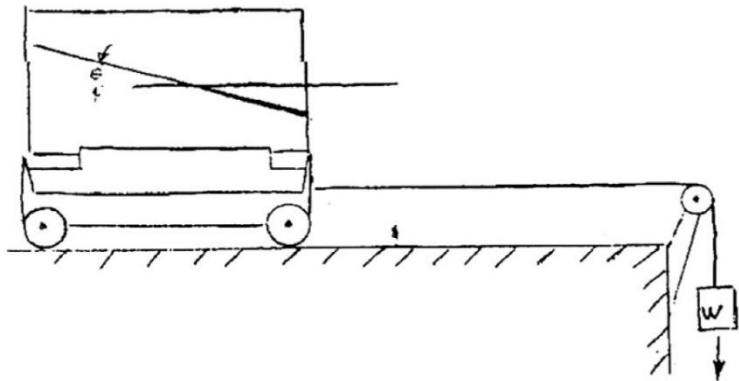

Figure 6 Arrangement to demonstrate uniform acceleration.

### The Effect of Friction on Acceleration:

The previous demonstration works only if friction is negligible. Since the direction of the frictional force  $F_{frict}$  is always opposite to the velocity you can show the effect of friction on acceleration by attaching tape with adhesive on both sides to the wheels of the cart.

When the cart moves to the right, the horizontal forces acting in it are illustrated in Figure 7. The acceleration is then:  $a = T - F_{frict}/M$  where  $M$  is the mass of the cart plus the accelerometer.

The tension ( $T$ ) is simply the weight of the object hanging over the pulley and is independent of the velocity.

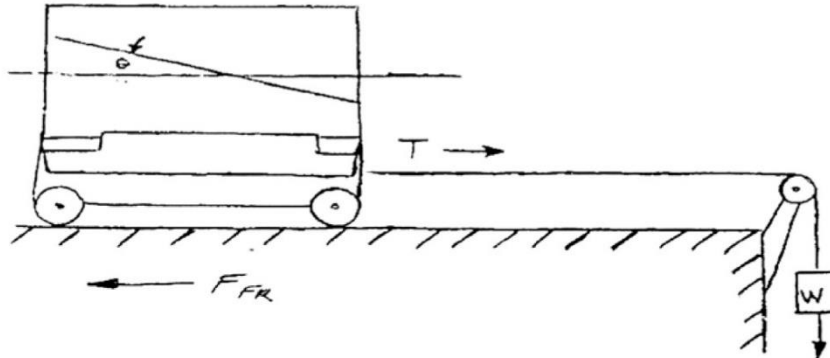

Figure 7 Force diagram when cart is moving to the right.

When the cart moves to the left, however, the forces act as in Figure 8. The acceleration is now:

$$a = T + F_{frict}/M$$

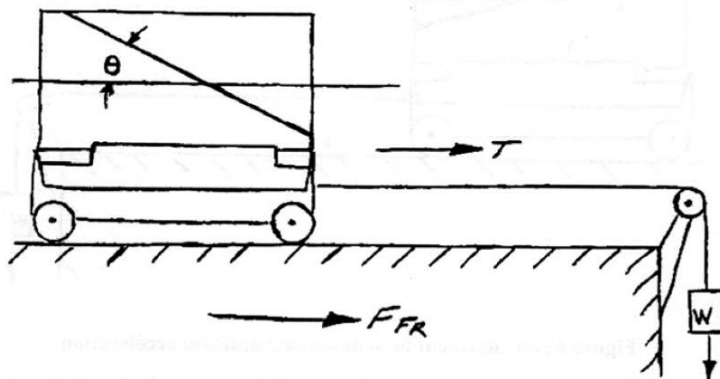

Figure 8 Force diagram when cart is moving to the left. The change in  $\theta$  is exaggerated.

Since the acceleration is less when the cart moves to the right than when it moves to the left, the slope of the water when the cart moves to the right will also be less. This difference in slopes is slight, but not noticeable.

## Related Products

**Inclined Plane (P3-3541)** A versatile and sturdy inclined plane that attaches easily to a stand (not included) and adjusts to any height.

**Human Dynamics Cart (P3-3617)** Active involvement turns into fun physics! When a student sits on the Dynamics Cart, they actually become part of the experiment, creating a real-world experience that teaches concepts like Newton's First Law.

**Four-sided Friction Block (P3-3608)** Our 4-sided Friction Block makes friction experiments quick and easy. Surfaces include paper, wood, sandpaper and vinyl. Threaded brass post allows for easy addition of slotted masses.