

INSTRUCTIONAL GUIDE

Contents

- Laser Tank
- Base
- Laser with detachable housing
- Four prisms: semi-circular lens, plano-concave lens, plano-convex lens, double convex lens
- Two mirrors: plane, concave/convex
- Beam splitter
- Instructional Guide



Background

The history of optics is as old as the ancient Egyptians and Mesopotamians where lenses were made of polished crystal such as quartz. Water-filled glass spheres were used as lenses by the ancient Greeks and Romans, and glass came into use as a lens in the Middle Ages. Euclid, a mathematician, was one of the first known writers to share his observations as he studied optics in terms of geometry. Johannes Kepler studied optics as part of his lunar and astronomical investigations in the early 1600s. Willebrord Snellius determined the law of refraction and shared it as Snell's law at nearly the same time that René Descartes used the same law to determine the angular radius of a rainbow and independently defined the law of reflection. Isaac Newton experimented with lenses and prisms to investigate light refraction and created an entire theory of color. As the nature of light has become better understood, the field of optics continues to grow and expand—even into the realm of quantum physics, where Max Planck, Niels Bohr, and Albert Einstein, among many others, have made their mark.

Introduction

Optical theories become more real and approachable as students see beams of light shining through and away from various materials and shapes with the Laser Refraction Tank. Refraction and reflection become measurable and graspable with a laser light shining through and off of water, lenses, and mirrors.

1. Switch
2. Battery
3. Battery case
4. Hand wheel
5. Laser source
6. Splitter
7. Dial face
8. Water tank
9. Regulator knob

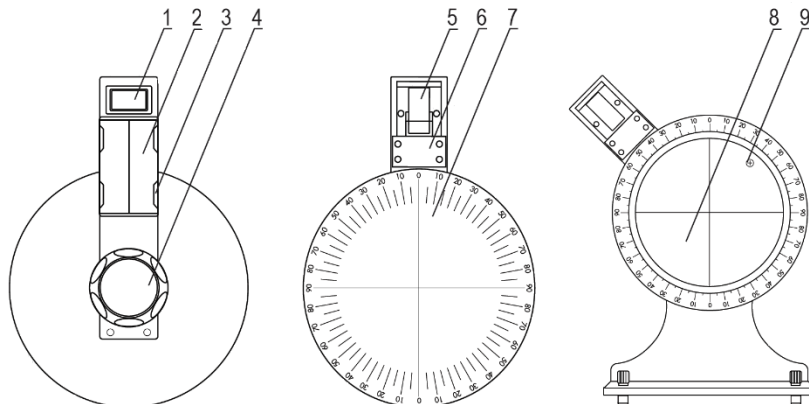

This self-contained unit can clearly and vividly demonstrate refraction, reflection and total internal reflection as well as define the critical angles of two different materials. The angle of incidence and refractive rays is easily seen with the help of a built-in laser. The laser revolves around the circular graduated scale and can be set at any point. Students can easily observe light rays as they travel from air into water, water into air, and water into water.

The Dial Face and laser unit can be removed from the tank and positioned horizontally on a table to carry out refraction and reflection experiments in a solid medium such as with the optical elements provided. Multiple parallel laser beams are available in refraction and reflection experiments. The optics elements allow students to see how light can be bent as it travels from air into a clear solid and then bends again as it travels out again into air. Different shapes of lenses and mirrors refract and reflect light in predictable ways.

Understanding why the light bends, requires understanding light as a wave. As the wave front crosses the boundary from a less-dense medium to a more-dense medium it slows down. If the light is at an angle to the boundary, one edge of the wave changes speed before the other edge. In order to maintain the integrity of the wave, the light must bend.

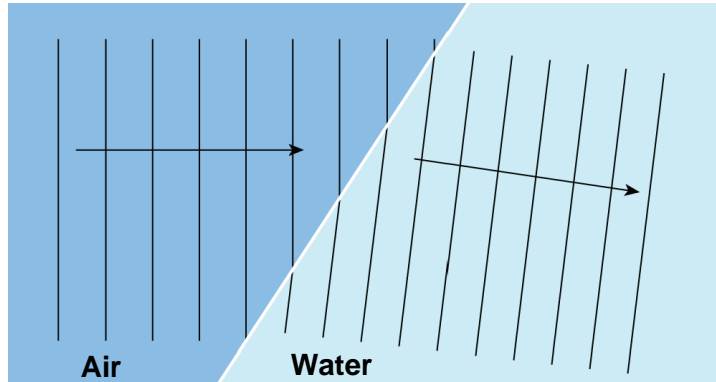

Activities

Refraction Tank Activities:

1. Fill the refraction tank half way with water. Shine the laser from different angles around the circle. Demonstrate refraction and reflection of light as well as total internal reflection with a critical incident angle as light passes from water to air. (Figure 1)
2. Explore refraction and total internal reflection further by changing some of the variables. Compare the angles of refraction for different liquids given the same angle of incidence. Note that clean up may be more difficult for some liquids.
3. More advanced students can use their measurements to demonstrate or test Snell's law. Use Snell's law to determine the index of refraction for different mediums (the index of refraction for air is 1.00029). Alternatively, use Snell's law to predict the angle of refraction given known indices of refraction. Test your predictions.

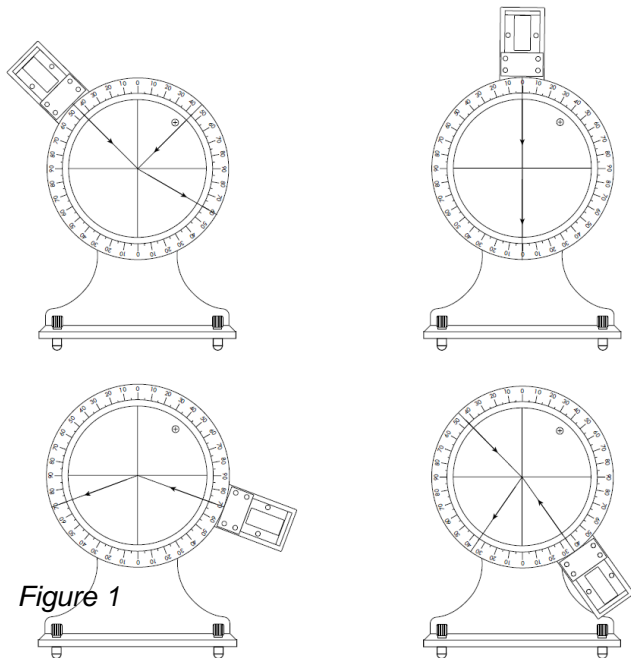

Figure 1

4. Observe diffuse reflection of light by adding colloid or emulsion to tank. Mixing in 5 ml of coffee creamer is one option.
5. After students have had a chance to make qualitative and/or quantitative observations about several different liquids, provide small groups with a “mystery liquid” to identify based on its refractive qualities.

Semi-circular Lens Activities:

1. Use the semicircle lens in much the same way as the refraction tank to explore refraction and reflection when light passes from air into a clear solid or from a solid into air (Figure 2). Students should make observations about the relationships between the angle of incident and the angle of reflection and the angle of refraction and at what angle total internal reflection occurs. What are the differences between starting in air and passing into the solid versus starting in the solid and passing into air?

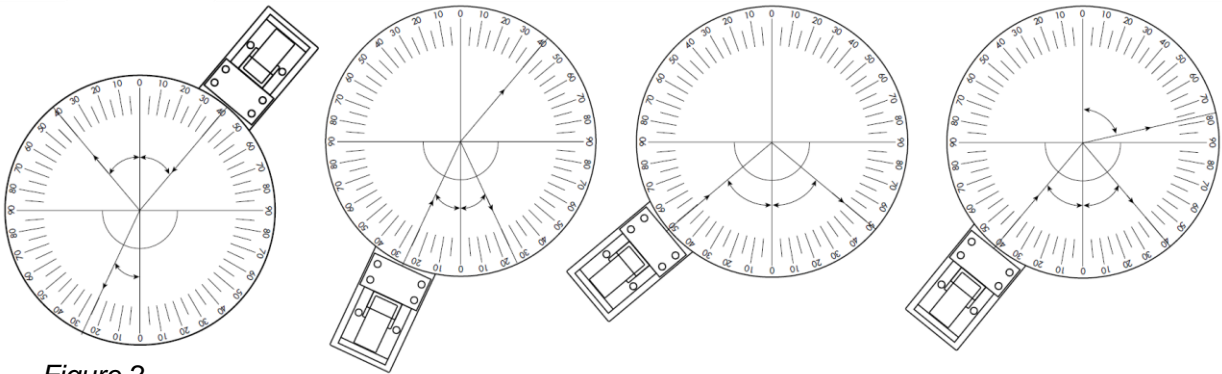

Figure 2

2. Advanced Students can use angle measurements to determine the refraction index for the lens.

Plano-convex Lens Activities:

1. Using the plano-convex lens and the beam splitter, have students observe that this type of lens can focus light onto one point. Have students determine the focal point (F) of the lens (Figure 3).
2. By placing paper (one or two post-it notes work well) on top of the dial face, students can make annotations and trace light rays (Figure 4). Have students experiment a little with this method.
3. Demonstrate how the plano-convex lens magnifies images at close range (inside the focal length). Arrange the upper ray so that it goes directly through the optical center of the lens. Turn the dial face slightly and adjust the lower ray so that it is parallel to the principal axis and crosses the upper ray before entering the lens (Figure 5). Draw a small line AB on the paper from the principal axis to the point at which the upper and lower rays intersect. Now the upper and lower light beams represent two light rays that reflect off of the tip of line AB at point B. In theory, the point at which the two rays intersect after passing through the lens is where the light from the line would fall and where an eye would detect the line. Note that the rays exiting the lens on the opposite

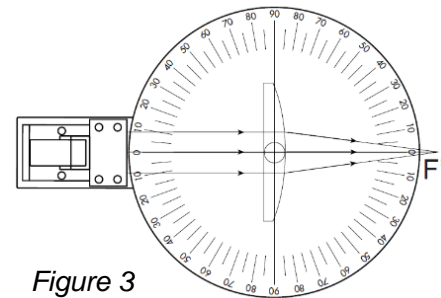

Figure 3

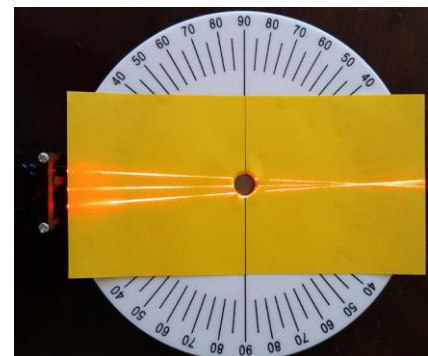

Figure 4

side do not converge. In other words, the eye does not see the object on the opposite side of the lens. Instead, the eye follows the rays back to where it “thinks” they converge on the left side of the lens. By sketching the refracted rays on the paper and then removing the lens, students can continue the lines back towards the left to where they intersect. This intersection represents where light reflected from the top of line AB appear to fall to the eye due to refraction through the lens. Note that line AB would appear larger and farther back than it really is (at A'B' in Figure 5). Therefore, the lens acts as a magnifier. The image A'B' is known as the virtual image, because it does not really exist. It is a function of how our eye perceives the light.

Double Convex Lens Activities:

1. Use the beam splitter to have students locate the optical center of the lens. This is the point at which there is no bending of the light as it passes through the material (Figure 6)
2. Use the beam splitter set to three parallel rays to have students locate the focus (F) of the lens (Figure 7). Advanced students can calculate the focal distance (f) as well as the back focal length (f'). Adjust the beams so that they cross before entering the lens and refract into three parallel beams to find the object focus (Figure 8).
3. Repeat Activity 3c with the double convex lens to determine where the image falls when light reflects off of an object and through the lens. Try this activity with an image (AB) inside the focus of the lens (Figure 9)), at the focal point (Figure 10), and outside the focus of the lens (Figure 11). Is each image a real image or a virtual image? Is it larger or smaller than the original image? Does this lens work as a magnifier?

Students should observe that when an object inside the focal distance (in this case, a line AB) reflects light through the double convex lens, it is seen as an enlarged, virtual image. Objects reflecting light from the focal point will be seen at an infinite position. Objects reflecting light from outside of the focal point will cause a generated real image that is enlarged and inverted.

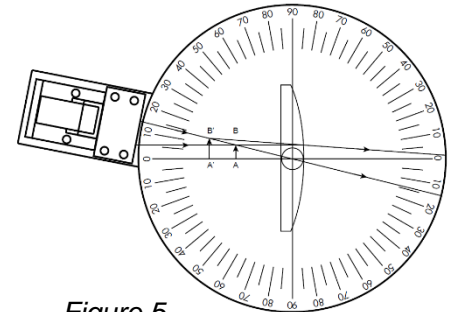

Figure 5

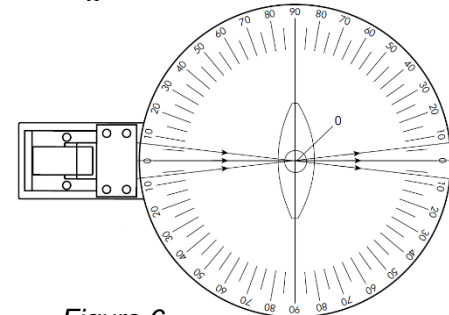

Figure 6

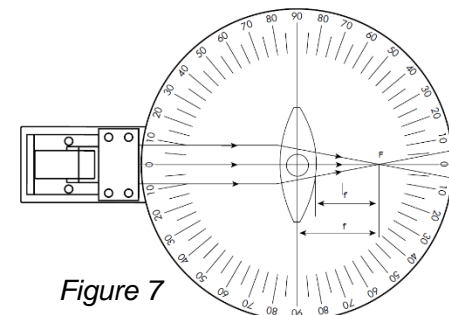

Figure 7

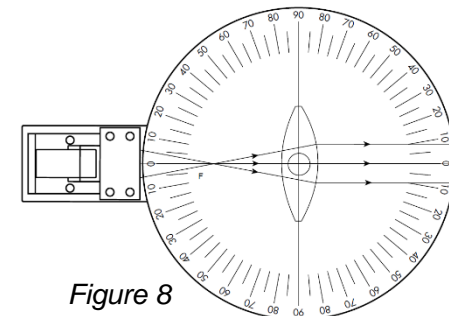

Figure 8

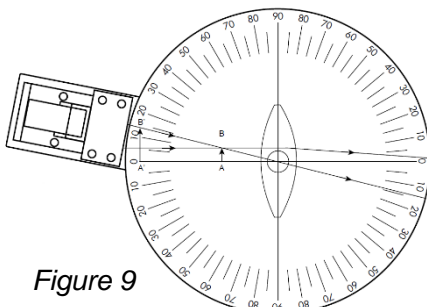

Figure 9

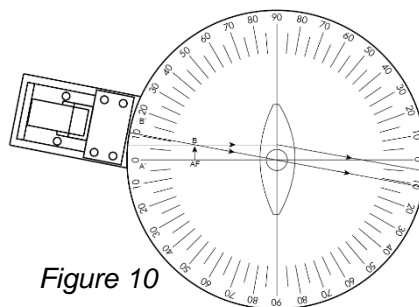

Figure 10

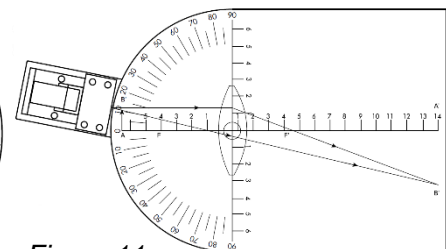

Figure 11

Plano-concave Lens Activities:

1. Use the beam splitter set to three parallel rays to have students observe that the concave plane lens diffuses light rays. Advanced students can trace back the diffused emergent rays to determine the focus (F) (Figure 12).
2. Repeat Plano-convex Activity #3 with the concave plane lens to determine where the image falls when light reflects off of an object and through the lens. Try this activity with an image (line AB) (Figure 13)
3. To create AB, adjust the upper ray so that it passes through the optical center of the lens and the lower ray so that it is parallel to the principal axis. Is the image a real image or a virtual image? Is it larger or smaller than the original image? Is it upright or inverted?

Students should observe that an object (in this case, a line AB) reflects light through the concave plane lens, it is seen as an upright, smaller, virtual image.

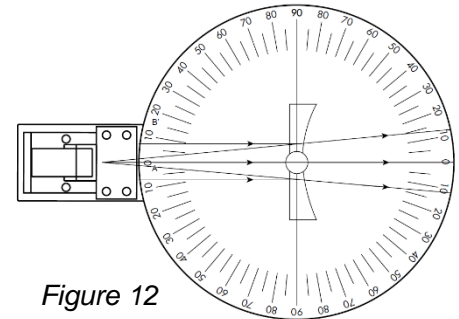

Figure 12

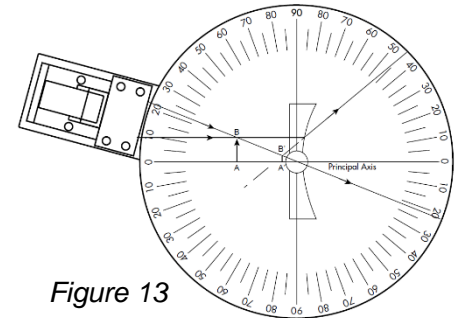

Figure 13

Use Lenses to Demonstration Eyesight Correction:

1. Use the double convex lens to represent the lens of the eye. Ideally, the lens of the eye focuses light on the retina and a message is sent to the brain. In nearsighted individuals (those who have trouble seeing at a distance), the focus falls short of the retina. This condition is also known as myopia. Using the beam splitter, demonstrate three parallel rays of light shining through the double convex lens. Note where the focus falls (where the refracted rays cross). Now place the plano-concave lens in front of the double convex lens (Figure 14). What happens to the focus?
2. In farsighted individuals (those who have trouble seeing close objects), the focus from the lens falls beyond the back of the eye. This condition is also known as hyperopia. Using the beam splitter, repeat step 1 with the plano-convex lens in front of the double convex lens (Figure 15). What happens to the focus?

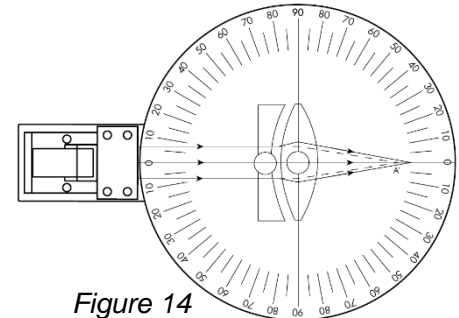

Figure 14

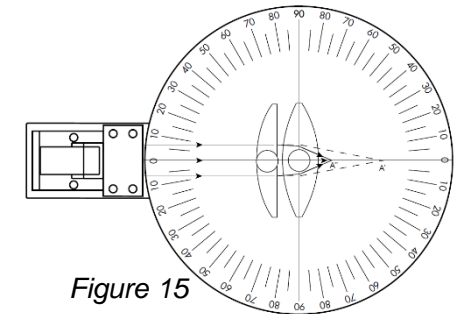

Figure 15

Flat Mirror Activities:

1. Students can experiment with different incident angles and measure reflection angles to determine that the angle of reflection is equal to the angle of incidence (Figure 16).
2. Ask students to look for diffuse reflection, as well. Can they detect it?
3. Substitute other flat materials in place of the mirror to test for reflection. Do all materials that reflect share the same relationship between incident angles and reflection angles? Do some materials demonstrate diffuse reflection more than specular reflection?

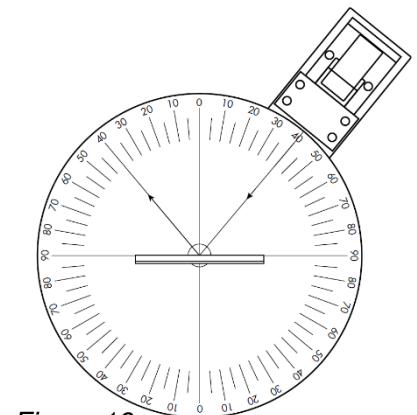

Figure 16

Curved Mirror Activities:

1. Have students determine the center of curvature and focal point for the concave mirror using the splitter and 3 beams of light. It may be helpful to place a post-it note on the dial face by lining up on edge of the paper with the center line. You will need to push the post of the mirror through a bit of the edge of the paper to insert it into the dial face. Now you can draw in the center of curvature (C) and the focal point (F) directly on the paper.

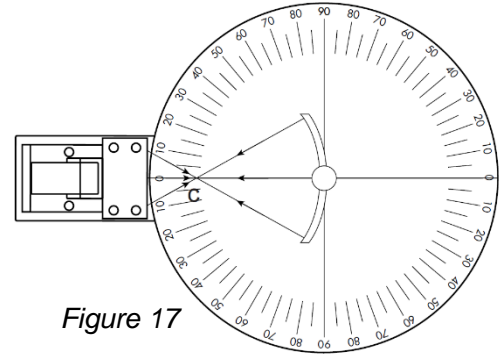

Figure 17

To determine the center of curvature, adjust upper and lower beams so that they cross and reflect directly back upon themselves. The center of curvature is located where all beams of light intersect (Figure 17)

To determine the focal point, adjust all of the beams so that they are parallel. The focal point is where the reflected rays of light intersect. (Figure 18).

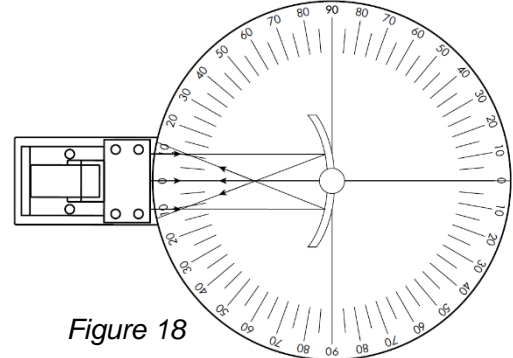

Figure 18

Students can measure the distance from the center of curvature to the mirror (the radius) and the focal length to determine or test the relationship between the two. (focal length = radius/2).

2. Use the concave mirror and the post-it note to experiment with concave mirror optics.

Test the optics of objects located inside the focus (between the focal point and the mirror). Adjust the top light ray so that it is parallel with the optical, or principal, axis. Adjust the lower light ray so that its reflection ray crosses through the focal point. Draw a line from the principal axis to the point where the upper and lower rays intersect. Observe the line in the mirror. How can you use the rays of light to describe the reflection (Figure 19)?

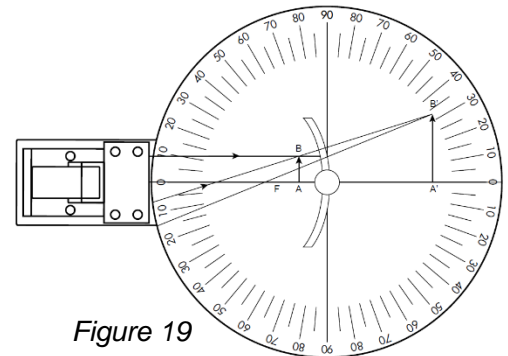

Figure 19

Observe the optics of an object located at the focal point by drawing a thin line perpendicular to the principal axis right at the focal point and up to the upper parallel ray. Observe the line in the curved mirror. It should reflect in the mirror as an infinite line. Adjust the lower light ray to cross through the top of the line. How can the light rays be used to describe the reflection (Figure 20)?

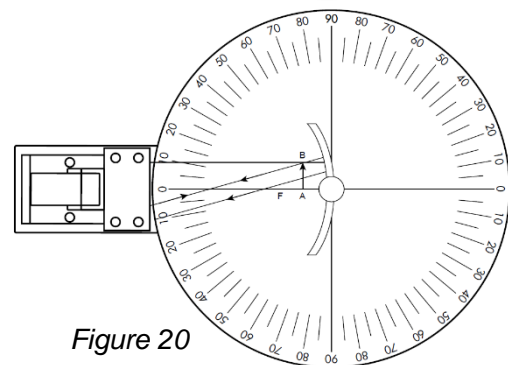
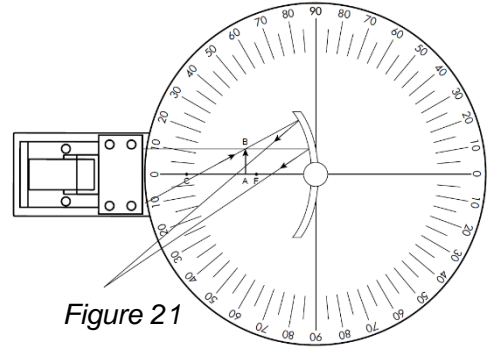

Figure 20

Observe the optics of an object located between the focal point (F) and the center of curvature (C). Between points C and F, draw a perpendicular line between the principal axis and the top light ray (that is adjusted to be parallel to the principle axis). Observe the line in the curved mirror. Where is it located? Adjust the lower light beam to cross through the top of the drawn line. Use the reflected rays to explain your observations (Figure 21).

3. Have students determine the center of curvature and focal point for the convex mirror using the splitter and 3 beams of light. It may be helpful to place two post-it notes on the dial face by lining up on edges of the paper with the center line (one post-it on each side of the mirror). You will need to push the post of the mirror through a bit of the edge of the papers to insert it into the dial face. Now you can draw in the center of curvature (C) and the focal point (F) directly on the paper.



To determine the center of curvature, adjust upper and lower beams so that they cross and reflect directly back upon themselves. The center of curvature is located where all beams of light intersect. You will need to briefly remove the mirror to find the intersection (Figure 22). Is the center of curvature (or the radius of the circle) different than it was for the concave mirror? What might account for the difference? To determine the false focal point, adjust all of the beams so that they are parallel. The false focal point is where the reflected rays of light intersect. This will be on the other side of the mirror. you will need to use a straight edge to mark the reflected rays, then remove the mirror and continue the lines on the other side to find the false focal point (Figure 23).

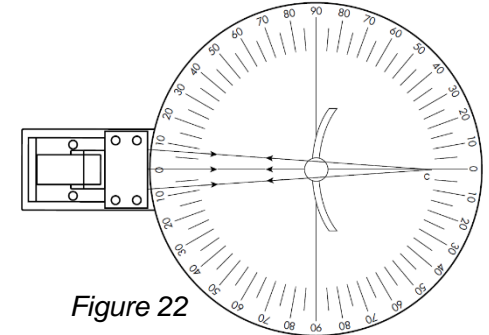

Students can measure the distance from the center of curvature to the mirror (the radius) and the false focal length to determine or test the relationship between the two. (focal length = radius/2).

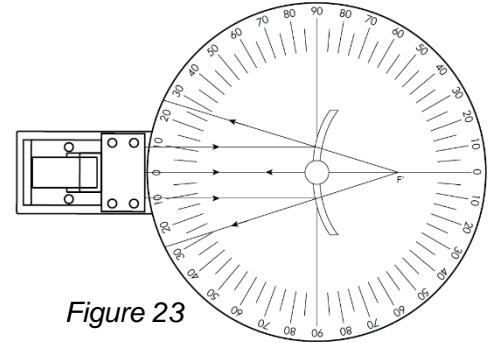

4. Use the convex mirror and the post-it notes to experiment with convex mirror optics.

Lightly sketch a line along the principle axis for reference. Adjust the upper light ray so that it is parallel with the principle axis. Then use the regulator knob on the back of the dial face so that the upper light passes through the center of curvature (so that it reflects directly back along the same line from the curved mirror). Adjust the lower ray so that it is parallel with the principle axis. Draw a perpendicular line from the principal axis to the upper ray. Turn off the laser beams to observe the reflection of the line in the mirror. Then turn the laser beams back on to help you describe the nature of the reflection in much the same way that you used the rays to describe the reflections in the concave mirror (Figure 24).

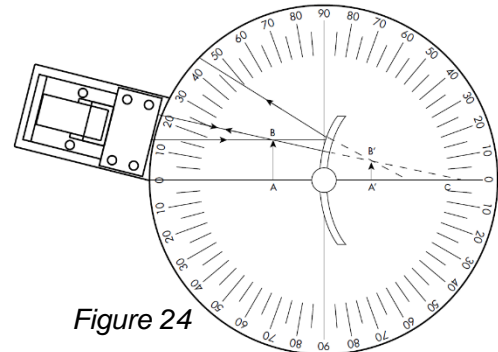

Related Products

Introductory Optical System (92-7700) This simple but elegant Optical System is designed for basic optics experiments, and a great alternative to the traditional mounted optical benches. Students can now easily make the common measurements of image and focal distance with the included lenses, pinhole configurations, and 2-sided screen.

Laser Viewing Tank (P2-7690) Teacher-designed for student exploration of light beams! This versatile system allows students to see and control light beams.

Light Box and Optical Set 2.0 (P2-9580) This affordable Light Box and Optical Set makes it easy to perform experiments involving the optics of lenses, mirrors, and prisms, as well as providing a versatile way to display primary and secondary colors; and both additive and subtractive color mixing.

Laser Ray Box and Lenses (P2-7680) Complete Optics Set uses 1, 3, or 5 Laser Beams! The most complete, economical optics kit you'll find!