

Science Education Manual

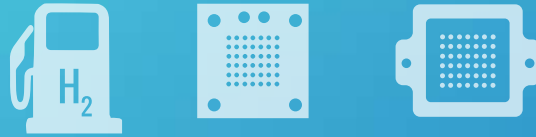

FUEL CELLS



Contents

Fuel Cells

Introduction.....	p.1
1. History of Fuel Cells.....	p.2
2. Fuel Cell Applications.....	p.4
2.1 Stationary Sector.....	p.4
2.2 Transportation Market.....	p.4
2.3 Portable Sector.....	p.4
2.4 Fuel Cells for Automobiles.....	p.5
3. Types of Fuel Cells.....	p.8
3.1 Polymer Exchange Membrane Fuel Cell (PEMFC).....	p.8
3.2 Alkaline Fuel Cells (AFCs).....	p.9
3.3 Phosphoric Acid Fuel Cell (PAFC).....	p.9
3.4 Solid Oxide Fuel Cells (SOFCs).....	p.10
3.5 Molten-Carbonate Fuel Cells (MCFCs).....	p.10
3.6 Direct Methanol Fuel Cells (DMFCs).....	p.11
4. How Do Fuel Cells Work?.....	p.12
4.1 Electrolyte Layer.....	p.13
4.2 Gas Diffusion Layer.....	p.13
4.3 Catalyst Layer.....	p.13
4.4 Bipolar Plates.....	p.14
5. Stack Design and Configuration.....	p.14
6. Operating Conditions.....	p.15
6.1 Polarization Curves.....	p.15
Conclusions.....	p.16

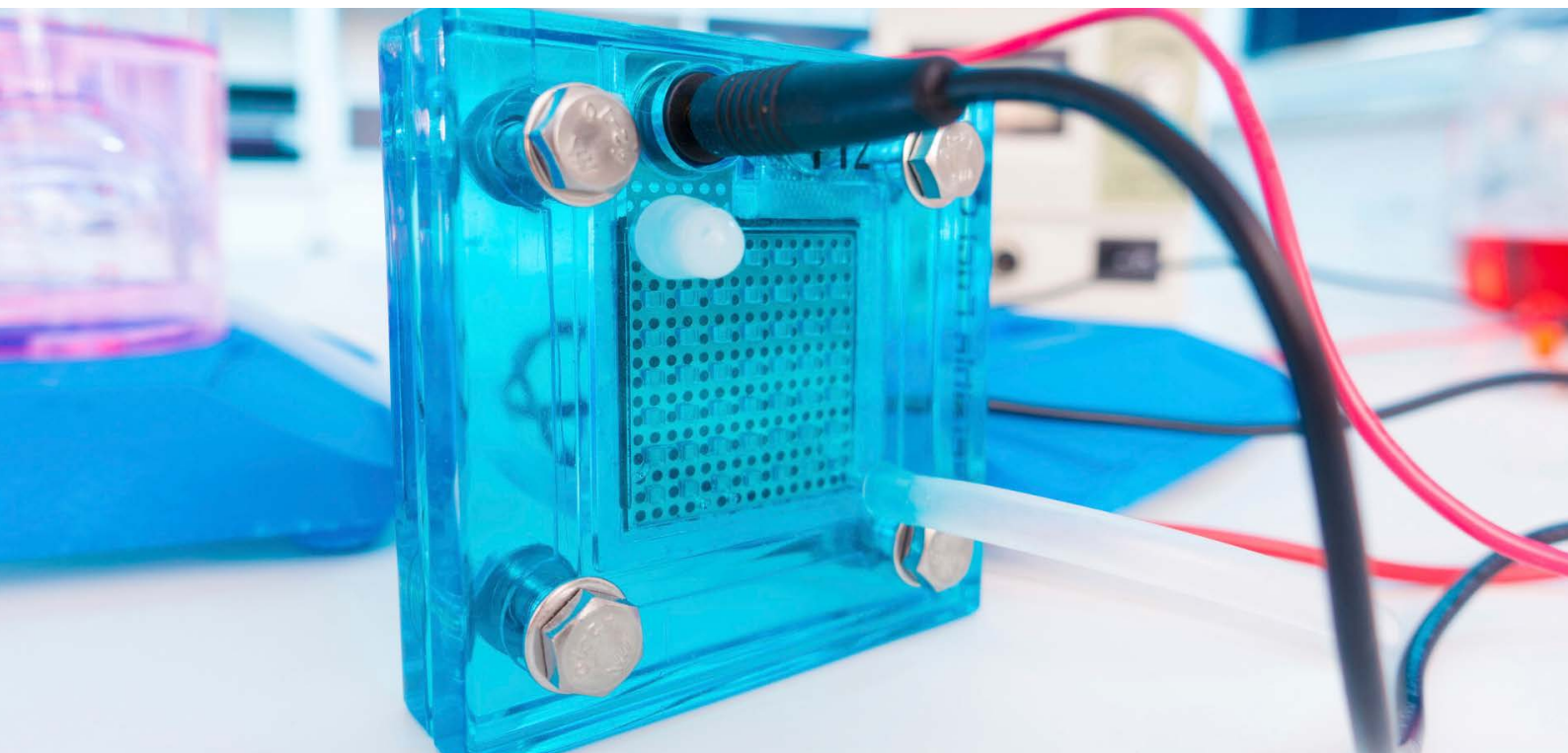

Introduction

Fuel cells will be an integral part of the future hydrogen economy. Fuel cells have the ability to fulfill all of our global power needs while being highly efficient and a low-polluting technology. There are six main types of fuel cells. The type most commonly used for transportation and portable applications is the polymer electrolyte membrane (PEM) fuel cell. PEM fuel cells predominantly use hydrogen as the fuel, but also have the ability to use other types of fuel as well – including ethanol and biomass-derived materials. PEM fuel cells operate at temperatures between 20° and 80 °C, which enable a startup time comparable to the internal combustion engine. PEM fuel cells are able to obtain net power densities of over 1 kW/liter, which makes them competitive with the internal combustion engine for transportation applications.

There are numerous advantages and challenges for PEM fuel cells. Some advantages include:

- ✓ Fuel cells have the potential for a high operating efficiency.
- ✓ There are many types of fuel sources and methods of supplying fuel to a fuel cell.
- ✓ Fuel cells have a highly scalable design.
- ✓ Fuel cells produce no pollutants.
- ✓ Fuel cells are low maintenance because they have no moving parts.
- ✓ Fuel cells do not need to be recharged, and they provide power instantly when supplied with fuel.

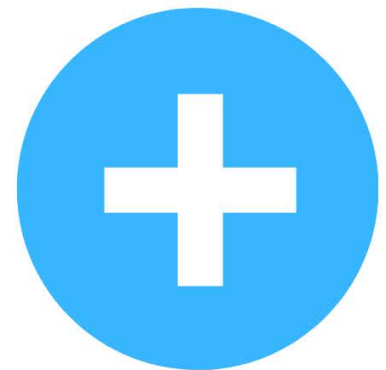

Some limitations common to all fuel cell systems include the following:

- ✓ Fuel cells are costly due to the need for materials with very specific properties. There is an issue with finding low-cost replacements.
- ✓ Fuel reformation technology can be expensive, heavy and requires power in order to run.
- ✓ If another fuel besides hydrogen is fed into the fuel cell, the performance gradually decreases over time due to catalyst degradation and electrolyte poisoning.

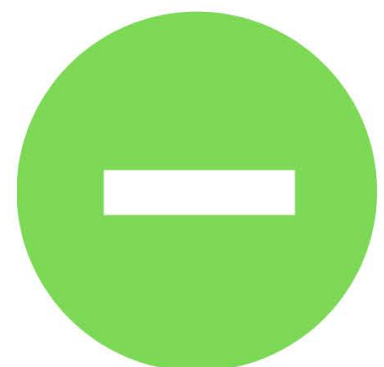

1. History of Fuel Cells

William Grove is credited with inventing the first fuel cell in 1839. Fuel cells were not researched greatly during the 1800s, and much of the 1900s. Extensive fuel cell research began during the 1960s at NASA. During the last decade, fuel cells have been extensively researched, and are finally nearing commercialization. Figure 5-1 summarizes the history of fuel cells.

1800	W. Nicholson & A. Carlisle described the process of using electricity to break water.
1836	Willam Grove fuel cell demonstration.
1889	Separate teams: L. Mond & C. Wright & C. Thompson/ L. Cailleteon & L. Colardeau performed various fuel ce expeiments.
1893	F.ostwald describes roles of fuel cell components.
1896	W. Jaccques constructed a carbon batter .
Early 1900's	E. Baur and students conducted experiments on high temperature devices.
1960s	T. Grubb & L. Niedrach invented PEMFC technology at GE
1990s- Present	Worldwide extensive fuel cell research on all fuel cell types.

William Grove
Known as the Father of Fuel Cells, Grove developed the first cell which furthered fuel cell technology by reversing the electrolysis process in Oxford, England in 1839.

William Nicholson and Anthony Carlisle first described electrolysis in 1800.

Figure 5-1. The history of fuel cells

The process of using electricity to break water into hydrogen and oxygen (electrolysis) was first described in 1800 by William Nicholson and Anthony Carlisle. William Grove invented the first fuel cell in 1839, but using the idea from Nicholson and Carlisle to “recompose water.”He accomplished this by combining electrodes in a series circuit with separate platinum electrodes in oxygen and hydrogen submerged in a dilute sulfuric acid electrolyte solution. The gas battery, or “Grove cell” generated 12 amps of current at about 1.8 volts [10]. Figure 5-2 shows an illustration of Grove’s fuel cell.

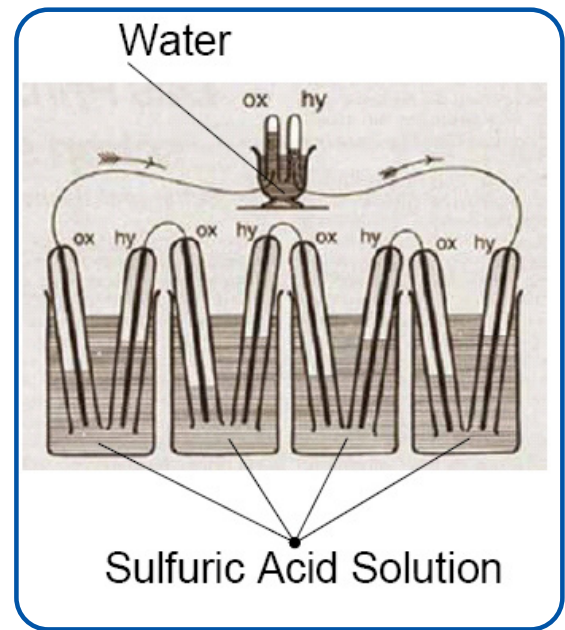

Figure 5-2. Grove's Fuel Cell

One of the founders of physical chemistry, **Friedrich Wilhelm Ostwald** (1853–1932), provided a large portion of the theoretical understanding of how fuel cells operate. In 1893, Ostwald experimentally determined the roles of many fuel cell components. **Ludwig Mond** (1839–1909) was a chemist who spent most of his career developing soda manufacturing and nickel refining. In 1889, Mond and his assistant Carl Langer performed numerous experiments using a coal-derived gas. They used electrodes made of thin, perforated platinum, and had many difficulties with liquid electrolytes. The maximum power they achieved was 6 amps per square foot (the area of the electrode) at 0.73 volts.

Charles R. Alder Wright (1844–1894) and **C. Thompson** developed a similar fuel cell around the same time as Mond and Langer. They had difficulties in preventing gases from leaking from one chamber to another. This and other causes prevented the fuel cell from reaching voltages as high as 1 volt. They felt that if they had received more funding, they would have been able to create a better, robust cell that could provide adequate electricity for many applications.

Louis Paul Cailletet (1832–1913) and **Louis Joseph Colardeau** (France) came to a similar conclusion as Wright and Thompson, but thought the process was not practical due to needing “precious metals.” In addition, many papers were published during this time saying that coal was so inexpensive that a new system with a higher efficiency would not decrease the prices of electricity drastically.

William W. Jacques (1855–1932) constructed a “carbon battery” in 1896. Air was injected into an alkali electrolyte to react with a carbon electrode. He thought he was achieving an efficiency of 82 percent, but actually obtained only 8-percent efficiency.

Emil Baur and students (1873–1944) (Switzerland) conducted many experiments on different types of fuel cells during the early 1900s. His work included high-temperature devices, and a unit that used a solid electrolyte of clay and metal oxides.

Thomas Grubb and **Leonard Niedrach** invented PEM fuel cell technology at General Electric in the early 1960s. GE developed a small fuel cell for the U.S. Navy’s Bureau of Ships (Electronics Division) and the U.S. Army Signal Corps. The fuel cell was fueled by hydrogen generated by mixing water and lithium hydride. It was compact, but the platinum catalysts were expensive.

Based upon the research, development, and advances made during the last century, technical barriers are being resolved by a world network of scientists. Fuel cells have been used for over 20 years in the space program, and the commercialization of fuel cell technology is rapidly approaching.

2. Fuel Cell Applications

Fuel cells would be a beneficial addition to our energy mix because they provide electric power in applications that are currently energy-limited. For example, one of the most annoying things about a laptop computer is that the battery gives out after a couple of hours! Current small fuel cell technology has the potential to power laptops for up to 8 hours at which time a quick recharge of chemicals would allow the user to continue working. Each market needs fuel cells for varying reasons as described in the next few sections.

2.1 Stationary Sector

Large stationary fuel cells can produce enough electricity to power a house or business. These fuel cells may also make enough power to sell back to the grid. Stationary fuel cells are especially advantageous for businesses and residences where no electricity is currently available. In addition, stationary fuel cells can be integrated with solar and wind power devices to create an energy-efficient hybrid power system.

2.2 Transportation Market

The transportation market will benefit from fuel cells because fossil fuels will continue to become scarce, and because of this, there will be inevitable price increases. Legislation around the world is also becoming more diligent about enacting legislation with will control environmental emissions. Many countries are passing laws to reduce emissions, and to sell a minimum number of zero emission vehicles annually. Fuel cell vehicles can offer higher efficiencies than conventional vehicles that are powered by other fuels.

2.3 Portable Sector

One of the primary markets for fuel cells in the future will be in the portable sector. The military also has a need for high-power, long-term devices for troop equipment. There are numerous commercial portable devices that will use fuel cells in order to power the device for longer amounts of time. Some of these devices include laptops, cell phones, video recorders, and iPods. Fuel cells will power a device as long as there is fuel supplied to it. The current trend in electronics is the convergence of devices, and the limiting factor of many new devices is the amount of power that it requires. Therefore, power sources, such as fuel cells, that can supply greater power for a longer period of time will allow the development of new, multifunctional devices.



Figure 5-2. Horizon MiniPak Portable Electronics Charging Unit

2.4 Fuel Cells for Automobiles

Most automobile manufacturers have been developing fuel cell vehicles for at least a decade, and have demonstrated at least one prototype vehicle. The major reasons for developing automotive fuel cell technology are their efficiency, low or zero emissions, and fuel that could be reproduced from local sources rather than imported.

Automotive fuel cells can have one or all of the following characteristics:

- ✓ **A fuel cell is sized to provide all of the power to a vehicle.**
- ✓ **A battery may be present for startup.**
- ✓ **A fuel cell typically supplies a constant amount of power, so for vehicle acceleration and other power spikes, additional devices are typically switched on such as batteries, ultra or supercapacitors, and so on.**
- ✓ **Sometimes a fuel cell is used as the secondary power source. A system is set up where batteries power the vehicle, and the fuel cell just recharges the batteries when needed.**
- ✓ **A fuel cell can run part or all of the vehicle's electrical system.**

The operating temperature of the fuel cell stack for an automobile ranges from 60 to 80 °C. Operating temperatures above 100 °C would improve the heat transfer and simplify stack cooling, but most automotive fuel cells use PEMFCs (proton exchange membrane fuel cells) or DMFCs (direct methanol fuel cells) which are limited the operation to temperatures below 100 °C due to water management issues in the device. The main components of a fuel cell system are shown in Figure 5-3.

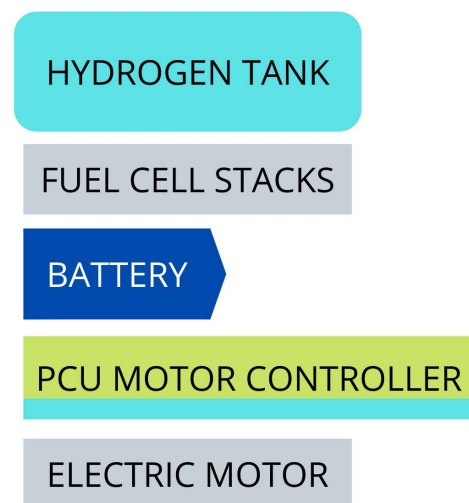
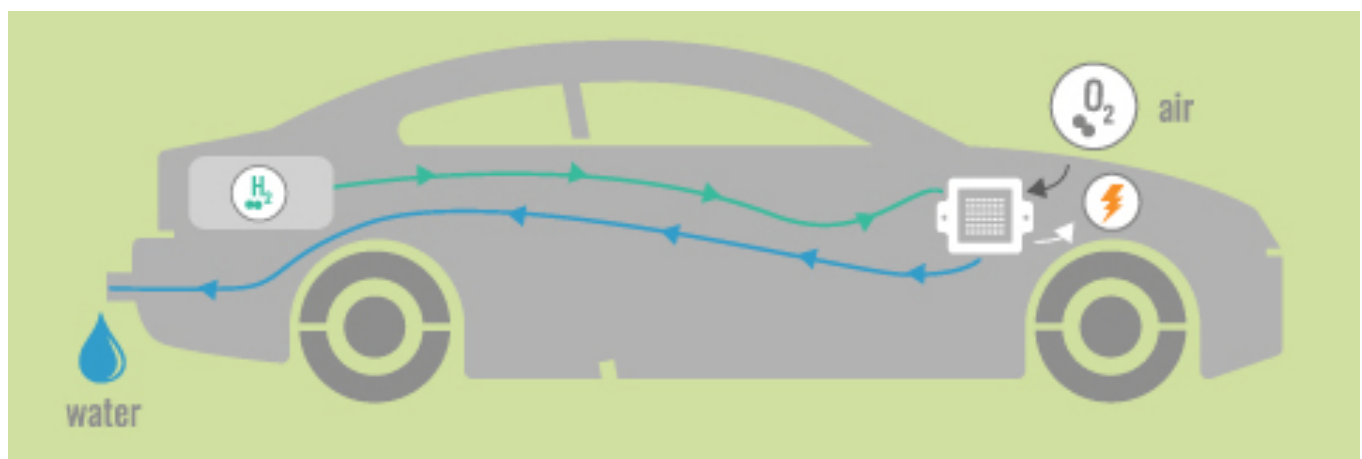
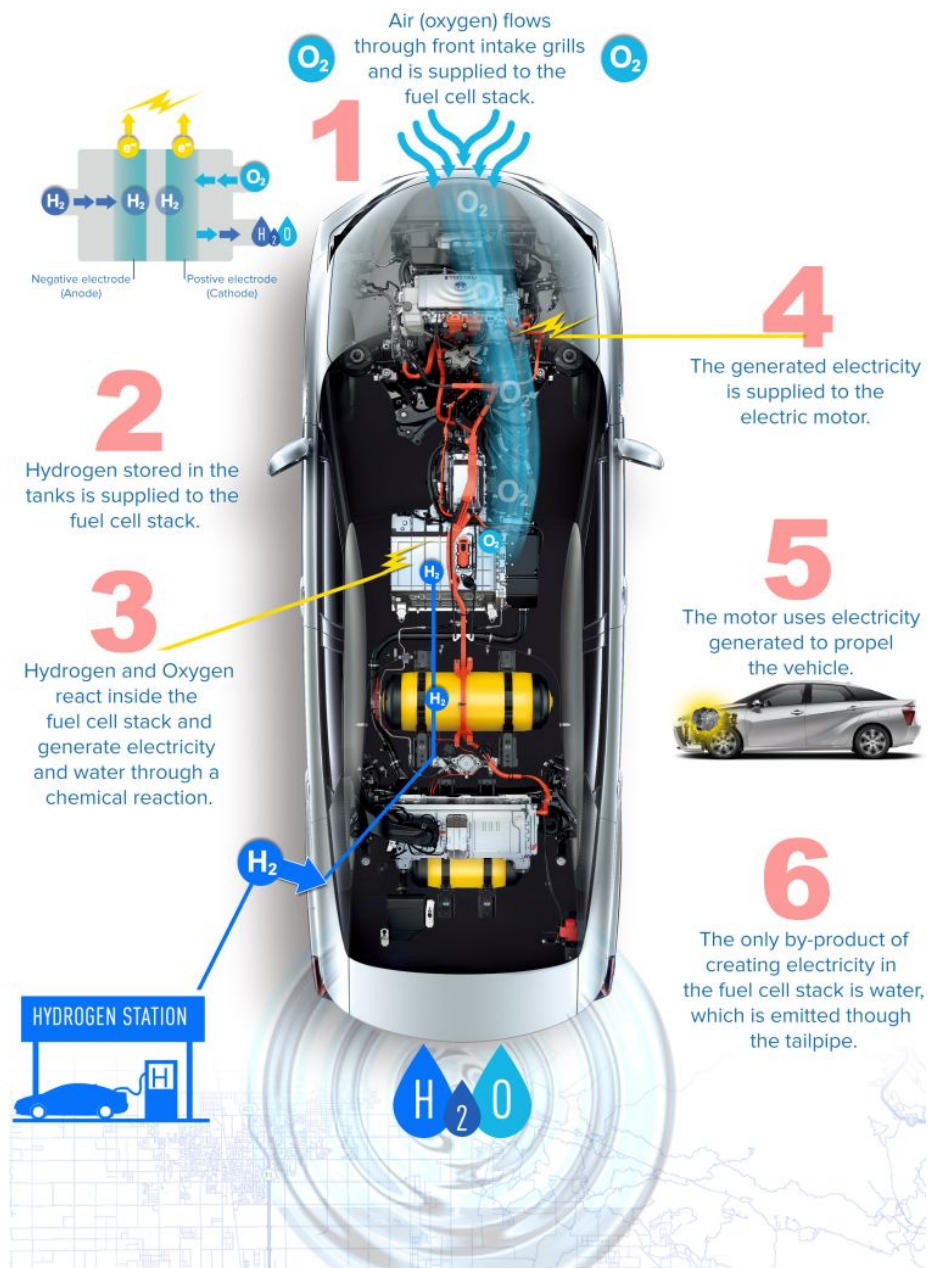

Figure 5-3. Hydrogen Fueled Fuel Cell Vehicle



The design of a fuel cell as a power source in transportation applications involves a number of parameters. These include the same power requirement as with any conventional power source, weight and size of the fuel cell, electric motor and power electronics, the type of fueling system, and the distance between fueling and the time it takes to refuel. The fuel cell allows automotive engineers to employ completely non-traditional concepts in vehicle design. One such design is the General Motors Fuel Cell Car with the skateboard design. Fueling options include on-board production of hydrogen from conventional fuels, and on-board hydrogen storage with home or standard refueling stations. The US Department of Energy has opted to only support on-board hydrogen storage. Home refueling stations may employ reformation of hydro-carbon fuels or electrolysis of water.

When designing a fuel cell for automobile (or any other vehicle type), there are many forces that affect a vehicle and the fuel system. The vehicle engine needs to provide enough power to overcome these forces to move the vehicle. A free body diagram is created to understand the forces acting on an object. The forces must be balanced if an object remains at rest. If the forces are not balanced, then the object will move.



HOW DOES TOYOTA'S FUEL CELL VEHICLE WORK?

Blog Toyota

The effect of the forces on an object is dependent upon the forces acting on the object, and its surroundings. Common forces include weight, resisting force, friction, air resistance or drag and driving force. The weight of an object is the force created by gravity acting on the object's mass. The resisting force is a force that equals the weight of an object in the opposite direction. Friction occurs when two objects contact one another, and slide against each other. Air resistance or drag is a result of the air flow on an object. The air flow will be different if the shape, velocity and object roughness varies. The driving force is the force that moves an object. This force must overcome other forces that are holding it in place. These forces are mathematically explained by Newton's law of motion, which includes the concepts of mass, force and acceleration.

The first law states that an object in motion stays in motion, and an object at rest stays at rest unless a force causes it to move. The second law relates mass to force:

$$F = ma$$

where F is the force acting on an object, m is the mass of the object and a is the acceleration of the object due to the force acting on an object. If the acceleration acting on an object is due to gravity, a "g" is substituted for the "a" in the equation to get:

$$F = mg = W$$

where g is the gravitational acceleration. When the acceleration is due to gravity the force, F, now becomes the weight of an object.

Newton's third law states, for every action, there is an equal and opposite reaction.

A free body diagram of a vehicle is shown in Figure 5-4.

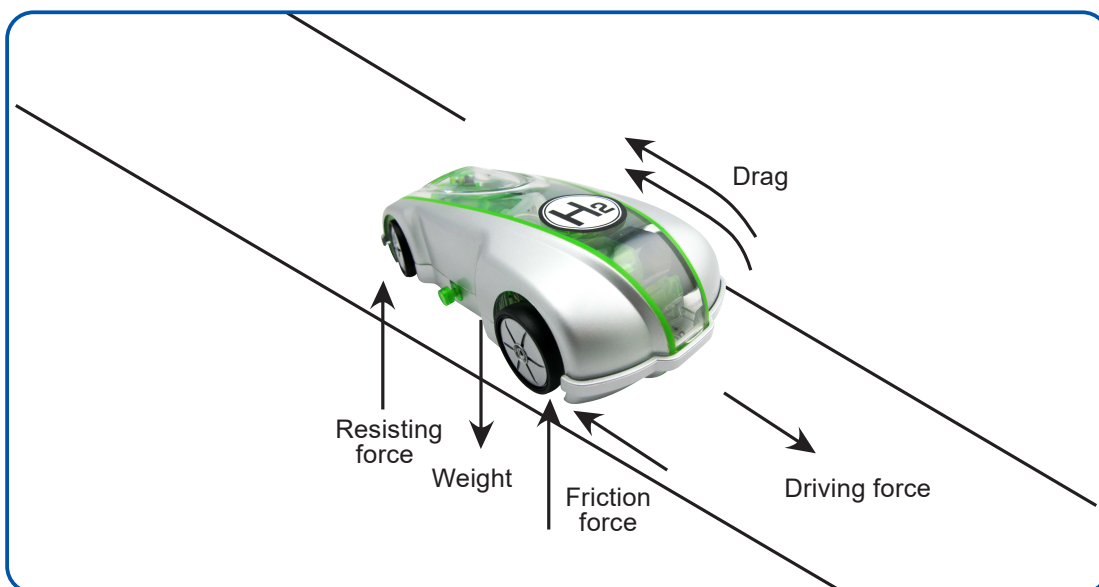

Figure 5-4: Free-body diagram of an automobile

These forces must have a sum of zero if the vehicle is to maintain a constant velocity. If the vehicle needs to accelerate, the net forward acceleration times the mass can provide a quick estimate. The various power demands can be summarized for a total mechanical power demanded by the motion of the vehicle.

3. Types of Fuel Cells

Many types of fuel cells are currently being researched. The six primary types of fuel cells are differentiated from one another on the basis of the electrolytes and/or fuel used with that particular type of fuel cell. The operating temperature and size of fuel cells are often the determining factor is which fuel cell will be used for specific applications.

Fuel cell types include the following:

- ✓ **Polymer electrolyte membrane fuel cells (PEMFCs)**
- ✓ **Alkaline fuel cells (AFCs)**
- ✓ **Phosphoric acid fuel cells (PAFCs)**
- ✓ **Solid oxide fuel cells (SOFCs)**
- ✓ **Molten carbonate fuel cells (MCFCs)**
- ✓ **Direct methanol fuel cells (DMFCs)**

3.1 Polymer Exchange Membrane Fuel Cell (PEMFC)

The polymer electrolyte membrane (also called proton exchange membrane or PEM) fuel cell delivers high-power density while providing low weight, cost, and volume. A PEM fuel cell consists of a negatively charged electrode (anode), a positively charged electrode (cathode), and an electrolyte membrane, as shown in Figure 5-5. It is a very similar configuration to the bipolar-type electrolyzers in Chapter 4. Hydrogen is used on the anode side, and oxygen is utilized on the cathode. Protons are transported from the anode to the cathode through the electrolyte membrane and the electrons are carried over an external circuit load. A typical PEM fuel cell has the following reactions:

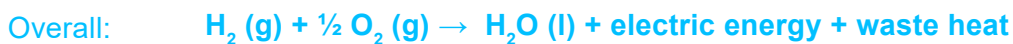
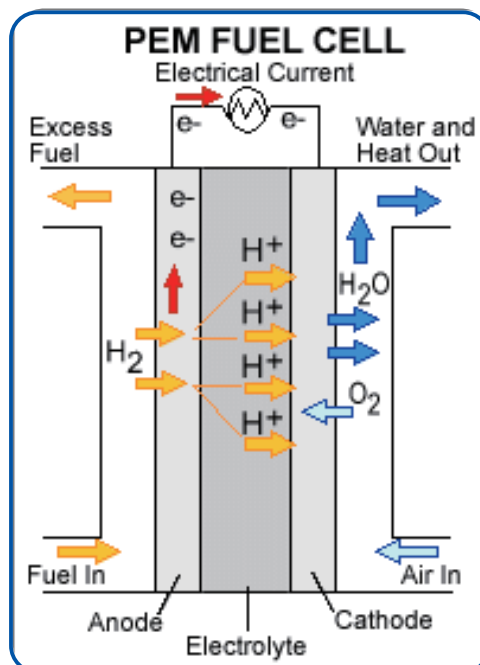

Figure 5-5. PEM Fuel cell



3.2 Alkaline Fuel Cells (AFCs)

Alkaline fuel cells (AFCs) have been used by NASA on space missions and can achieve power-generating efficiencies of up to 70 percent. The operating temperature of these cells range between 150 to 200 °C (about 300 to 400 °F). An aqueous solution of alkaline potassium hydroxide soaked in a matrix act as the electrolyte. This is advantageous because the cathode reaction is fast in the alkaline electrolyte, which means higher performance. Several companies are examining ways to reduce costs and improve operating flexibility. Alkaline fuel cells typically have a cell output from 300 watts to 5 kW. An illustration of an alkaline fuel cell is shown in Figure 5-6. The chemical reactions that occur in this cell are:

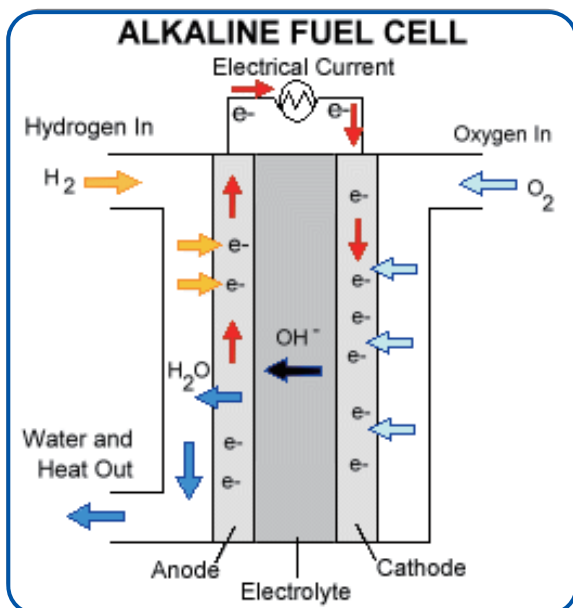
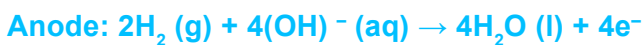

Figure 5-6. An alkaline fuel cell (AFC)

3.3 Phosphoric Acid Fuel Cell (PAFC)

The phosphoric acid fuel cell (PAFC) is one of the few commercially available fuel cells. Several hundred fuel cell systems have been installed all over the world. Most of the PAFC plants that have been built are in the 50 to 200 kW capacity range, but large plants of 1 MW and 5 MW have been built. The largest plant operated to date achieved 11 MW of grid-quality alternating current (AC) power. A PAFC is shown in Figure 5-7.

PAFCs are very efficient fuel cells, generating electricity at more than 40 percent efficiency. Operating temperatures are in the range of 300 to 400 °F (150 to 200 °C) [10]. The PAFC is a poor ionic conductor at lower temperatures, and carbon monoxide (CO) poisoning of the platinum catalyst in the anode can become severe.

The chemical reactions for PAFCs are as follows:

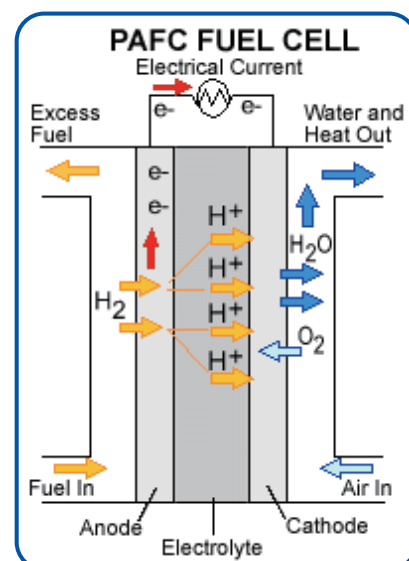

Figure 5-7. A phosphoric acid fuel cell (PAFC)

3.4 Solid Oxide Fuel Cells (SOFCs)

Solid oxide fuel cells (SOFCs) seem promising for large, high-power applications such as industrial and large-scale central electricity generating stations. A solid oxide system is usually constructed of a hard ceramic material consisting of solid zirconium oxide and a small amount of Ytria, instead of a liquid electrolyte.

See Figure 5-8 for an illustration of a solid oxide fuel cell. The operating temperatures can reach 1,800 °F or 1000 °C [10]. Power-generating efficiencies could reach 60 to 85 percent with cogeneration and when cell output is up to 100 kW [10]. The anode, cathode, and overall cell reactions are:

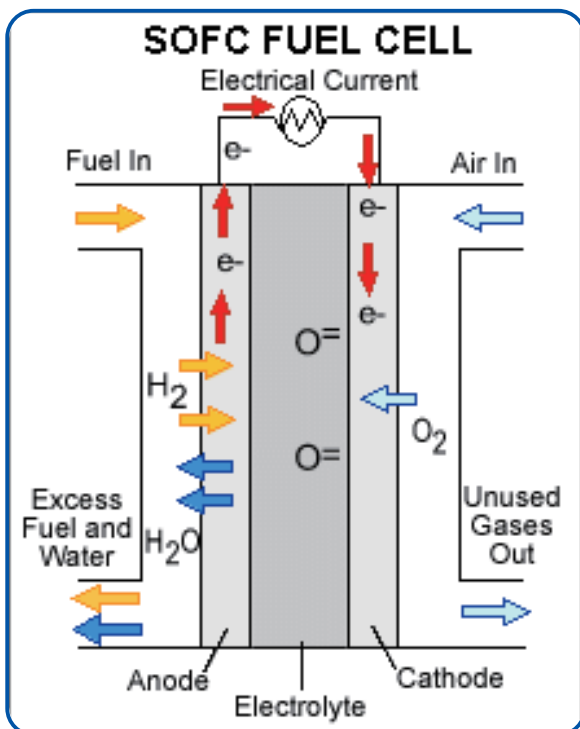
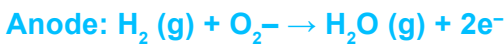

Figure 5-8. A solid oxide fuel cell (SOFC)

3.5 Molten-Carbonate Fuel Cells (MCFCs)

Molten carbonate fuel cells are another fuel cell technology that has been successfully demonstrated in several locations throughout the world. The high operating temperature offers a significant advantage because it enables a higher efficiency and the flexibility to use more types of fuels and inexpensive catalysts. A disadvantage of MCFCs is that high temperatures enhance corrosion and the breakdown of cell components. The electrolyte in the molten-carbonate fuel cell is a liquid solution of lithium, sodium, and/or potassium carbonates, soaked in a matrix. MCFCs have high fuel-to-electricity efficiencies ranging from 60 to 85 percent with cogeneration, and operate at about 1,200 °F or 650 °C [10].

Cogeneration:

A process that uses waste energy to produce heat or electricity.

This high operating temperature is needed to achieve sufficient conductivity of the electrolyte. These high temperatures also allow cheaper catalysts for the cell's electrochemical oxidation and reduction processes. Figure 5-9 shows an example of a MCFC.

Molten carbonate fuel cells can use hydrogen, carbon monoxide, natural gas, propane, landfill gas, marine diesel, and coal gasification products. MCFCs producing 10-kW to 2-MW MCFCs has been tested on a variety of fuels and is primarily targeted to electric utility applications. The reactions at the anode, cathode, and the overall reaction for the MCFC are:



Overall:



3.6 Direct Methanol Fuel Cells (DMFCs)

The large potential market for fuel cell portable applications has generated a strong interest in a fuel cell that can run directly on methanol. The direct methanol fuel cell (DMFC) uses the same polymer electrolyte membrane as the PEM fuel cell. The fuel for the DMFC, however, is methanol instead of hydrogen. Methanol flows through the anode as fuel and is broken down into protons, electrons, water, and carbon dioxide. Advantages of methanol include its wide availability and its ability to be easily reformed from gasoline or biomass. Although it only has a fifth the energy density of hydrogen by weight, since it is liquid it offers more than four times the energy per volume when compared to hydrogen at 25 atmospheres. The chemical reactions for this fuel cell are as follows:

Anode:

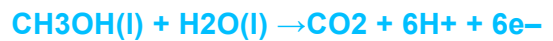

Cathode:



Overall:

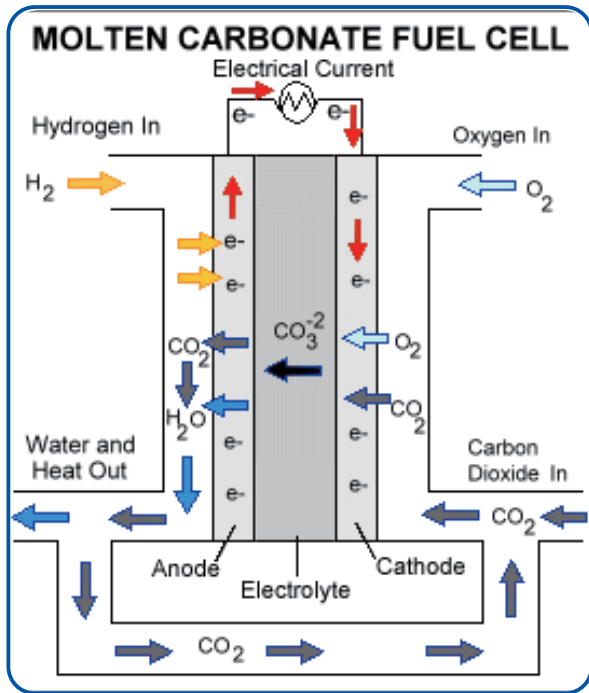

Figure 5-9. A molten carbonate fuel cell (MCFC)

4. How Do Fuel Cells Work?

A single fuel cell operates at a voltage ranging from 0.6 – 0.8 V, and produces a current per active area (**current density**) of 0.2 to 1 A/cm². A fuel cell consists of a negatively charged electrode (**anode**), a positively charged electrode (**cathode**), and an electrolyte. Hydrogen is oxidized on the anode and oxygen is reduced on the cathode. Protons are transported from the anode to the cathode through the electrolyte, and the electrons are carried to the cathode over an external circuit. Electrons are transported through conductive materials and travel to the load when needed. Both, the anode and cathode, contain a catalyst to create electricity from the electrochemical process as shown in Figure 5-10.

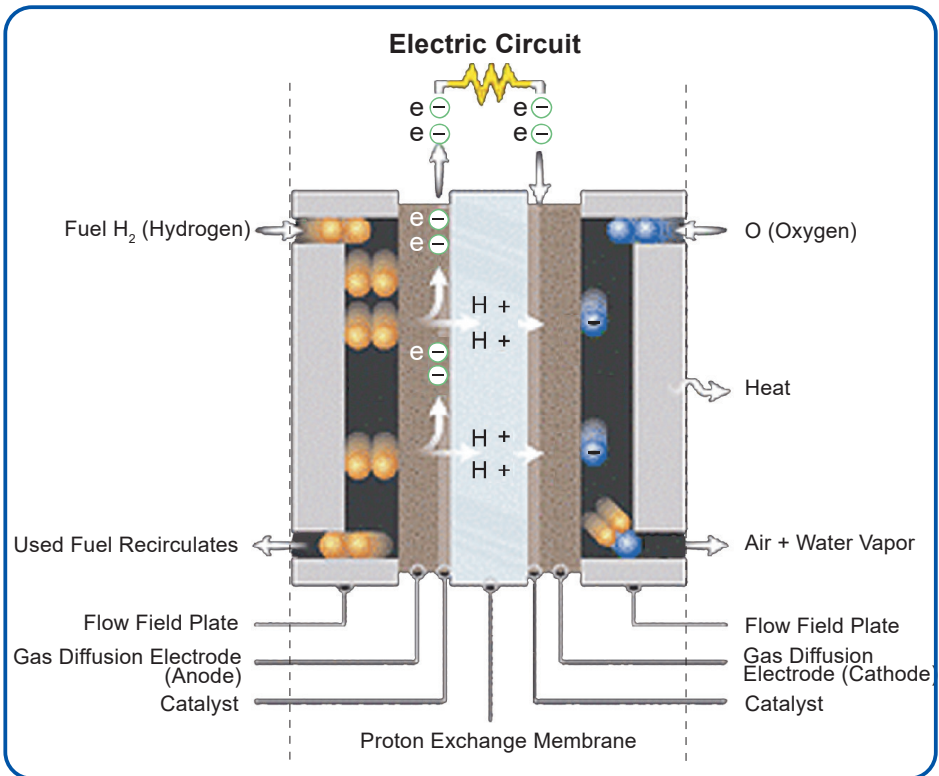

Figure 5-10. A Single PEM Fuel Cell .

The conversion of the chemical energy of the reactants to electrical energy, heat, and liquid water occurs in the catalyst layers. The fuel and oxidant travel to the catalyst layers where the electrochemical reactions take place. The water and waste heat generated by the fuel cell must be continuously removed, and may present critical issues for fuel cells.

Because most applications have voltage or power requirements that cannot be satisfied by a single cell, a number of cells are connected in series to make a fuel cell stack. These repeating cells are separated by flow field plates. Increasing the number of cells in the stack increases the voltage, while increasing the surface area of the cells increases the current. A PEM fuel cell stack is made up of bipolar plates, membrane electrode assemblies (MEA), and end plates as shown in Figure 5-11.

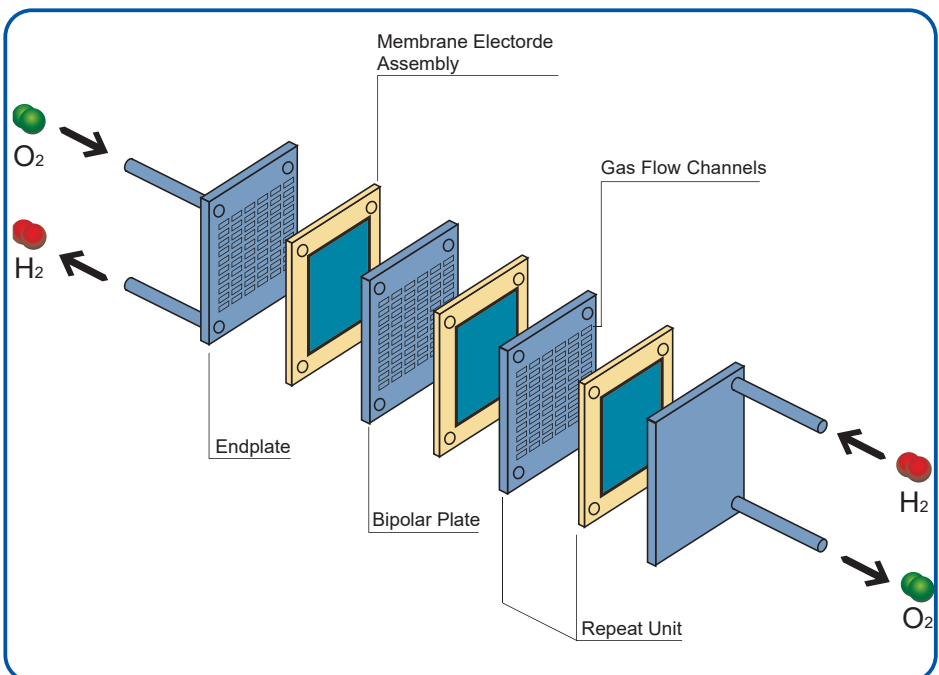

Figure 5-11. An Exploded View of a Polymer Electrolyte Membrane Fuel Cell Stack.

The bipolar plates are constructed of graphite or metal, and they simultaneously distribute gases through flow channels to the fuel cell layers (MEA) while transporting electrons to the load. Gas flow channels allow the anode and cathode reactants to enter the MEA, where the electrochemical reactions occur. In a PEM fuel cell, the MEA typically has a thickness of 500 – 600 μm , and consists of five layers: the proton exchange membrane, two anode and cathode catalyst layers and two anode and cathode gas diffusion layers. These fuel cell layers are described in more detail in the next few sections.

4.1 Electrolyte Layer

The electrolyte layer is the heart of a fuel cell. It enables the fuel cell to conduct its electrons properly by attracting the protons, and enabling them to travel through the layer while maintaining their proton state. The electrons travel to the external circuit to power the load, and the hydrogen protons travel through the electrolyte until they reach the cathode to combine with oxygen to form water. The electrolyte must be able to conduct ions well; it must present a good enough barrier to not allow other reactants to enter it; it must not conduct electrons; and it has to be easy to integrate into the fuel cell stack.

4.2 Gas Diffusion Layer

The gas diffusion layers (GDL) have two main functions: they must allow gases to pass through them, and be conductive enough to allow electrons to travel through them. These layers also provide a layer to bond the catalyst to, and its structure promotes the removal of water that may get in the way of the reaction. This layer is very thin, with a thickness of 0.25 – 0.40 mm, and a pore size ranging between 4 – 50 microns .

4.3 Catalyst Layer

The fuel cell reactions occur in the catalyst layer. The anode catalyst layer breaks the hydrogen fuel into protons and electrons, and at the cathode catalyst layer, oxygen combines with the protons to form water. These catalyst layers are often the thinnest layer in the fuel cell (5 to 30 μm), but are often the most complex because they incorporate several types of gases and water and electrochemical reactions. The catalyst layers are usually made of a porous mixture of carbon supported platinum or platinum/ruthenium.

The reactions in the catalyst layers are **exothermic**; therefore, heat must be transported out of the cell. The heat can be removed through the convection in the flow channels and conduction in the solid portion of the catalyst layers, gas diffusion media, and bipolar plates. Since liquid water is produced by the PEM fuel cell, the condensation and evaporation of water affects the heat transfer in a PEM fuel cell. Therefore, the water and heat management in the fuel cell are closely linked.

4.4 Bipolar Plates

Bipolar plates evenly distribute fuel and oxidant to the cells, and collect the current to power the desired devices. In a fuel cell with a single cell, there are no bipolar plates (only single-sided flow field plates). Yet, in fuel cells with more than one cell, there is usually at least one bipolar plate (flow fields exist on both sides of the plate). Bipolar plates perform many roles in fuel cells. They distribute fuel and oxidant within the cell, separate the individual cells in the stack, collect the current, carry water away from each cell, humidify gases, and keep the cells cool. Bipolar plates also have reactant flow channels on both sides, forming the anode and cathode compartments of the unit cells on the opposing sides of the bipolar plate. Commonly used designs can include straight, serpentine, parallel, interdigitated or pin-type flow fields as shown in Figure 5-12. Materials are chosen based upon chemical compatibility, resistance to corrosion, cost, density, electronic conductivity, gas diffusivity/impermeability, manufacturability, stack volume/kW, material strength, and thermal conductivity.

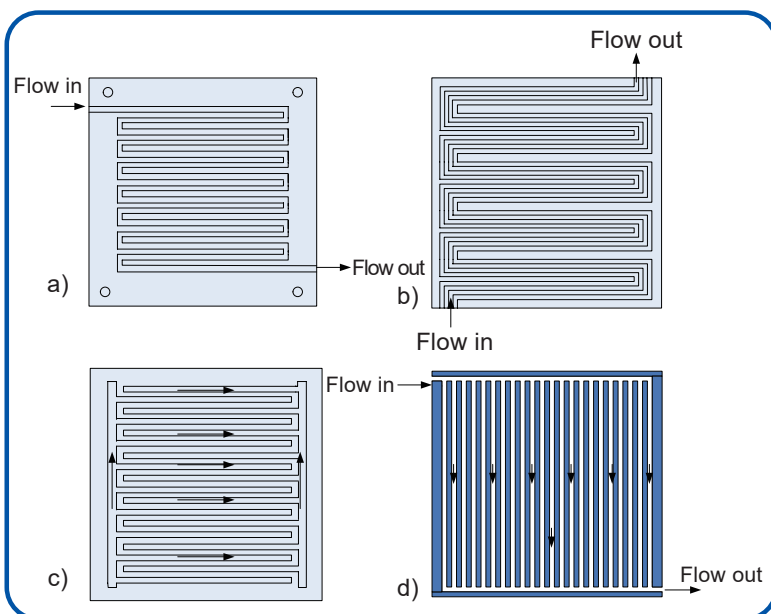

Figure 5-12. (a) Serpentine Flow Field Design, (b) Multiple Serpentine Flow Channel Design, (c) A Parallel Flow Field Design, (d) Interdigitated Flow Channel Design [10]

5. Stack Design and Configuration

In the traditional bipolar stack design, the fuel cell stack has many cells in series, and the cathode of one cell is connected to the anode of the next cell. The MEAs, gaskets, bipolar plates and end plates are the typical layers of the fuel cell. The cells are usually clamped together. The most common fuel cell configuration is shown in Figure 5-13. Each cell (MEA) is separated by a plate with flow fields to distribute the fuel and oxidant. The majority of fuel cell stacks are of this configuration regardless of fuel cell size, type or fuel used.

Fuel cell performance is dependent upon the flow rate of the reactants. Uneven flow distribution can result in uneven performance between cells. Reactant gases need to be supplied to all cells in the same stack through common manifolds.

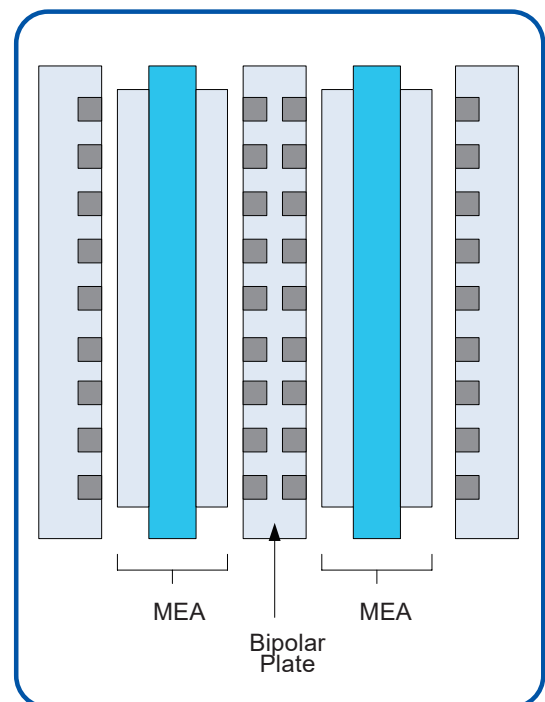

Figure 5-13. Typical Fuel Cell Stack Configuration (a two-cell stack) [11]

6. Operating Conditions

One of the advantages of fuel cell technology is that it has a wide range of operating conditions. This means that many fuel cells can operate at room temperature for certain applications, and others can run at higher temperatures in systems where it is advantageous. Fuel cell performance is determined by the pressure, temperature, and humidity during operation of the application. Performance can often be improved (depending upon fuel cell type) by increasing the temperature, pressure, humidity and optimizing other important fuel cell variables. The ability to increase these variables is application-dependent, because system issues, weight and cost play important factors when optimizing certain parameters.

6.1 Polarization Curves

The traditional measure of characterizing a fuel cell is through a polarization curve – which is a plot of cell potential versus current density. This curve was first introduced in Chapter 4. An I-V curve is the most common method for characterizing and comparing fuel cell efficiency to other published data. The polarization curve illustrates the voltage-current relationship based upon operating conditions such as temperature, humidity, applied load, and fuel/oxidant flow rates. Figure 5-14 shows a typical polarization curve for a single PEM fuel cell, and the regions of importance.

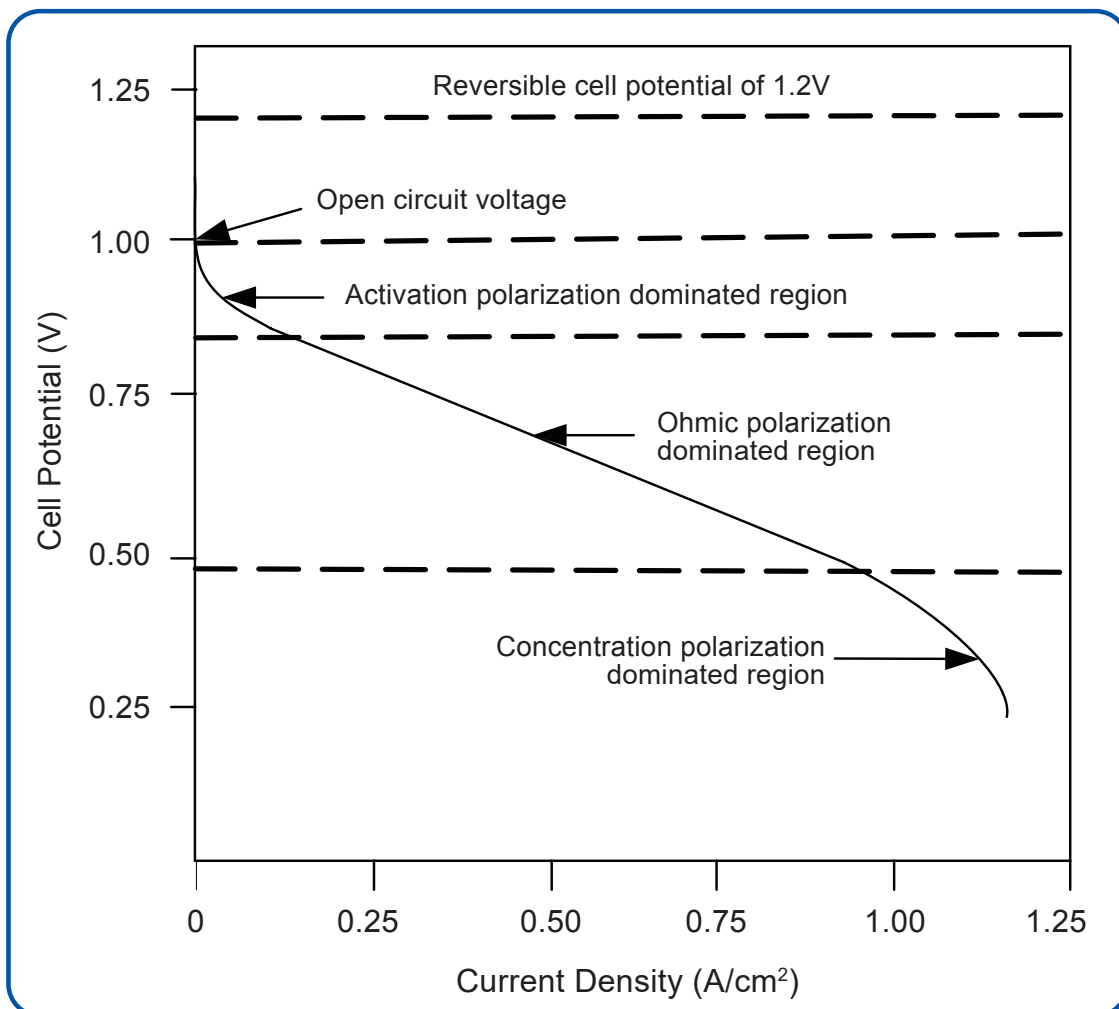

Figure 5-14. Example of a PEMFC Polarization Curve.

As shown in Figure 5-14, the polarization curve can be divided into three regions: (1) the activation overpotential region, (2) the ohmic overpotential region, and (3) the concentration overpotential region. In the activation overpotential region, voltage losses occur when the electrochemical reactions are slow to produce current. The oxygen electrochemical reaction on the cathode is responsible for most of the activation overpotential. As the PEM fuel cell produces more current, the activation losses increase at a slower rate than the ohmic losses. The ohmic overpotential is due to the resistance of the transport of charged species in the polymer electrolyte membrane, catalyst and gas diffusion layers and bipolar plates. The concentration overpotential is due to [mass transport limitations](#); the rates of the electrochemical reactions within the catalyst layers are hindered by a lack of reactants. The mass transport limitations are due to both diffusional limitations in the electrode backing layer and water flooding in the cathode catalyst layer. At high current densities, the amount of liquid water produced in the cathode catalyst layer becomes greater than the amount of water that can be removed from the flow in the gas channels. For further details on these voltage losses, please see Chapter 4.

Conclusions

This chapter covered how fuel cells will be an essential part of the future renewable energy economy. They have the ability to fulfill all of our power needs in the stationary, transportation and portable power industry. There are six main types of fuel cells: PEMFCs, AFCs, PAFCs, SOFCs, MCFCs, and DMFCs. The type most commonly used for transportation and portable applications is the polymer electrolyte membrane (PEM) fuel cell. PEM fuel cells typically use hydrogen as the fuel, but also have the ability to use other types of fuel as well – including ethanol and biomass-derived materials. Fuel cells are made up five main layers: two gas diffusion layers, two catalyst layers and an electrolyte. The two gas diffusion layers are made of a conductive carbon cloth that is porous. The catalyst layers are a mixture of porous platinum and carbon. The fuel cell electrolyte determines many other parameters in the fuel cell system, such as: reaction chemistry, operating temperatures, cell materials, and cell and stack designs. The differences lead to important characteristics, advantages, and disadvantages of each fuel cell type. Any of the fuel cell types can be used in conjunction with a hybrid energy system. Solar, wind, electrolysis and power electronics can be part of an ideal hybrid energy system.

**ARE YOU READY TO BUILD
YOUR OWN FUEL CELL CAR ?**

LET'S DO IT!



Science Education Manual

Chapter 2:

Fuel Cells

Dr. Colleen Spiegel
edited by Matthew Williams

CREDITS

Contributors/Reviewers
Colleen Spiegel Ph.D.

Horizon Design and Production Staff
Stone Shen, Miro Zhang, Dane Urry

Copyright © 2020 by Horizon Educational.

All rights reserved. No part of this publication may be reproduced or transmitted in any form or by any means, electronic or mechanical, including photocopy, recording, or any information storage and retrieval system, without permission in writing from the publisher.

Horizon Educational

<http://www.horizoneducational.com/>