

Physics Workshop

Teacher's Notes

Pendulum Motion

Main Topic	Motion
Subtopic	Periodic Motion
Learning Level	High
Technology Level	High
Activity Type	Student

Description: Use a motion sensor to graph the position, speed, and acceleration of a simple pendulum.

Required Equipment	Workshop Stand, Pendulum, Bolt, String, Pinch Clamp, Motion Sensor, graphing software.
Optional Equipment	

Educational Objectives

- Graph the motion of a simple pendulum.

Concept Overview

Students will dissect the swinging motion of a pendulum. The motion can be described according to the changes in position, speed, and acceleration.

The speed is at its maximum at the bottom of the swing, and zero at the ends. Acceleration is the reverse: zero at the bottom of the swing, and at its maximum at the ends. Capturing the motion with a motion sensor and graphing software will help students describe these trends.

Lab Tips

Assembly:

1. Push the attachment bolt through the top hole of the Workshop Stand.
2. Screw the bolt into the back of the Pendulum, so that the printed side faces out.
3. Use the pinch clamp to support the string, and attach one of the cylindrical bobs to the string. Adjust the pinch clamp to create the desired pendulum length.
4. Grid Board (for selected experiments): Push the attachment bolt through the Grid Board, then through the stand, at a height that accommodates the entire swing of the pendulum. Screw the nut onto the back to fasten.
5. Align the Pendulum Face and Grid Board by using the string as a plumb bob. Face the stand, close one eye, and turn the pieces as needed so that the vertical lines are aligned with the string. Adjust the stand leveling screws if necessary.

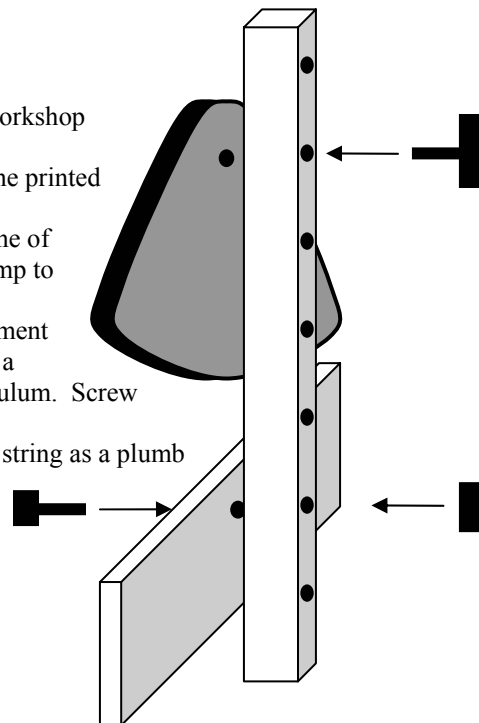

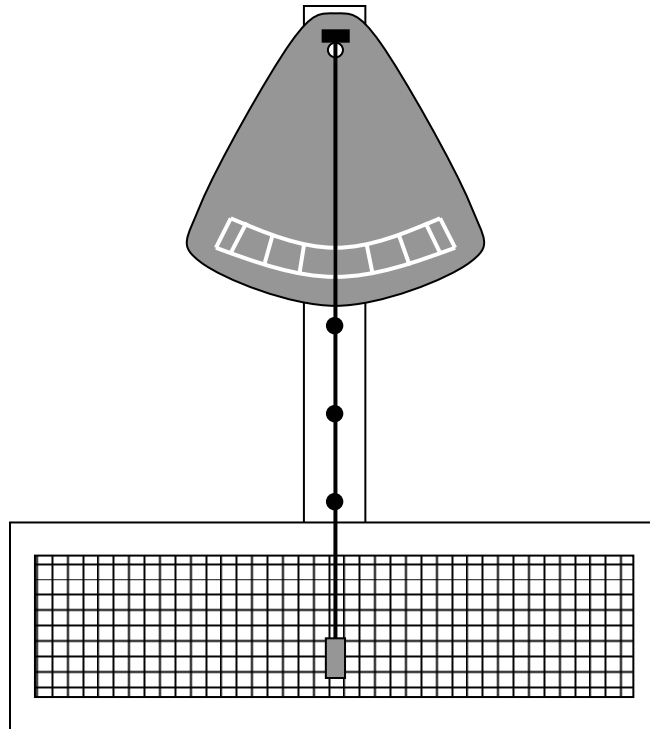

Pendulum: Velocity and Acceleration, Graphing Motion

Objective: To investigate and graph the motion of a swinging pendulum bob.

Materials: Workshop Stand, Pendulum, Bolt, String, Pinch Clamp, Motion Sensor, graphing software.

Procedure:

1. Use the bolt to attach the Pendulum plate to the Workshop Stand at the highest point.
2. Use the Pinch Clamp to create a pendulum that is 60cm long. Hang the aluminum cylinder at the end. (Measure the length from the bottom of the support, where the string will bend, to the bottom of the hanging cylinder.)
3. Stand directly in front of the Pendulum, close one eye, and make sure the "0" mark is aligned with the string as it hangs straight down. Turn the Pendulum plate as necessary.
4. Hold the aluminum bob out so that the string is lines up with the line marked 20. (20° away from the center.) Release the pendulum and observe its motion.
5. If the bob is released from point "A" and swings to point "C" and back, at what point (or between which points) is its:
 - a. Displacement the greatest? _____
 - b. Velocity the greatest? _____
 - c. Acceleration the greatest? _____
 - d. Displacement equal to 0? _____
 - e. Velocity a positive value (away from A)? _____
 - f. Velocity a negative value (back toward A)? _____
 - g. Velocity equal to 0? _____
 - h. Acceleration a positive value (away from A)? _____
 - i. Acceleration a negative value (back toward A)? _____
 - j. Acceleration equal to 0? _____
6. To test your answers, you will use a motion sensor and datalogger to measure the displacement, velocity and acceleration of the bob.
7. Position the motion sensor so that it faces point "A" and is in line with the path of the pendulum bob. Be sure to place it far enough away to accommodate the sensor's minimum distance.
8. Record the motion of the pendulum through at least three cycles, and graph the position, velocity, and acceleration. Print or sketch the graphs and attach them to this page. Label points A, B, and C on the graphs.

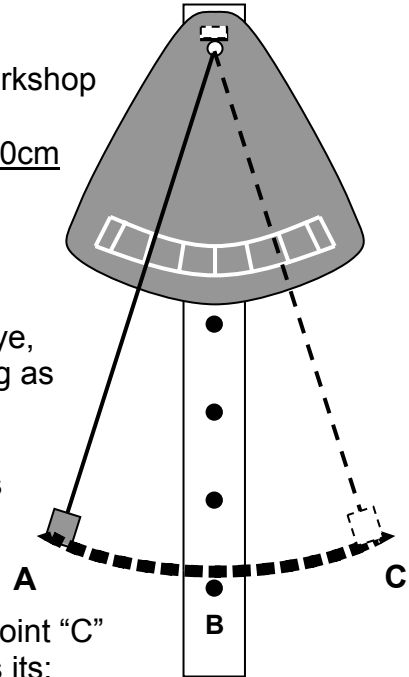

Pendulum Motion

Name: _____

Class: _____

9. Write a paragraph describing the changes in each quantity.

10. Sketch a graph in the space below that represents the total force on the pendulum as it moves through points A, B and C and back. (Hint: Which quantity graphed before most closely follows the force?)