

HEXAGON Pendant

Celebrating the ordered beauty and iconic shape of a beehive honeycomb. Bursts of radiant LED light are contained within the chandelier's hexagonal wood frame, softening its stark silhouette. In multiples, it becomes an immersive ceiling environment, urging onlookers to reflect on its movement and capture of light.

DIMENSIONS + ELEVATION VIEWS

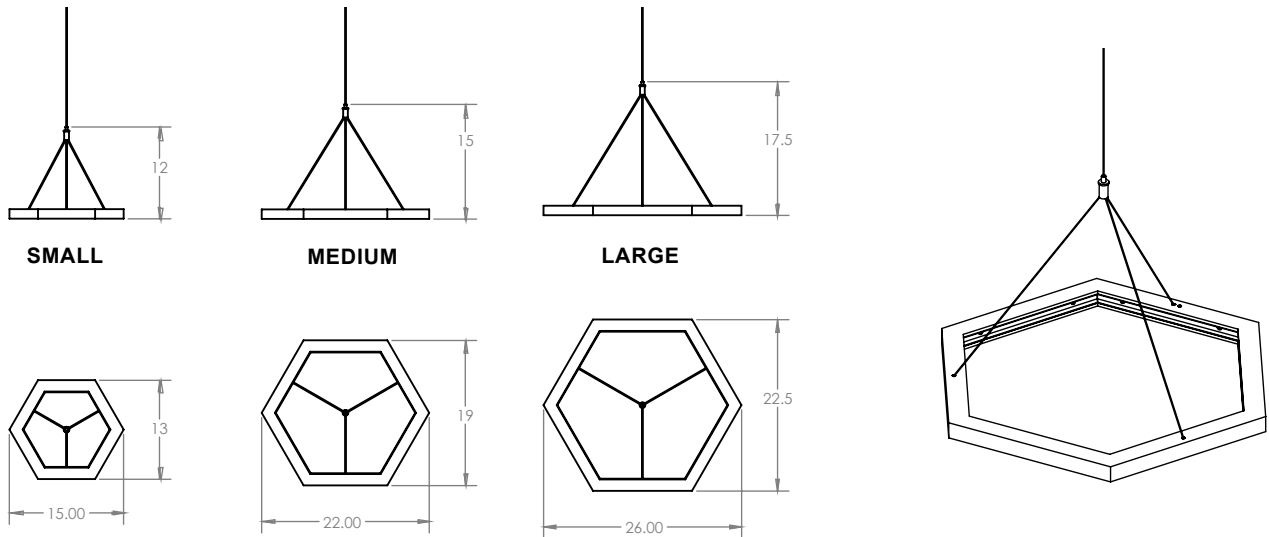

PRODUCT DETAILS



DESIGN
2016

CERTIFICATION



MATERIALS

- Solid Wood
- 24V LED
- Suspension hardware

FINISH

- Hardwax Oil Finish

COLOR TEMP

- 3000K
- *Custom upon request

POWER CONSUMPTION

- Small: 27W
- Medium: 39W
- Large 46W

OUTPUT

- 388 lumens/ft
- Small: 1455 lm,
- Medium: 2134 lm,
- Large: 2522 lm
- Equivalent incandescent 75-100W

DRIVER + DIMMING TYPE

- Magnitude E40R24DC
- Magnitude E75R24DC (large)
24V phase dimmable driver
- Magnitude CVD96R24DC
0-10V dimmable driver
(upon request)

SUSPENSION + CANOPY

- Single point suspension (per fixture)
- Single canopy connection
- 10' cord length power cable
- *Custom lengths upon request

- Canopy supplied with fixture
- Standard canopy finish: ceiling white
- *Custom finish available upon request

FIXTURE WEIGHT

- Small: 2lbs, medium: 3lbs,
Large 4lbs

PRODUCT CODE

- HEXApendant

SIZE

- Small
- Medium
- Large

WOOD

- W. Oak White
- W. Oak Natural
- W. Oak Black
- Walnut

ORDER SPECIFICATIONS

HEXApendant		
MODEL	SIZE	WOOD