

hollis+morris

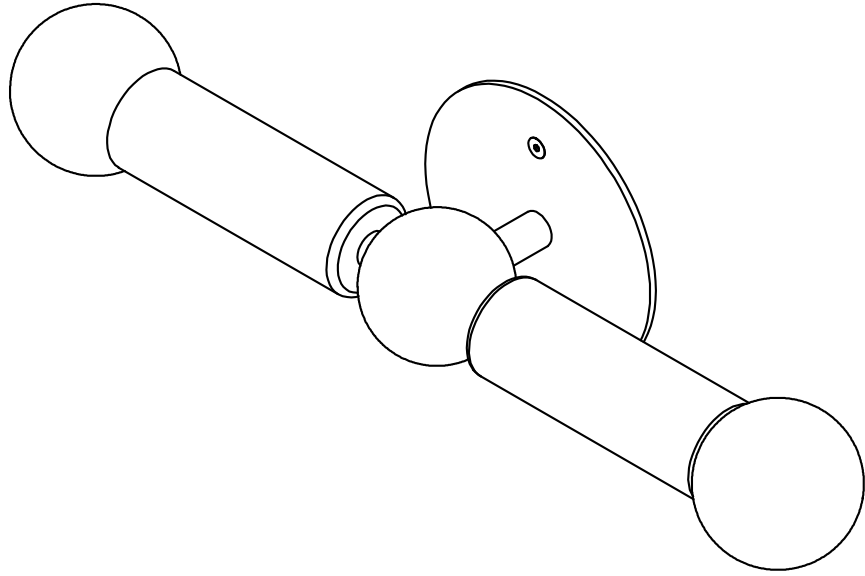

constellation wall

product installation + specifications



constellation wall

product code:
CONSwall

materials:

- + solid wood
- + hand blown glass
- + metal
- + G9 LED light bulb

finish:

- + hardwax oil
- + powder coated or plated steel

input:

- + 120V 50/60 Hz (Canada + US)

output:

- + 9 W
- + 900 lumens
- + 3000K with CRI of 95 or higher

suspension:

- + junction box connection

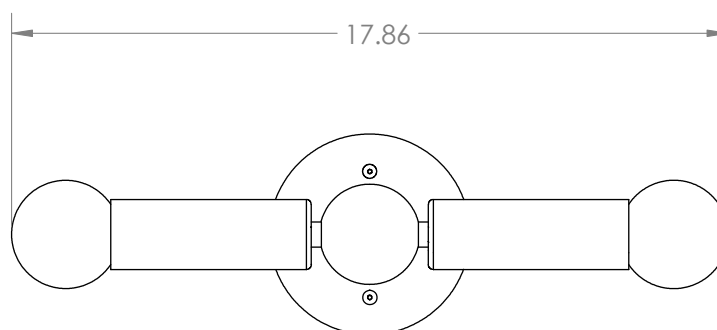
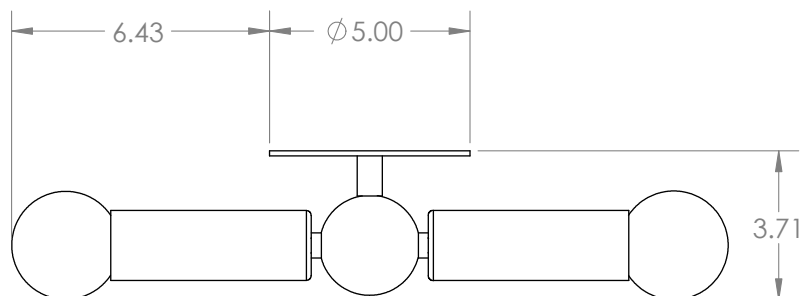

certification:



hardware component list

Component	Quantity	
Constellation Wall	1	
8-32, 1" Flat Head Screw	2	

hardware installation

1. Place the fixture on the wall as intended and mark the fixture mounting point.
2. Have a certified electrician connect the fixture coax to 120 V domestic power.
3. Mount the fixture to a wall using the flat-head 8-32 screws.

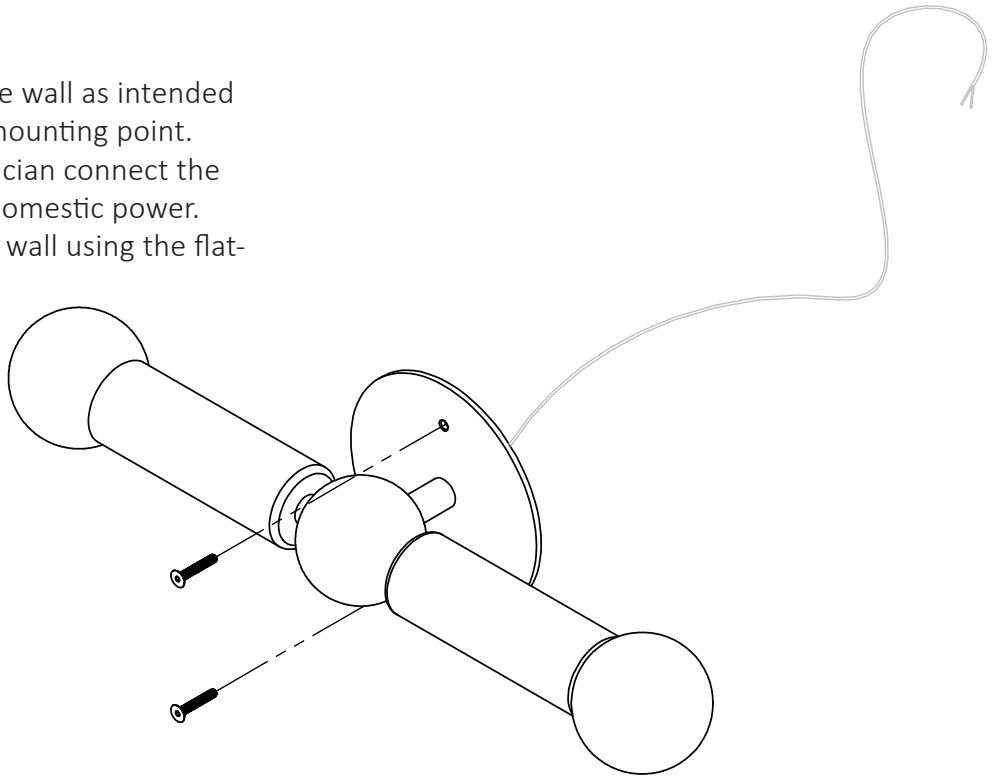

BULB REPLACEMENT

1. Unscrew glass from wood top
2. Remove G9 LED bulb from socket
3. Insert new G9 LED bulb into socket
4. Screw glass onto wood top

