

**hollis+morris**

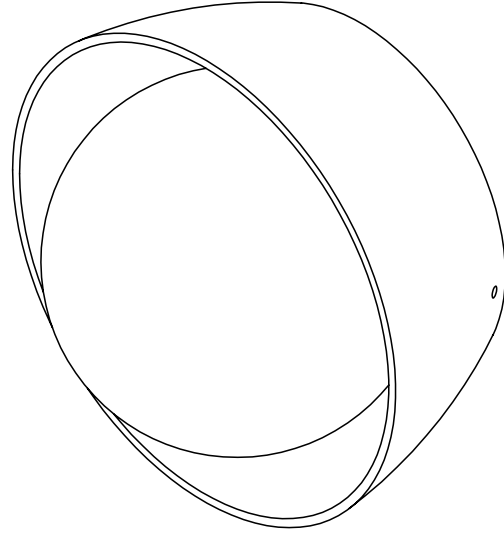

**berm  
sconce**

product installation + specifications



# berm sconce

product code:  
BERMsconce

**materials:**

- + solid wood
- + hand blown glass

**finish:**

- + hardwax oil

**input:**

- + 120V 50/60 Hz (Canada + US)

**output:**

- + 8 W
- + 3000K with CRI of 95 or higher
- + 720 Lms

**mounting:**

- + junction- box connection

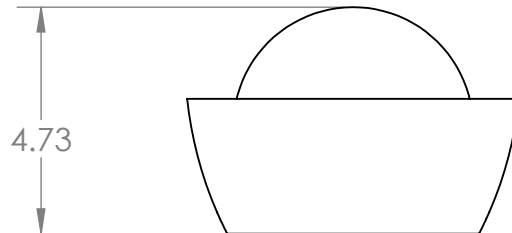
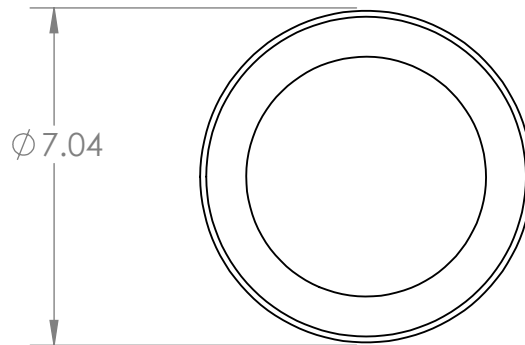

**certification:**



# hardware + installation

1. Feed wires through universal plate adaptor and have a certified electrician connect the fixture to 120V power.
2. Fasten the universal plate adaptor to the junction box using the round head 8-32 screws.
3. Mount the back plate to the universal plate adaptor using the flat head 8-32 screws.

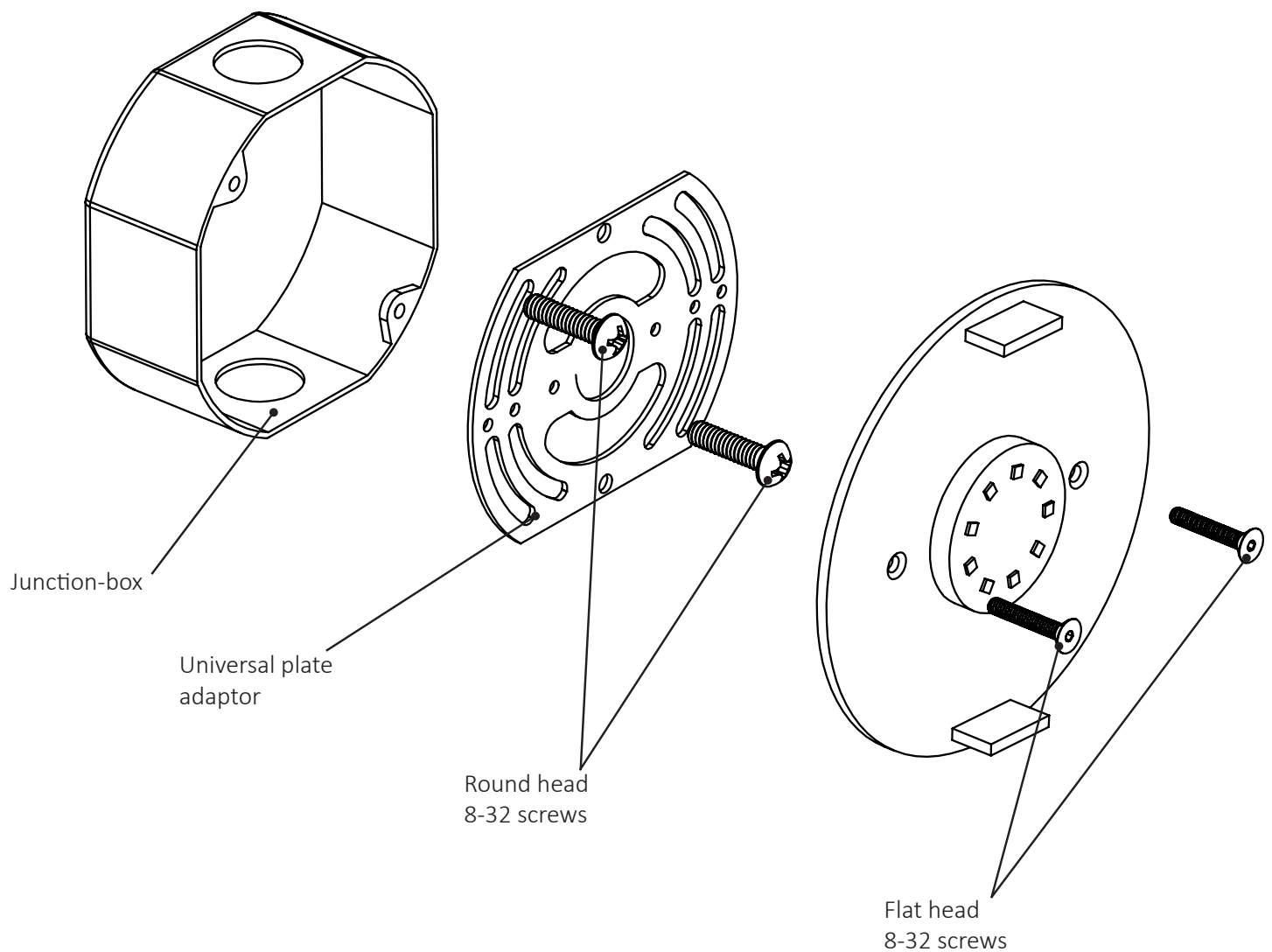

# hardware + installation

4. Place the fixture onto the backplate. The tabs on the backplate should insert into the back of the fixture.
5. Tighten the provided 8-32 set screws to secure the fixture to the backplate.

