



Light Mounting Kit KTM EXC-F, XC-W, XCF-W, Husky FE

LAH.04.11200

Thank you for choosing DENALI

We know you would rather be riding your bike than wrenching on it, so we go the extra mile to make sure our instructions are clear and as easy to understand as possible. If you have any questions, comments, or suggestions don't hesitate to give our gear experts a call at 401.360.2550 or visit WWW.DENALIELECTRONICS.COM

Please Read Before Installing

DENALI products should always be installed by a qualified motorcycle technician. If you are unsure of your ability to properly install a product, please have the product installed by your local motorcycle dealer. DENALI takes no responsibility for damages caused by improper installation. **Caution:** When installing electronics it is extremely important to pay close attention to how wires are routed, especially when mounting products to the front fender, front forks, or fairing of your motorcycle. Always be sure to turn the handlebars fully left, fully right, and fully compress the suspension to ensure the wires will not bind and have enough slack for your motorcycle to operate properly.

Installation Tips

We strongly recommend using medium strength liquid thread locker on all screws, nuts, and bolts. It is also important to ensure that all hardware is tightened to the proper torque specifications as listed in your owner's manual. For included accessory hardware please refer to the default torque specifications provided below. Inspect all hardware after the first 30 miles to ensure proper torque specifications are maintained.

Bolt Size	in-lbs	ft-lbs	Nm
M3	10.0 in-lbs	-	1.0 Nm
M4	23.0 in-lbs	-	2.5 Nm
M5	44.5 in-lbs	3.5 ft-lbs	5.0 Nm
M6	78.0 in-lbs	6.5 ft-lbs	9.0 Nm
M8	-	13.5 ft-lbs	18.0 Nm
M10	-	30.0 ft-lbs	41.0 Nm
M12	-	52.0 ft-lbs	71.0 Nm

Hardware Sizing Guide

Not sure what size bolt you have? Use this ruler to measure screws, bolts, spacers, etc. Remember, the length of a screw or bolt is measured from the start of the "mounting surface" to the end of the screw, so only include the screw head when measuring countersunk screws.

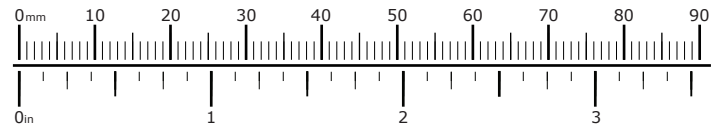

What's In The Box?

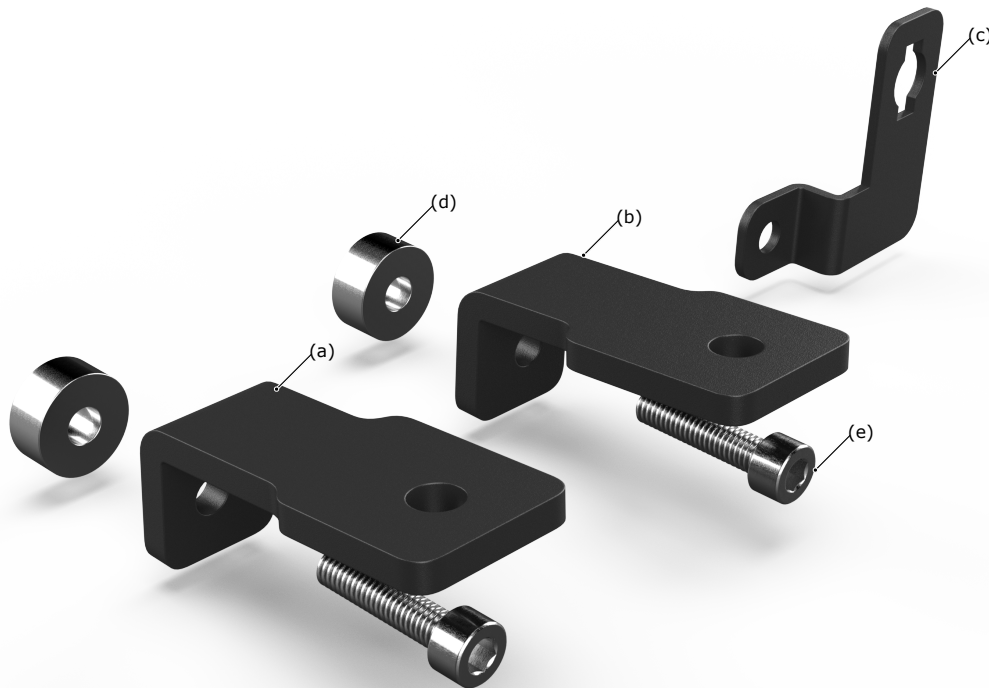

Kit Contents

- (a) RHS Mounting Bracket.....(LAH.53.11200-02).....Qty 1
- (b) LHS Mounting Bracket.....(LAH.53.11200-03).....Qty 1
- (c) Horn Relocation Bracket.....(LAH.04.11200-01).....Qty 1

- (d) Spacer- OD: 18mm ID: 6.5mm L: 8mm.....Qty 2
- (e) M6x25 DIN 912 Socket Head Screw.....Qty 2

Tools: 5mm Hex Drive, T30 Torx Drive.....

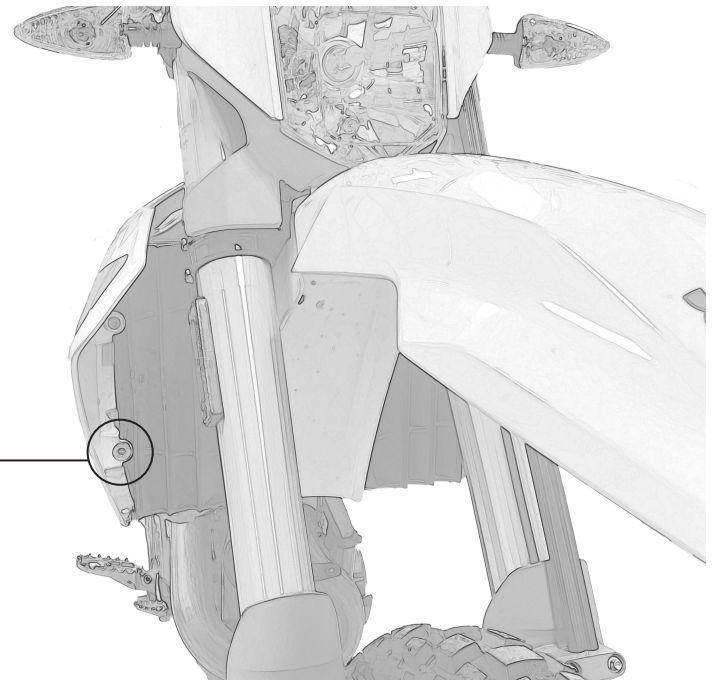
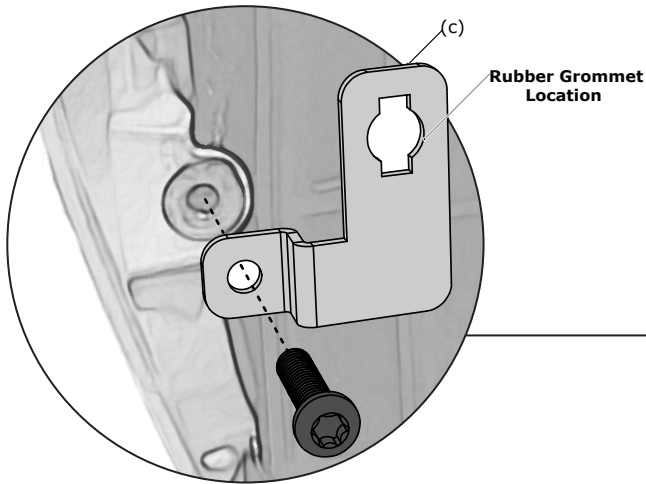

1.1 - Installing The Horn Bracket

Step One: On the lower right hand side of radiator guard locate the factory horn. Disconnect the horn harness and remove the horn and bracket from the bike.

Step Two: Separate the horn from the factory bracket, then remove the rubber and metal bushing from the factory horn brackets mounting hole and re-install it into the keyed hole on the new horn bracket (c).

Step Three: Install the horn onto the new Horn Bracket (c) and mount it to the bike using the same mounting location and factory screw.

1.2 - Installing The Horn Bracket

Step Four: Plug the horn harness back in.

Note: The new mounting location will position the horn down and to the right of its original spot which will create more space for the light mount.

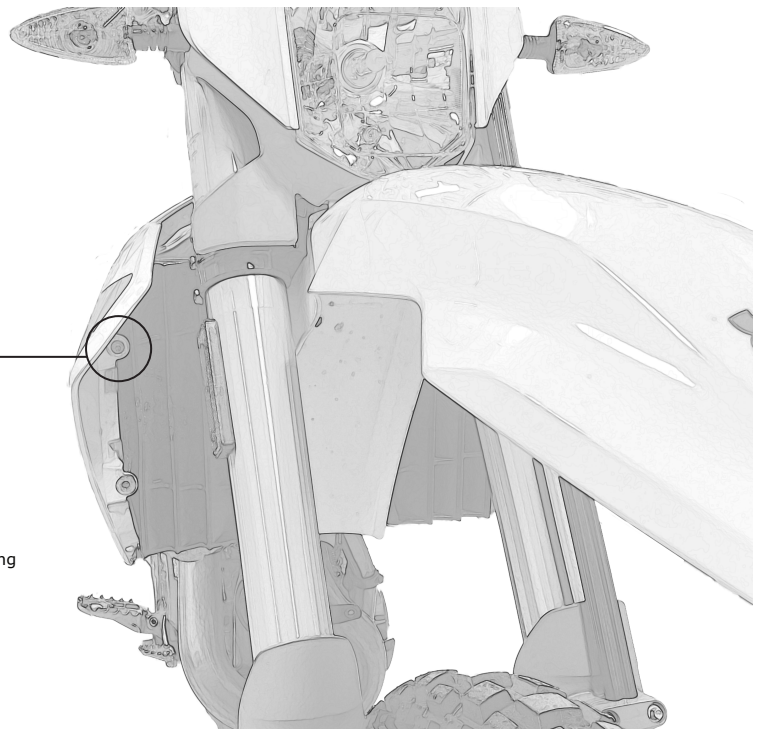
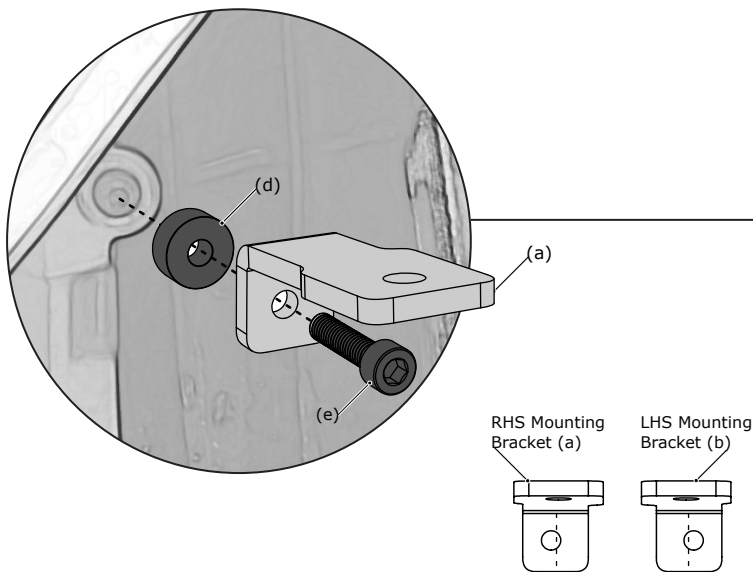

1.3 - Installing The Light Mount

Note: To Identify which side each light mount bracket goes on look at the reference above. The bottom mounting hole on the bracket is offset towards the outside of the bike.

Step Five: Pick a side to start with then locate the mounting point on the top of the radiator guard and remove the factory bolt.

Step Six: Identify the correct light mount bracket (a or b) for the side you chose to start with. Mount the bracket in place with the provided spacer (d) behind it and secure it with the M6x25mm Socket Head Screw (e).

1.4 - Connecting The Light Pods

Step Seven: Repeat the steps on the other side to mount the remaining bracket. Once both Light mount brackets (a,b) are leveled and properly tightened the Denali LED Light Pods can be hung. The Denali DM or D2 Light Pods will mount inverted with the hinge secured to the bottom side of the light brackets mounting shelf.