



HMT.22.10100
Ducati Scrambler
SoundBomb Horn Mount

Thank you for choosing DENALI

We know you would rather be riding your bike than wrenching on it, so we go the extra mile to make sure our instructions are clear and as easy to understand as possible. If you have any questions, comments, or suggestions don't hesitate to give our gear experts a call at 401.360.2550 or visit WWW.DENALIELECTRONICS.COM

Please Read Before Installing

DENALI products should always be installed by a qualified motorcycle technician. If you are unsure of your ability to properly install a product, please have the product installed by your local motorcycle dealer. DENALI takes no responsibility for damages caused by improper installation. **Caution:** When installing electronics it is extremely important to pay close attention to how wires are routed, especially when mounting products to the front fender, front forks, or fairing of your motorcycle. Always be sure to turn the handlebars fully left, fully right, and fully compress the suspension to ensure the wires will not bind and have enough slack for your motorcycle to operate properly.

Installation Tips

We strongly recommend using medium strength liquid thread locker on all screws, nuts, and bolts. It is also important to ensure that all hardware is tightened to the proper torque specifications as listed in your owner's manual. For included accessory hardware please refer to the default torque specifications provided below. Inspect all hardware after the first 30 miles to ensure proper torque specifications are maintained.

Bolt Size	in-lbs	ft-lbs	Nm
M3	10.0 in-lbs	-	1.0 Nm
M4	23.0 in-lbs	-	2.5 Nm
M5	44.5 in-lbs	3.5 ft-lbs	5.0 Nm
M6	78.0 in-lbs	6.5 ft-lbs	9.0 Nm
M8	-	13.5 ft-lbs	18.0 Nm
M10	-	30.0 ft-lbs	41.0 Nm
M12	-	52.0 ft-lbs	71.0 Nm

Hardware Sizing Guide

Not sure what size bolt you have? Use this ruler to measure screws, bolts, spacers, etc. Remember, the length of a screw or bolt is measured from the start of the "mounting surface" to the end of the screw, so only include the screw head when measuring countersunk screws.

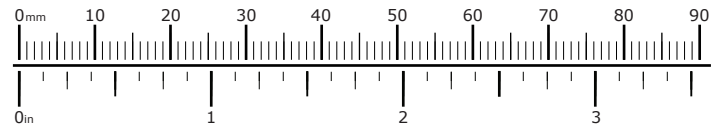

What's In The Box?



Kit Contents

- (a) Horn Mounting Bracket.....(HMT.22.002).....Qty 1
- (b) M6 x 35 DIN 912.....Qty 2
- (c) M6 Washer DIN 125.....Qty 2
- (d) Spacer L:14.288mmQty 2

Tools Required: 5mm Allen Key, 13mm open end wrench

1. Installing The Bracket

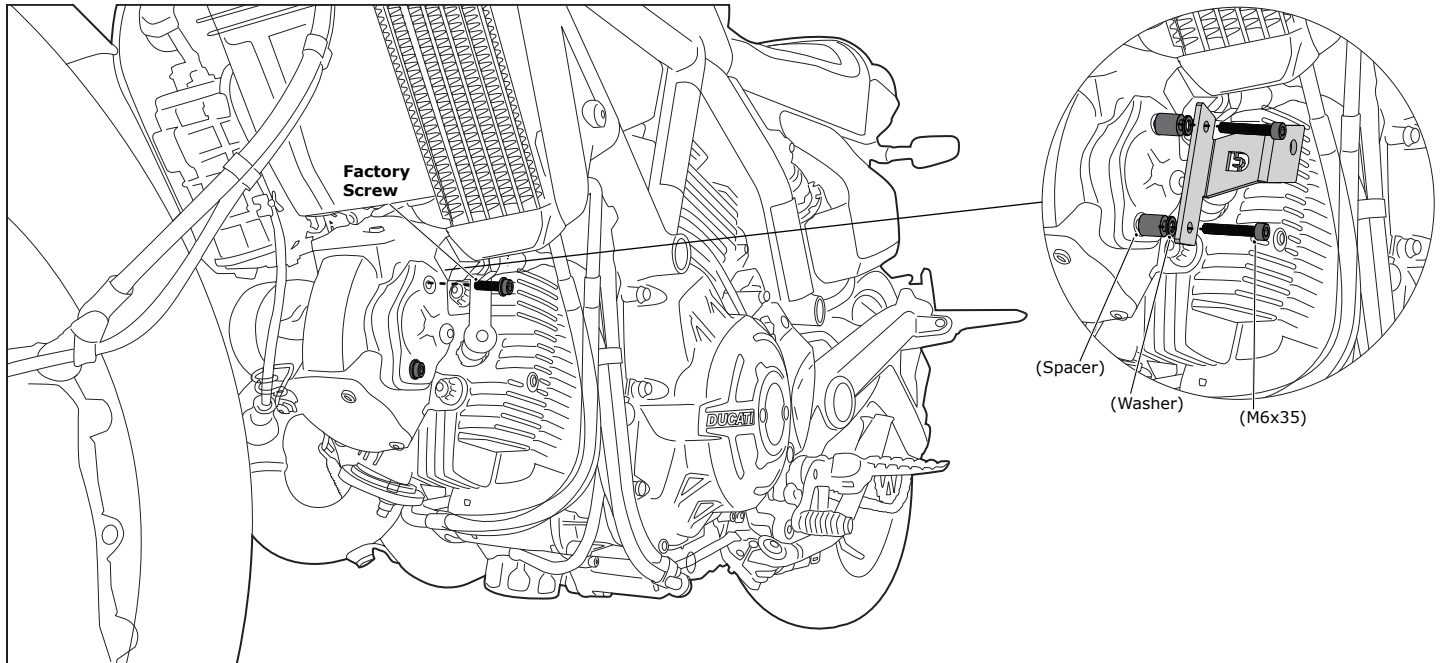

1.1 - Installing the Bracket

Step One: Locate the mounting location for your bracket and remove the top factory screw.

Step Two: Line up the spacer (d), washer (c) and top of the bracket (a) with the mounting hole and hand tighten with the M6x35mm screw (b). Rotate the bracket clockwise to gain access to the bottom factory screw and remove it. Rotate the bracket back and secure the spacer, washer, bracket and M6 screw into the bottom mounting point and properly tighten both using a 5mm Allen wrench.

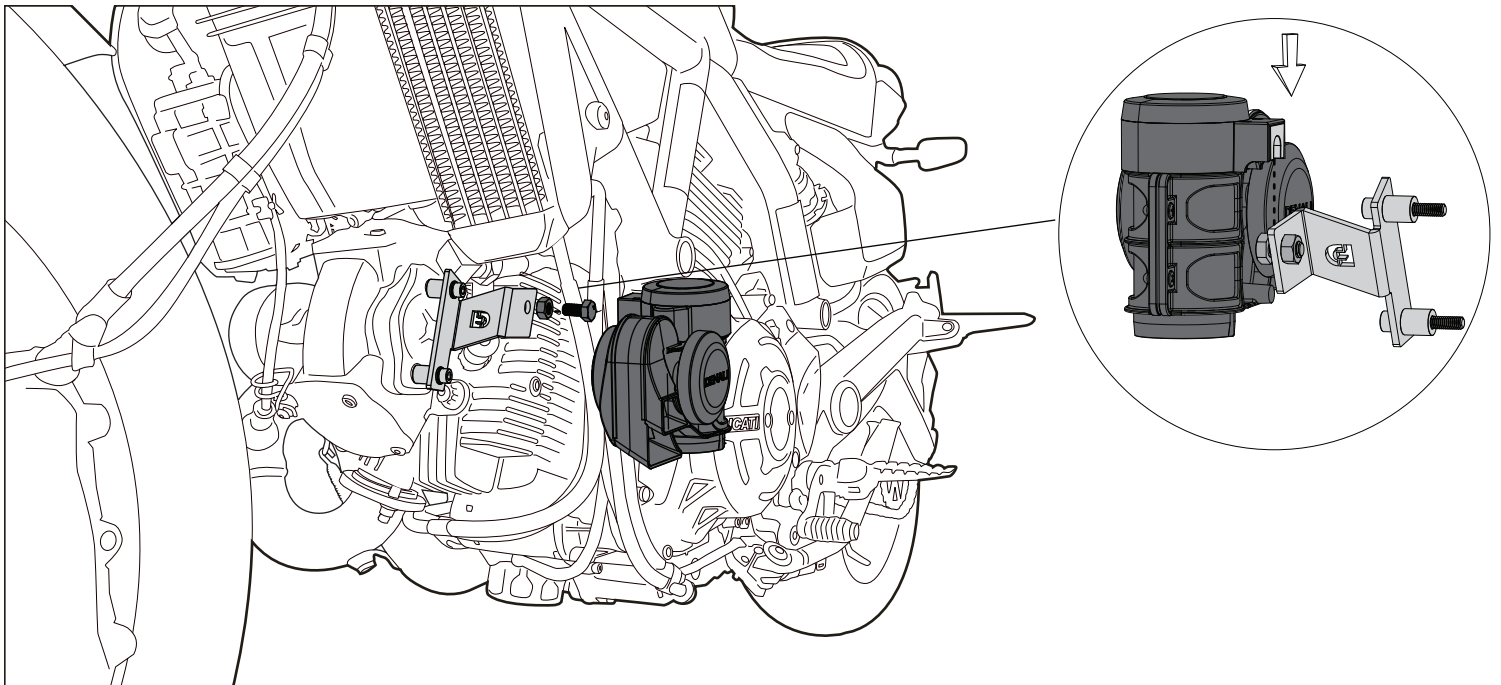

1.2 - Mounting the Horn

Step One: Use the hardware supplied with the SoundBomb Horn to attach it to the bracket. Use a 13mm wrench to tighten the nut on the back side of the mount.

Note: Before fully tightening the horn, you can make small adjustments by slightly rotating the horn to better match the profile of your bike. The horn should not exceed 10 degrees of tilt and should be as close to 90 degrees upright as possible. When happy with the position make sure to fully tighten the horn.