



Crash Bar Light Mounting Brackets

Ducati DesertX
LAH.22.10302

Thank you for choosing DENALI

We know you would rather be riding your bike than wrenching on it, so we go the extra mile to make sure our instructions are clear and as easy to understand as possible. If you have any questions, comments, or suggestions don't hesitate to give our gear experts a call at 401.360.2550 or visit WWW.DENALIELECTRONICS.COM

Please Read Before Installing

DENALI products should always be installed by a qualified motorcycle technician. If you are unsure of your ability to properly install a product, please have the product installed by your local motorcycle dealer. DENALI takes no responsibility for damages caused by improper installation. **Caution:** When installing electronics it is extremely important to pay close attention to how wires are routed, especially when mounting products to the front fender, front forks, or fairing of your motorcycle. Always be sure to turn the handlebars fully left, fully right, and fully compress the suspension to ensure the wires will not bind and have enough slack for your motorcycle to operate properly.

Installation Tips

We strongly recommend using medium strength liquid thread locker on all screws, nuts, and bolts. It is also important to ensure that all hardware is tightened to the proper torque specifications as listed in your owner's manual. For included accessory hardware please refer to the default torque specifications provided below. Inspect all hardware after the first 30 miles to ensure proper torque specifications are maintained.

Bolt Size	in-lbs	ft-lbs	Nm
M3	10.0 in-lbs	-	1.0 Nm
M4	23.0 in-lbs	-	2.5 Nm
M5	44.5 in-lbs	3.5 ft-lbs	5.0 Nm
M6	78.0 in-lbs	6.5 ft-lbs	9.0 Nm
M8	-	13.5 ft-lbs	18.0 Nm
M10	-	30.0 ft-lbs	41.0 Nm
M12	-	52.0 ft-lbs	71.0 Nm

Hardware Sizing Guide

Not sure what size bolt you have? Use this ruler to measure screws, bolts, spacers, etc. Remember, the length of a screw or bolt is measured from the start of the "mounting surface" to the end of the screw, so only include the screw head when measuring countersunk screws.

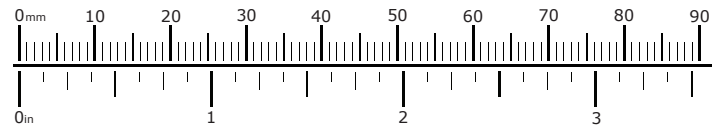

What's In The Box?

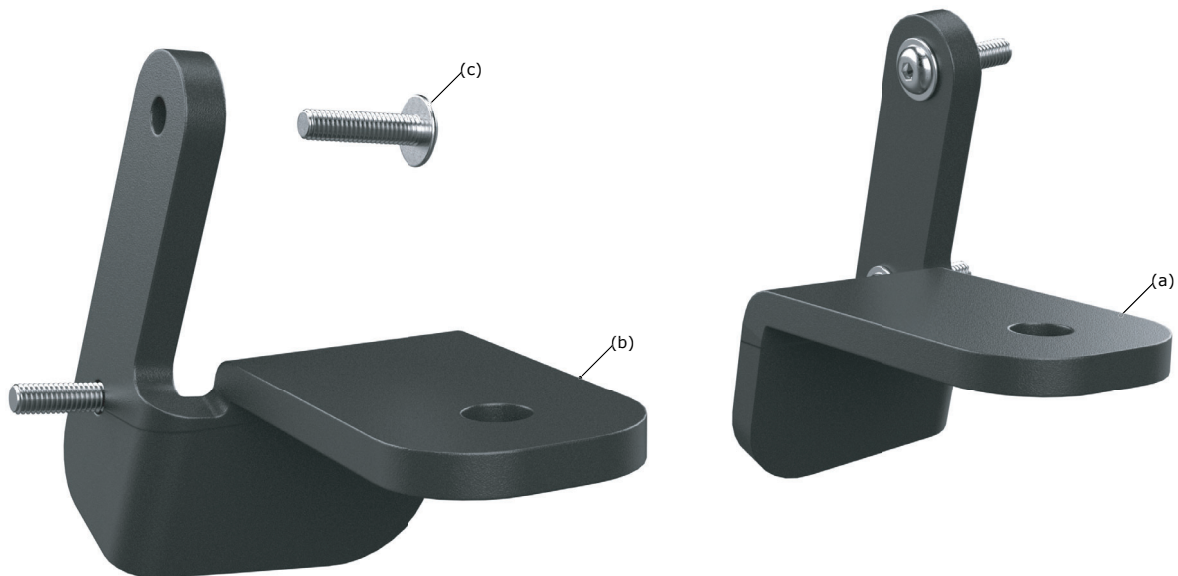

Kit Contents

- (a) Upper Light Mounting Bracket - Left (LAH.22.10302-01).....Qty 1
- (b) Upper Light Mounting Bracket - Right (LAH.22.10302-02).....Qty 1
- (c) M5 x 25mm Flanged Button Head Screw.....Qty 4

Tools Required: 3mm Wrench

Note: This bracket set is designed to work with Ducati DesertX "Steel Engine Cover Crash Guards" - 96781851AA

1. Installing The Light Mount

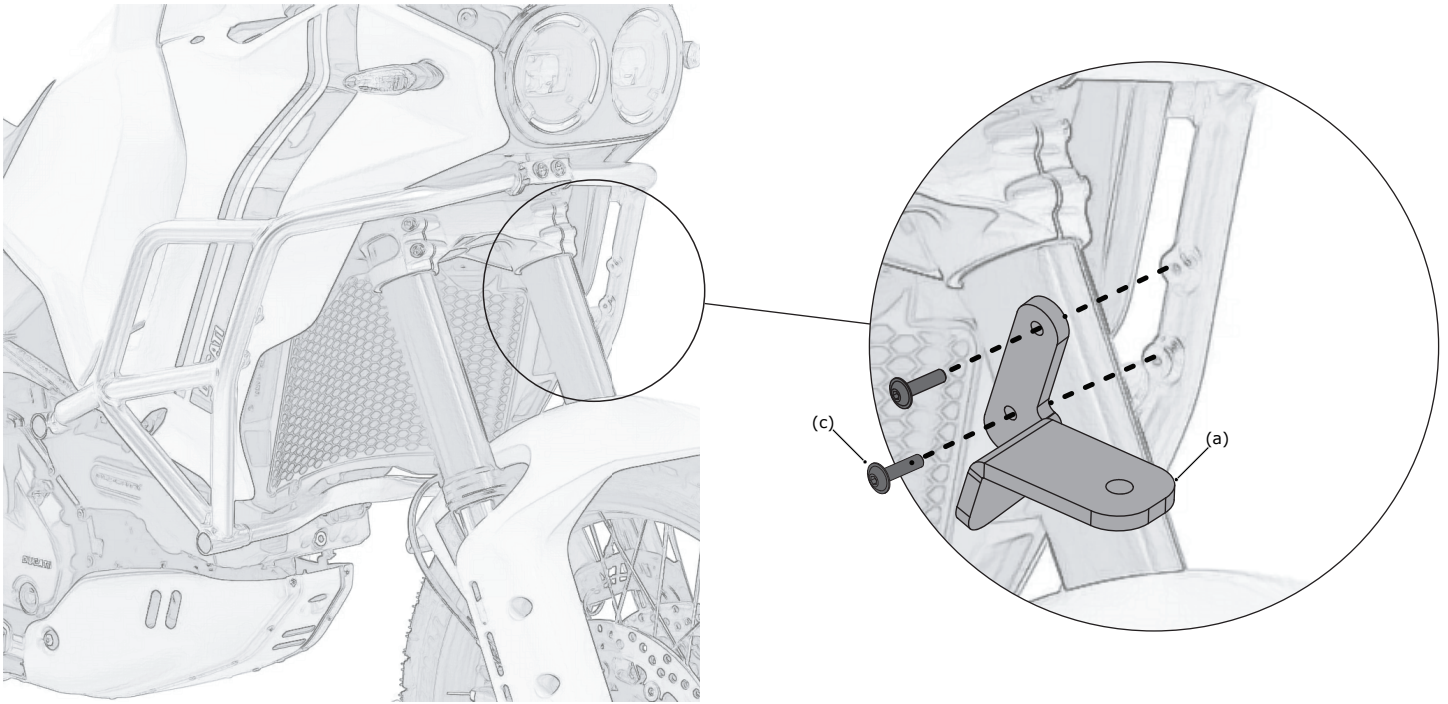

1.1 - Install the Mounts

Step One: Install the Upper Light Mounting Bracket - Left (a) to the Clutch side of the bike with two M5 x 25mm Screws (c). Tighten with a 3mm allen driver.

Step Two: Install the Upper Light Mounting Bracket - Right (b) to the Throttle side of the bike with two M5 x 25mm Screws (c). Tighten with a 3mm allen driver. (Not shown)

Note: Install light pods on top of the bracket shelf, with the light bracket facing downwards, mounting to the top surface of the light mount.

The brackets are designed to keep DENALI LED lights mounted tightly against the crash bars. Optimal installation requires the lights to be positioned towards the bottom of the slotted holes of their swivel brackets.