



LAH.08.10900
Kawasaki KLR 650
Upper Crash Bar Light Mount

Thank you for choosing DENALI

We know you would rather be riding your bike than wrenching on it, so we go the extra mile to make sure our instructions are clear and as easy to understand as possible. If you have any questions, comments, or suggestions don't hesitate to give our gear experts a call at 401.360.2550 or visit WWW.DENALIELECTRONICS.COM

Please Read Before Installing

DENALI products should always be installed by a qualified motorcycle technician. If you are unsure of your ability to properly install a product, please have the product installed by your local motorcycle dealer. DENALI takes no responsibility for damages caused by improper installation. **Caution:** When installing electronics it is extremely important to pay close attention to how wires are routed, especially when mounting products to the front fender, front forks, or fairing of your motorcycle. Always be sure to turn the handlebars fully left, fully right, and fully compress the suspension to ensure the wires will not bind and have enough slack for your motorcycle to operate properly.

Installation Tips

We strongly recommend using medium strength liquid thread locker on all screws, nuts, and bolts. It is also important to ensure that all hardware is tightened to the proper torque specifications as listed in your owner's manual. For included accessory hardware please refer to the default torque specifications provided below. Inspect all hardware after the first 30 miles to ensure proper torque specifications are maintained.

Bolt Size	in-lbs	ft-lbs	Nm
M3	10.0 in-lbs	-	1.0 Nm
M4	23.0 in-lbs	-	2.5 Nm
M5	44.5 in-lbs	3.5 ft-lbs	5.0 Nm
M6	78.0 in-lbs	6.5 ft-lbs	9.0 Nm
M8	-	13.5 ft-lbs	18.0 Nm
M10	-	30.0 ft-lbs	41.0 Nm
M12	-	52.0 ft-lbs	71.0 Nm

Hardware Sizing Guide

Not sure what size bolt you have? Use this ruler to measure screws, bolts, spacers, etc. Remember, the length of a screw or bolt is measured from the start of the "mounting surface" to the end of the screw, so only include the screw head when measuring countersunk screws.

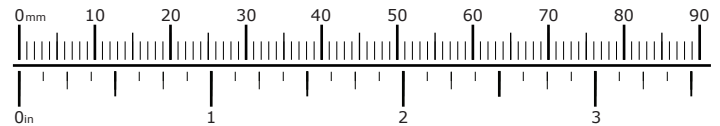

What's In The Box?

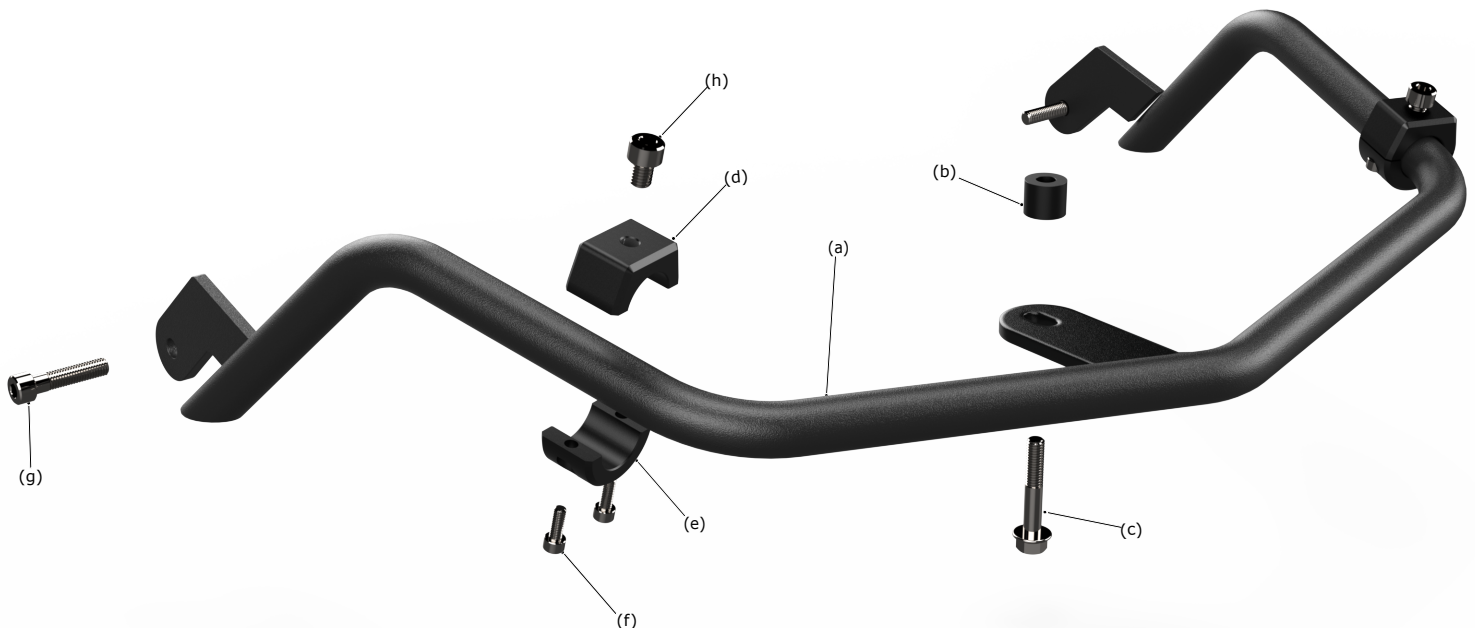

Kit Contents

- (a) Upper Crash Bar.....Qty 1
- (b) M8 Spacer OD:19mm ID:8.4mm Length:15mm.....Qty 1
- (c) M8 x 30mm Flanged Hex Head Screw DIN 6921.....Qty 1
- (d) Crash Bar Clamp Mount Upper.....Qty 2

- (e) Crash Bar Clamp Mount Lower.....Qty 2
- (f) M5 x 14MM Socket Head Screw DIN 912.....Qty 4
- (g) M8 x 40mm Socket Head Screw DIN 912.....Qty 2
- (h) M8 x 10mm Socket Head Screw DIN 912Qty 2

Tools Required: 4mm Hex, 6mm Hex, 12mm Wrench

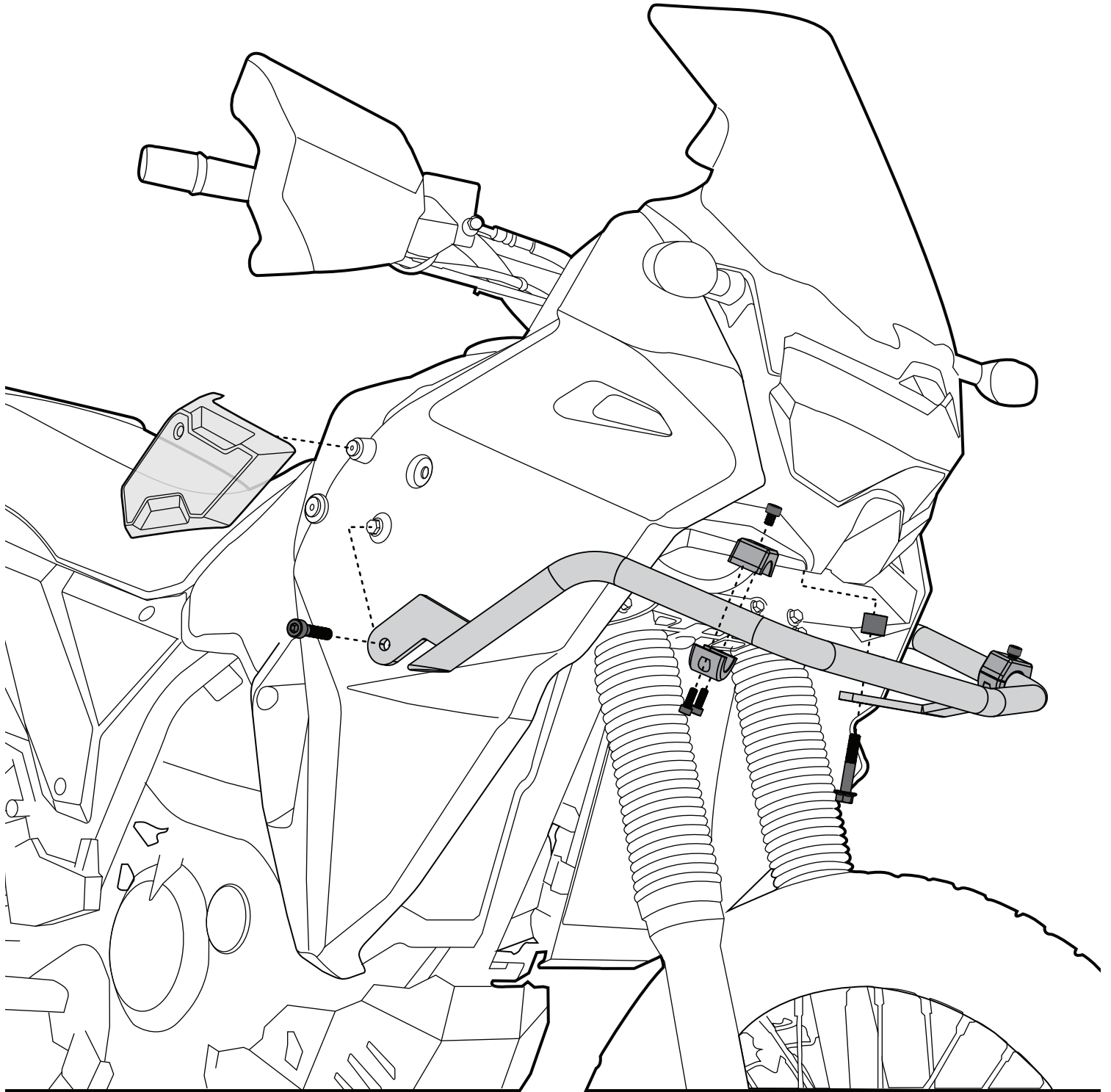

1.1 - Crash Bar Mount Installation

Step One: Remove the front fender and the left & right side covers to gain access to all of the mounting points. After removing the side covers locate the bottom right factory hex head screw and remove it.

Step Two: Align the side mounting brackets on the crash bar mount (a) with the left & right side mounting holes and attach it to the bike using the two M8 x 40mm Socket Head screws (g). Be careful when bringing the mount up to the bike so as to not scratch the paint.

Note: Don't fully tighten the screws yet, leave loose enough to rotate the whole crash bar mount up.

Step Three: Rotate the Crash Bar (a) up and attach the center bracket using the M8 Spacer (b) between the mounting surface and the top of the bracket and secure it in place from below with the M8 x 30mm Flanged Hex head Screw (c).

Step Four: Properly tighten all mounting screws and reattach both side covers and the front fender.

Step Five: Choose the mounting location for your Denali LED Light Pods and assemble the Crash Bar Clamp Mount components (d,e,f,h). When installing the clamp mount make sure they end up parallel with the ground and symmetrical with each other.